

Pilote ID

France Advanced inconnu-libre 2

Vol N°

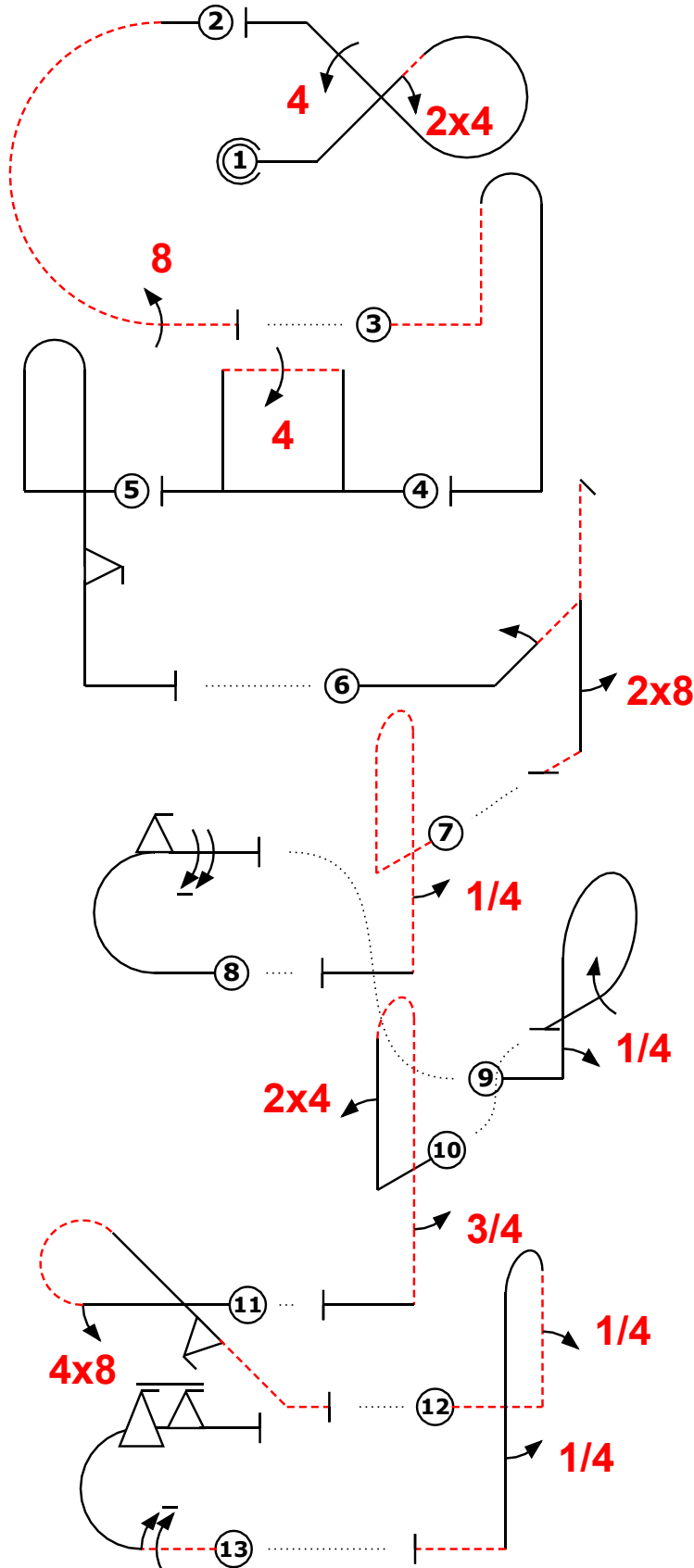

Avion			
Fig	Aresti	K	
1 G	7.3.2.1	14	34
	9.4.2.2	7	
	9.4.2.4	13	
2 I	7.2.1.3	8	23
	9.8.3.4	15	
3 Add.	8.4.4.2	14	8
4 D	7.4.3.1	14	25
	9.4.3.4	11	
5 E	8.4.1.1	13	24
	9.9.5.2	11	
6 H	5.3.2.3	25	34
	9.1.2.2	6	
	9.8.5.1	3	
7 Add.	8.4.2.2	17	8
	9.1.5.1	2	
8 A	7.2.2.1	6	29
	9.9.3.2	11	
	9.1.3.8	12	
9 B	8.6.1.1	11	25
	9.1.1.1	6	
	9.1.3.4	8	
10 J	8.4.3.1	15	30
	9.4.1.2	9	
	9.1.5.3	6	
11 F	8.5.8.1	14	32
	9.8.3.2	7	
	9.9.4.2	11	
12 Add.	8.4.3.2	16	8
	9.1.1.1	6	
	9.1.5.1	2	
13 C	7.2.4.2	6	30
	9.1.3.6	10	
	9.9.3.6	14	
<b>Total K = 310</b>			

Mario Pilote  
Avion

Pilote ID

France Advanced inconnu-libre 2

Vol N°

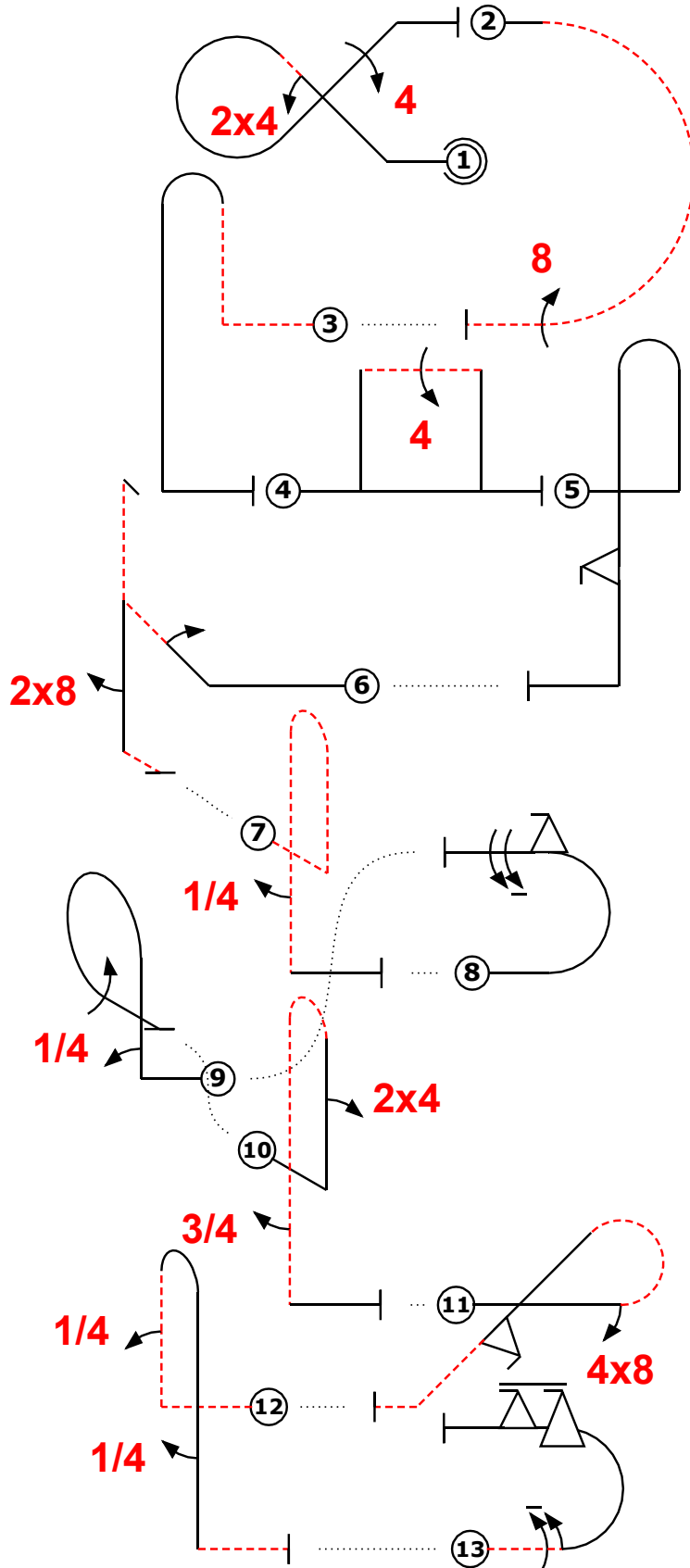

Avion			
Fig	Aresti	K	
1 G	7.3.2.1	14	34
	9.4.2.2	7	
	9.4.2.4	13	
2 I	7.2.1.3	8	23
	9.8.3.4	15	
3 Add.	8.4.4.2	14	8
4 D	7.4.3.1	14	25
	9.4.3.4	11	
5 E	8.4.1.1	13	24
	9.9.5.2	11	
6 H	5.3.2.3	25	34
	9.1.2.2	6	
	9.8.5.1	3	
7 Add.	8.4.2.2	17	8
	9.1.5.1	2	
8 A	7.2.2.1	6	29
	9.9.3.2	11	
	9.1.3.8	12	
9 B	8.6.1.1	11	25
	9.1.1.1	6	
	9.1.3.4	8	
10 J	8.4.3.1	15	30
	9.4.1.2	9	
	9.1.5.3	6	
11 F	8.5.8.1	14	32
	9.8.3.2	7	
	9.9.4.2	11	
12 Add.	8.4.3.2	16	8
	9.1.1.1	6	
	9.1.5.1	2	
13 C	7.2.4.2	6	30
	9.1.3.6	10	
	9.9.3.6	14	
<b>Total K = 310</b>			

Mario Pilote  
Avion

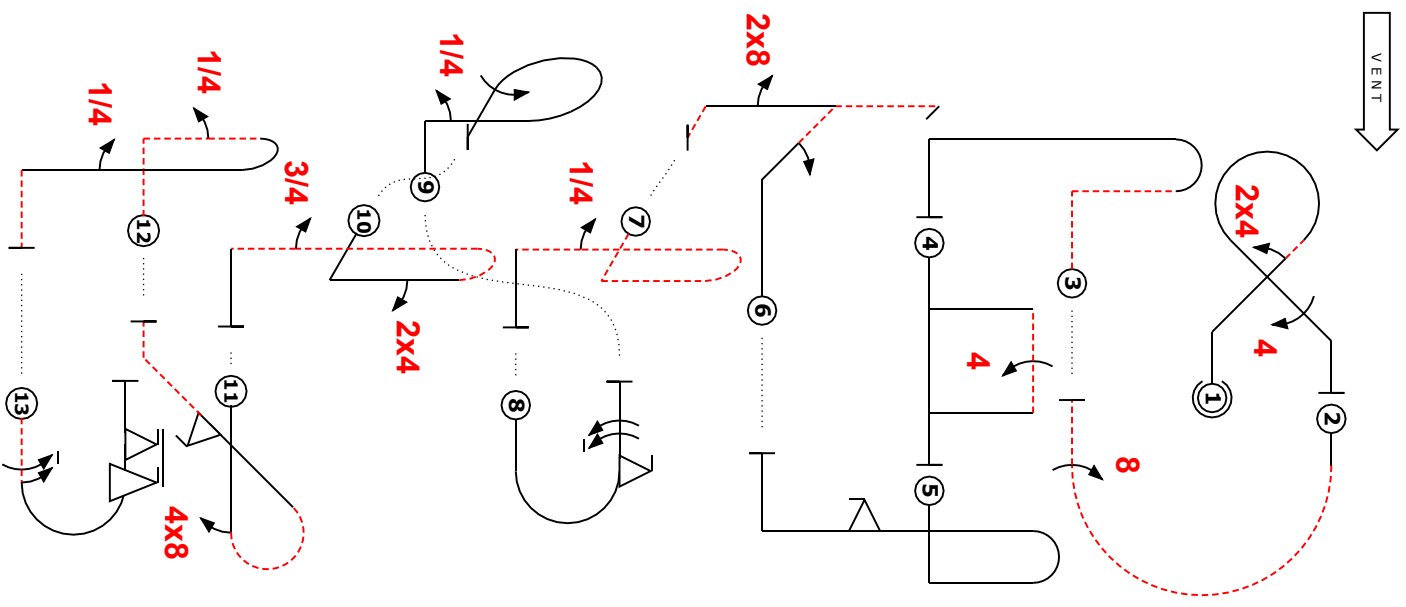
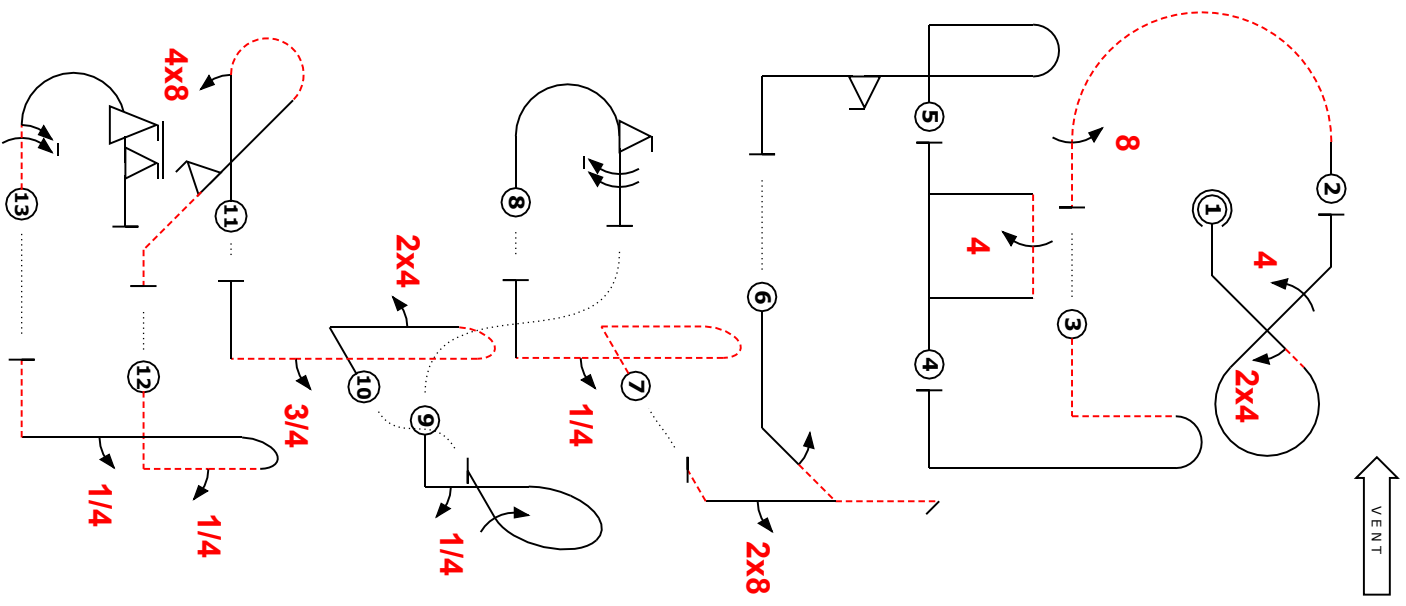



Proposition B		Form B
Pilote ID	CIVA Advanced Programme3	
		Vol N°

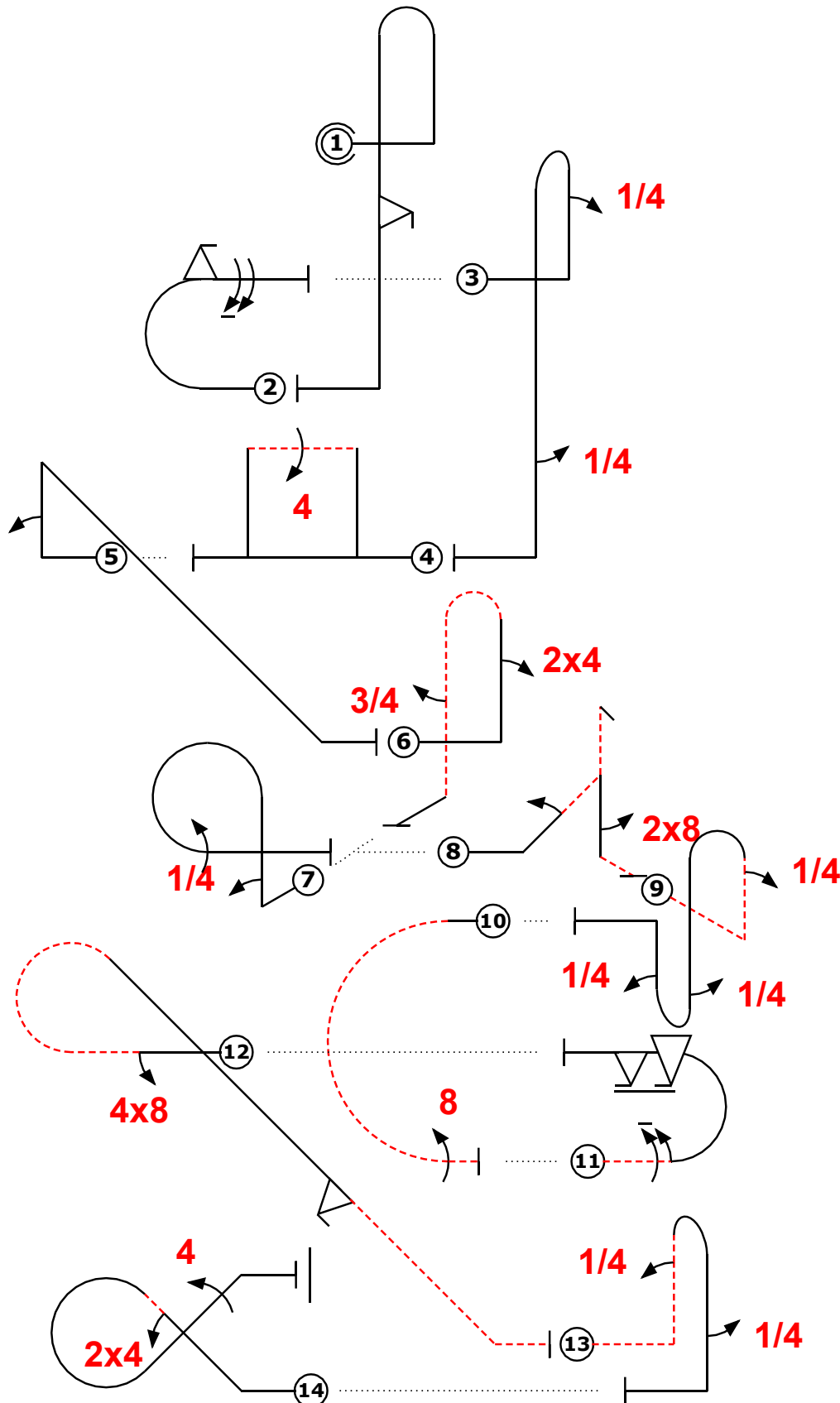

Avion			
Fig	Aresti	K	
1	8.4.1.1	13	24
	9.9.5.2	11	
2 A	7.2.2.1	6	29
	9.9.3.2	11	
	9.1.3.8	12	
3 Add.	8.4.1.1	13	6
	9.1.1.1	6	
	9.1.5.1	2	
4 D	7.4.3.1	14	25
	9.4.3.4	11	
5 Add.	1.2.6.1	14	6
	9.1.1.2	8	
6 J	8.4.3.1	15	30
	9.4.1.2	9	
	9.1.5.3	6	
7 B	8.6.1.1	11	25
	9.1.1.1	6	
	9.1.3.4	8	
8 H	5.3.2.3	25	34
	9.1.2.2	6	
	9.8.5.1	3	
9 Add.	8.8.7.2	21	6
	9.1.1.1	6	
	9.1.5.1	2	
	9.1.1.1	6	
10 I	7.2.1.3	8	23
	9.8.3.4	15	
11 C	7.2.4.2	6	30
	9.1.3.6	10	
	9.9.3.6	14	
12 F	8.5.8.1	14	32
	9.8.3.2	7	
	9.9.4.2	11	
13 Add.	8.4.4.2	14	6
	9.1.1.1	6	
	9.1.5.1	2	
14 G	7.3.2.1	14	34
	9.4.2.2	7	
	9.4.2.4	13	
<b>Total K = 310</b>			

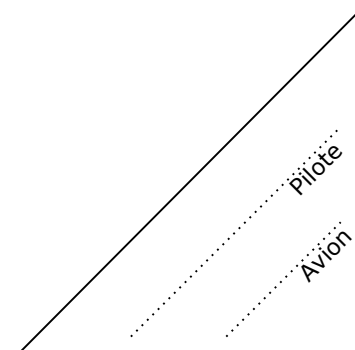



Proposition B		Form C
Pilote ID	CIVA Advanced Programme3	
		Vol N°

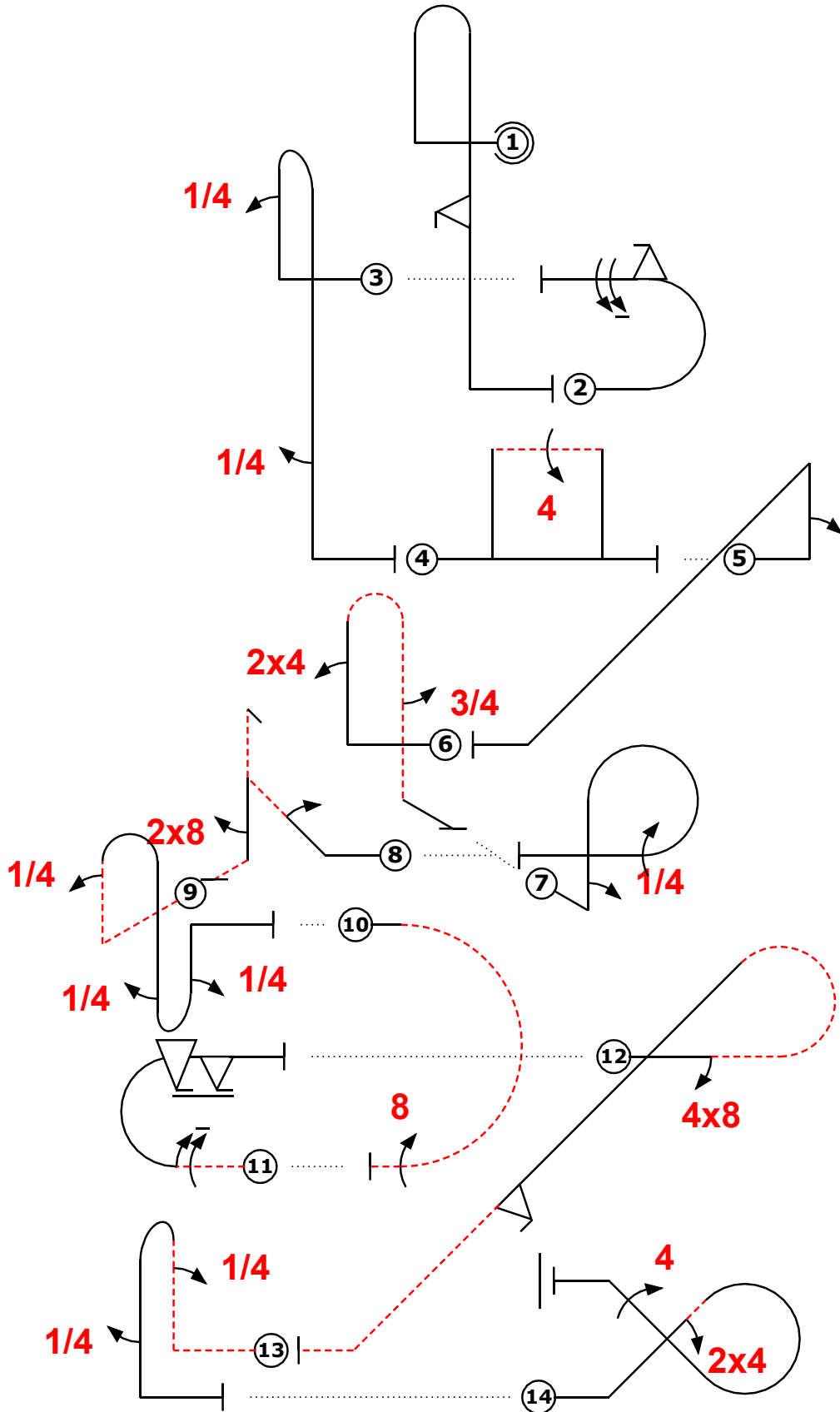

Avion			
Fig	Aresti	K	
1	8.4.1.1	13	24
E	9.9.5.2	11	
2	7.2.2.1	6	29
A	9.9.3.2	11	
	9.1.3.8	12	
3	8.4.1.1	13	6
Add.	9.1.1.1	6	
	9.1.5.1	2	
4	7.4.3.1	14	25
D	9.4.3.4	11	
5	1.2.6.1	14	6
Add.	9.1.1.2	8	
6	8.4.3.1	15	30
J	9.4.1.2	9	
	9.1.5.3	6	
7	8.6.1.1	11	25
B	9.1.1.1	6	
	9.1.3.4	8	
8	5.3.2.3	25	34
H	9.1.2.2	6	
	9.8.5.1	3	
9	8.8.7.2	21	6
Add.	9.1.1.1	6	
	9.1.5.1	2	
	9.1.1.1	6	
10	7.2.1.3	8	23
I	9.8.3.4	15	
11	7.2.4.2	6	30
C	9.1.3.6	10	
	9.9.3.6	14	
12	8.5.8.1	14	32
F	9.8.3.2	7	
	9.9.4.2	11	
13	8.4.4.2	14	6
Add.	9.1.1.1	6	
	9.1.5.1	2	
14	7.3.2.1	14	34
G	9.4.2.2	7	
	9.4.2.4	13	
<b>Total K = 310</b>			

/ Pilote  
 / / Avion

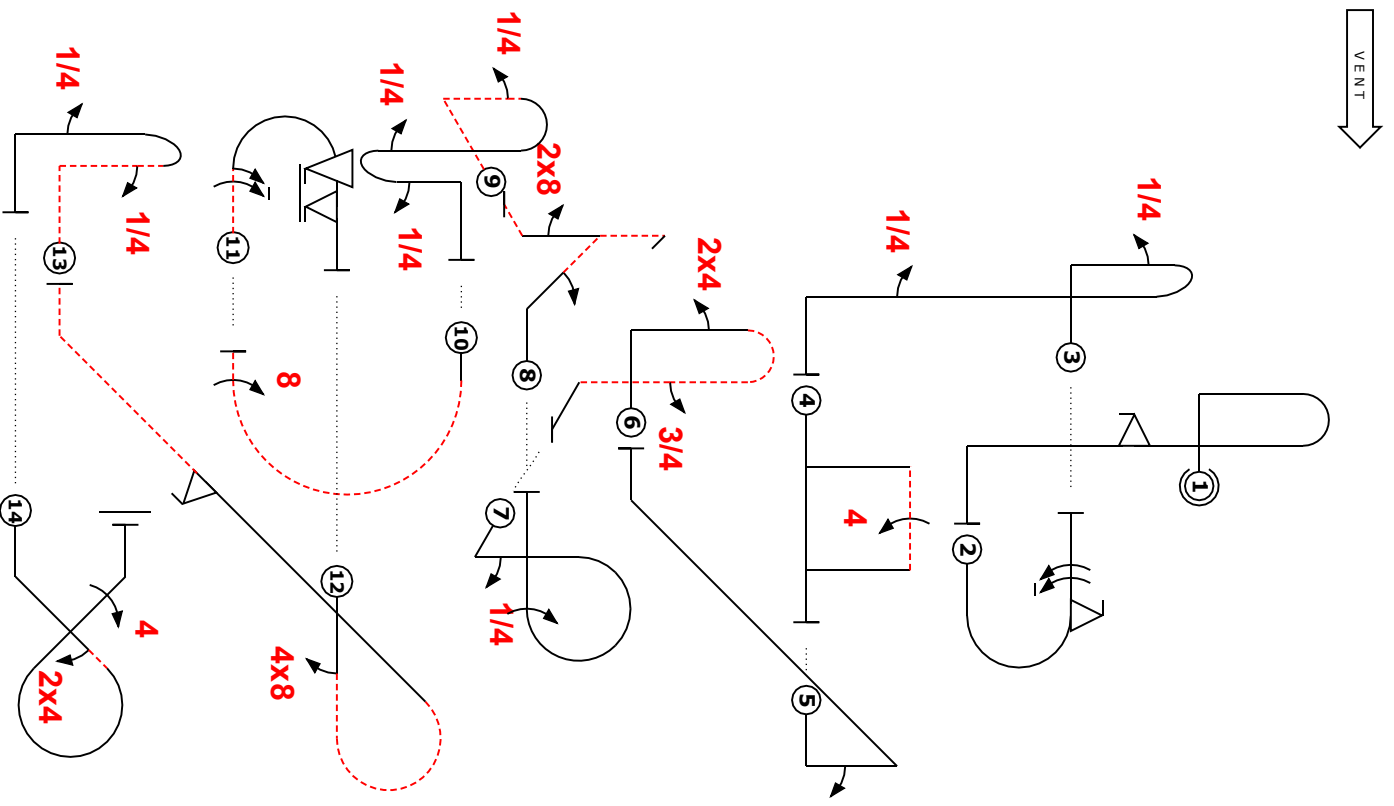
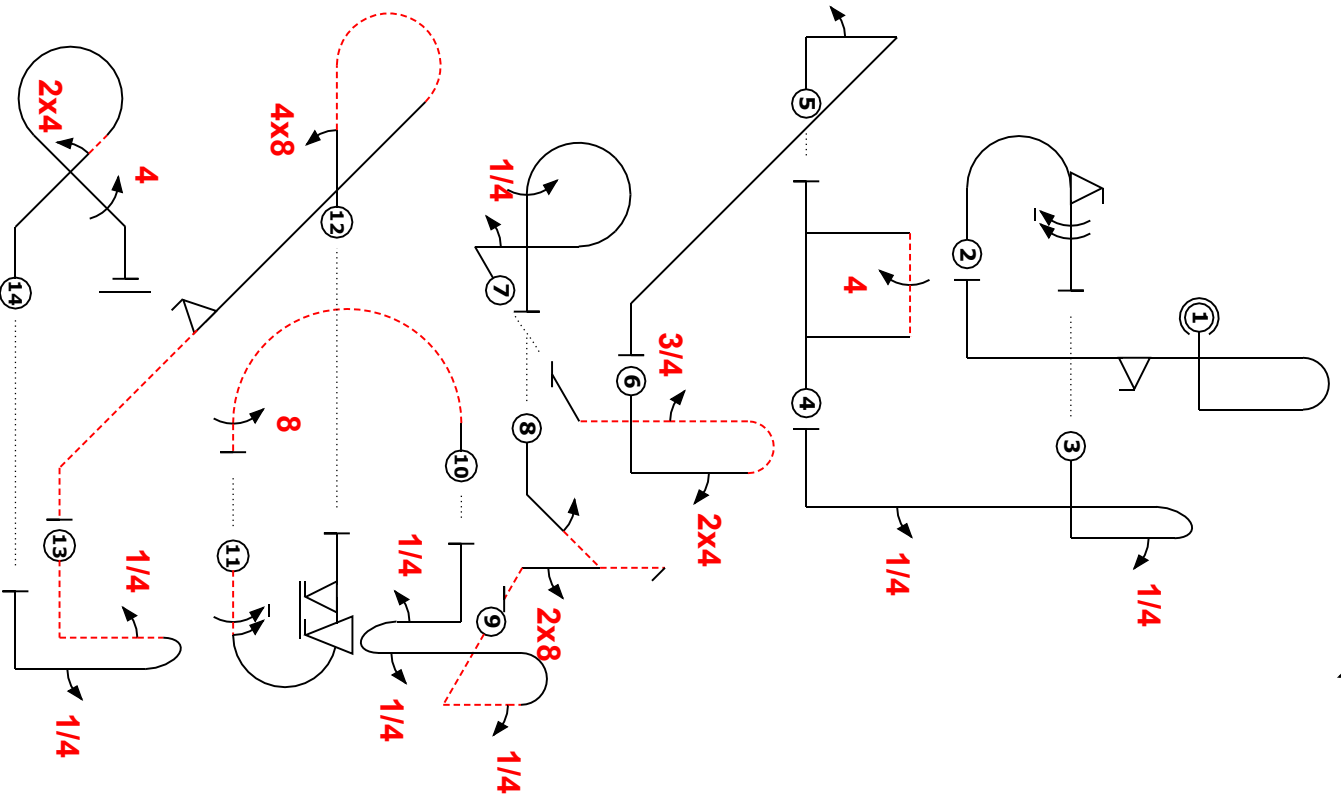

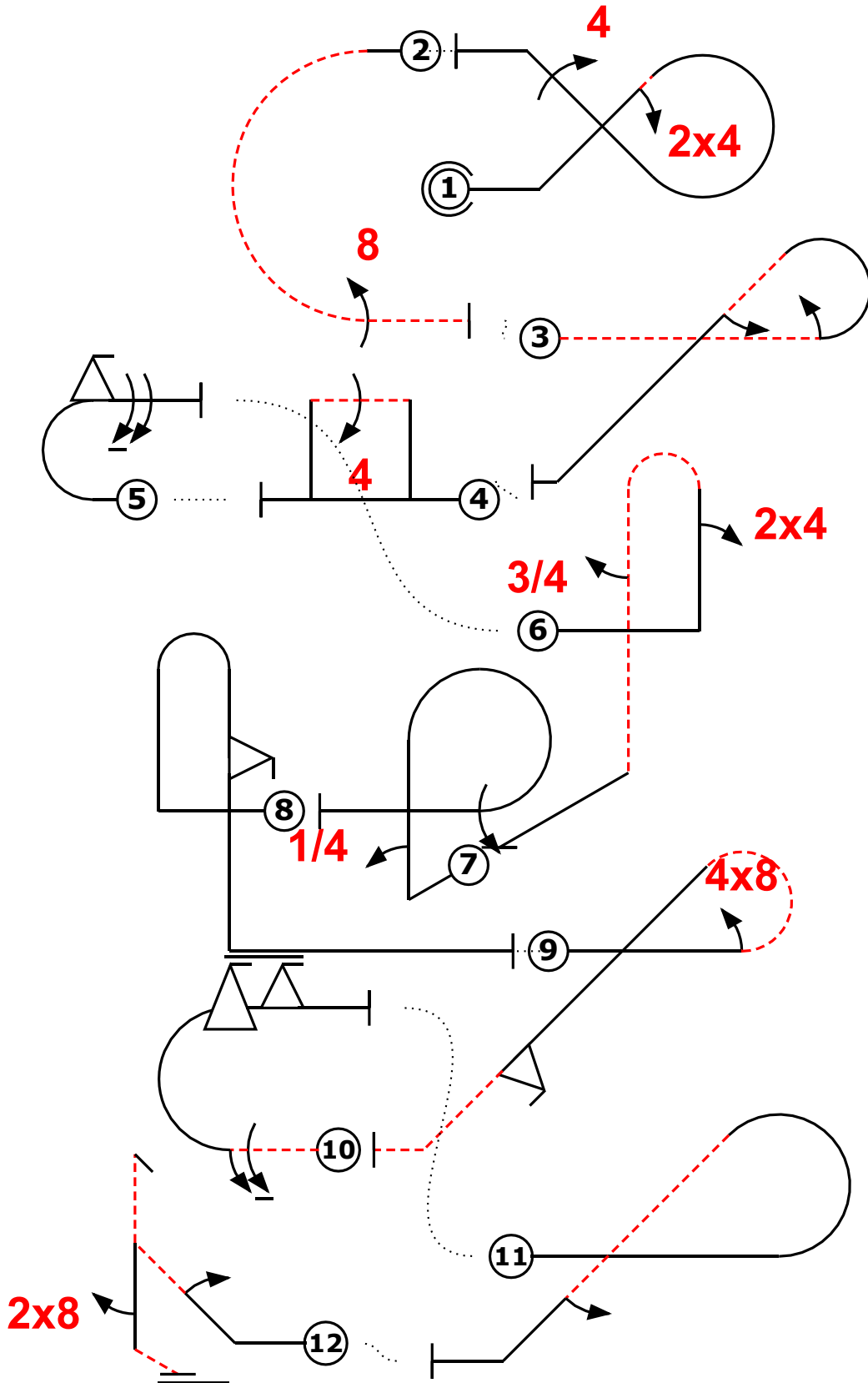

Avion			
Fig	Aresti	K	
1 G	7.3.2.1	14	34
	9.4.2.2	7	
	9.4.2.4	13	
2 I	7.2.1.3	8	23
	9.8.3.4	15	
3 Add.	8.5.8.2	11	12
	9.1.3.2	4	
	9.1.4.2	4	
4 D	7.4.3.1	14	25
	9.4.3.4	11	
5 A	7.2.2.1	6	29
	9.9.3.2	11	
	9.1.3.8	12	
6 J	8.4.3.1	15	30
	9.4.1.2	9	
	9.1.5.3	6	
7 B	8.6.1.1	11	25
	9.1.1.1	6	
	9.1.3.4	8	
8 E	8.4.1.1	13	24
	9.9.5.2	11	
9 F	8.5.8.1	14	32
	9.8.3.2	7	
	9.9.4.2	11	
10 C	7.2.4.2	6	30
	9.1.3.6	10	
	9.9.3.6	14	
11 Add.	8.5.6.1	10	12
	9.1.4.2	4	
12 H	5.3.2.3	25	34
	9.1.2.2	6	
	9.8.5.1	3	
Total K = 310			

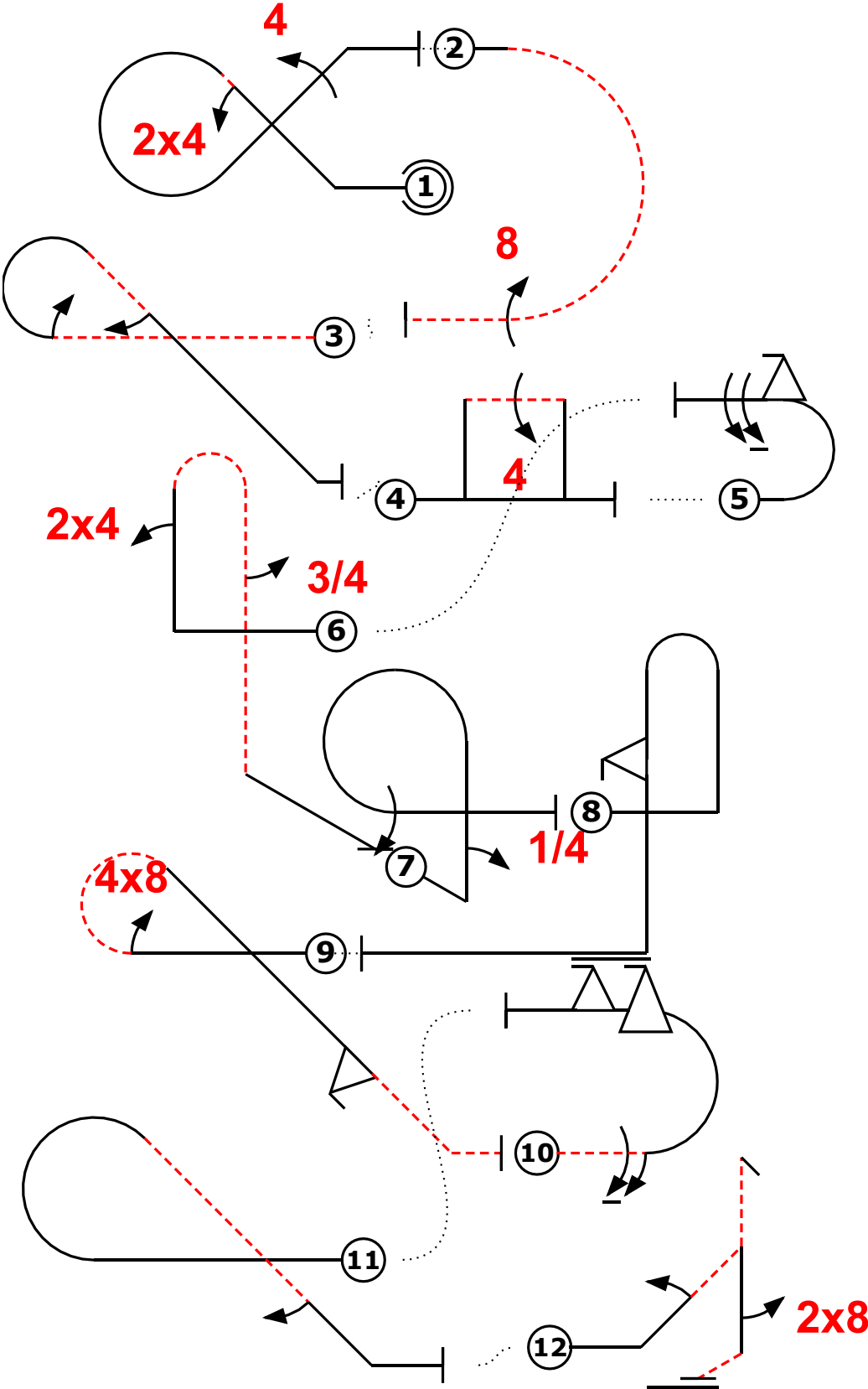

Avion			
Fig	Aresti	K	
1 G	7.3.2.1	14	34
	9.4.2.2	7	
	9.4.2.4	13	
2 I	7.2.1.3	8	23
	9.8.3.4	15	
3 Add.	8.5.8.2	11	12
	9.1.3.2	4	
	9.1.4.2	4	
4 D	7.4.3.1	14	25
	9.4.3.4	11	
5 A	7.2.2.1	6	29
	9.9.3.2	11	
	9.1.3.8	12	
6 J	8.4.3.1	15	30
	9.4.1.2	9	
	9.1.5.3	6	
7 B	8.6.1.1	11	25
	9.1.1.1	6	
	9.1.3.4	8	
8 E	8.4.1.1	13	24
	9.9.5.2	11	
9 F	8.5.8.1	14	32
	9.8.3.2	7	
	9.9.4.2	11	
10 C	7.2.4.2	6	30
	9.1.3.6	10	
	9.9.3.6	14	
11 Add.	8.5.6.1	10	12
	9.1.4.2	4	
12 H	5.3.2.3	25	34
	9.1.2.2	6	
	9.8.5.1	3	
Total K = 310			

Chesneau Pilote  
 F-HMKF E330SC  
 Avion



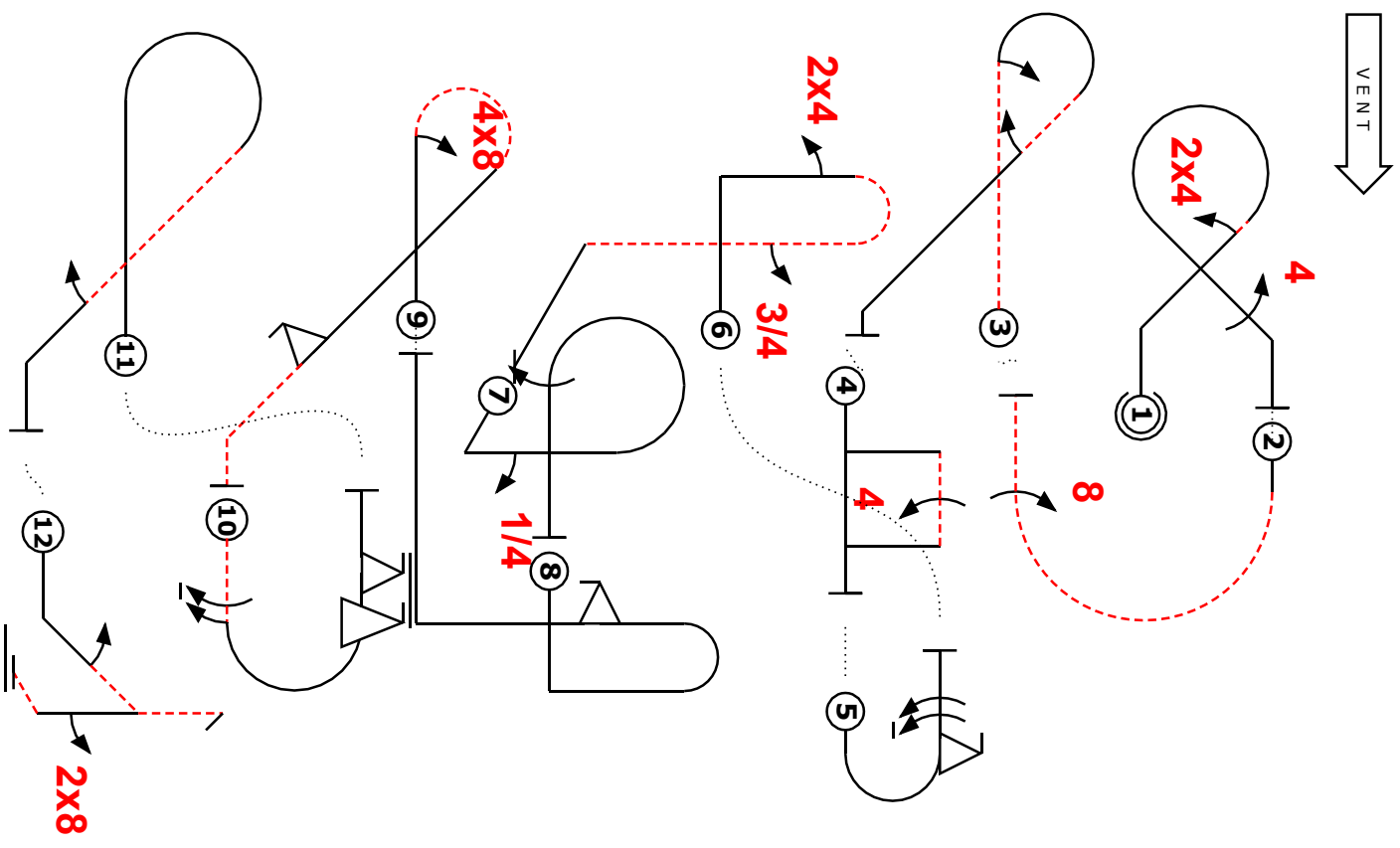
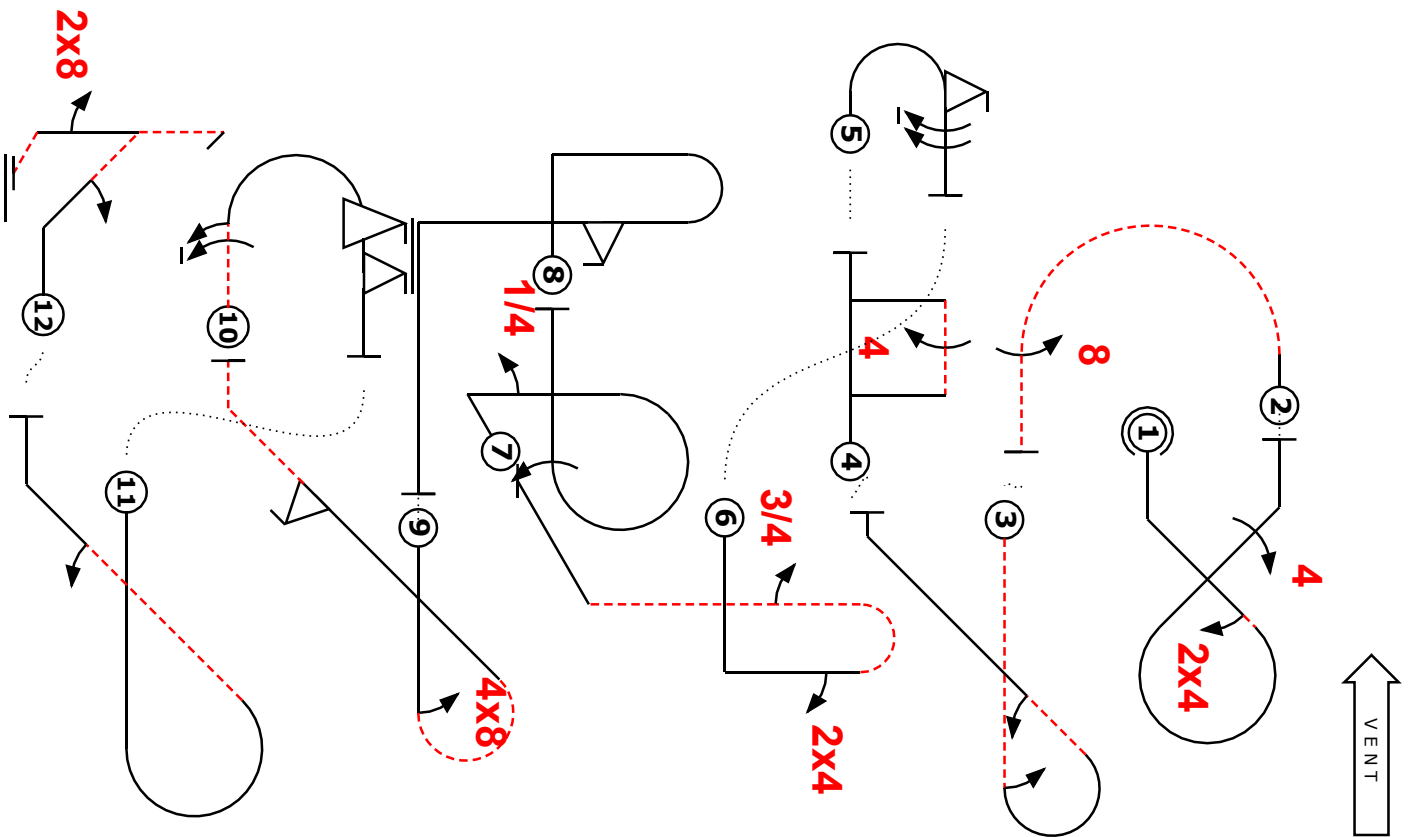

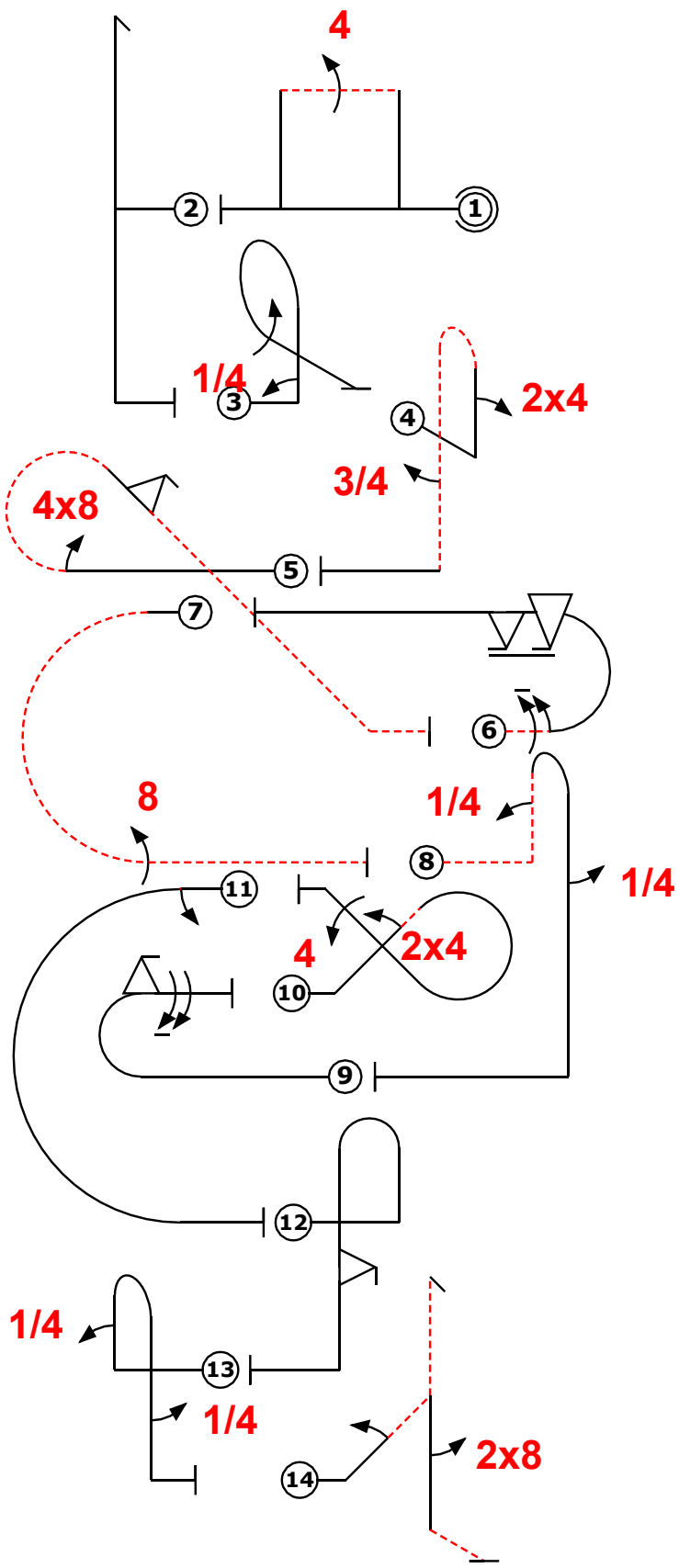

Avion			
Fig	Aresti	K	
1	7.4.3.1	14	25
D	9.4.3.4	11	
2	5.2.1.1	17	6
Add.			
3	8.6.1.1	11	25
B	9.1.1.1	6	
	9.1.3.4	8	
4	8.4.3.1	15	30
J	9.4.1.2	9	
	9.1.5.3	6	
5	8.5.8.1	14	32
F	9.8.3.2	7	
	9.9.4.2	11	
6	7.2.4.2	6	30
C	9.1.3.6	10	
	9.9.3.6	14	
7	7.2.1.3	8	23
I	9.8.3.4	15	
8	8.4.4.2	14	6
Add.			
	9.1.1.1	6	
	9.1.5.1	2	
9	7.2.2.1	6	29
A	9.9.3.2	11	
	9.1.3.8	12	
10	7.3.2.1	14	34
G	9.4.2.2	7	
	9.4.2.4	13	
11	7.2.3.3	6	6
Add.			
	9.1.3.2	4	
12	8.4.1.1	13	24
E	9.9.5.2	11	
13	8.4.1.1	13	6
Add.			
	9.1.1.1	6	
	9.1.5.1	2	
14	5.3.2.3	25	34
H	9.1.2.2	6	
	9.8.5.1	3	
Total K = 310			

*fig* ..... Pilote  
 ..... Avion

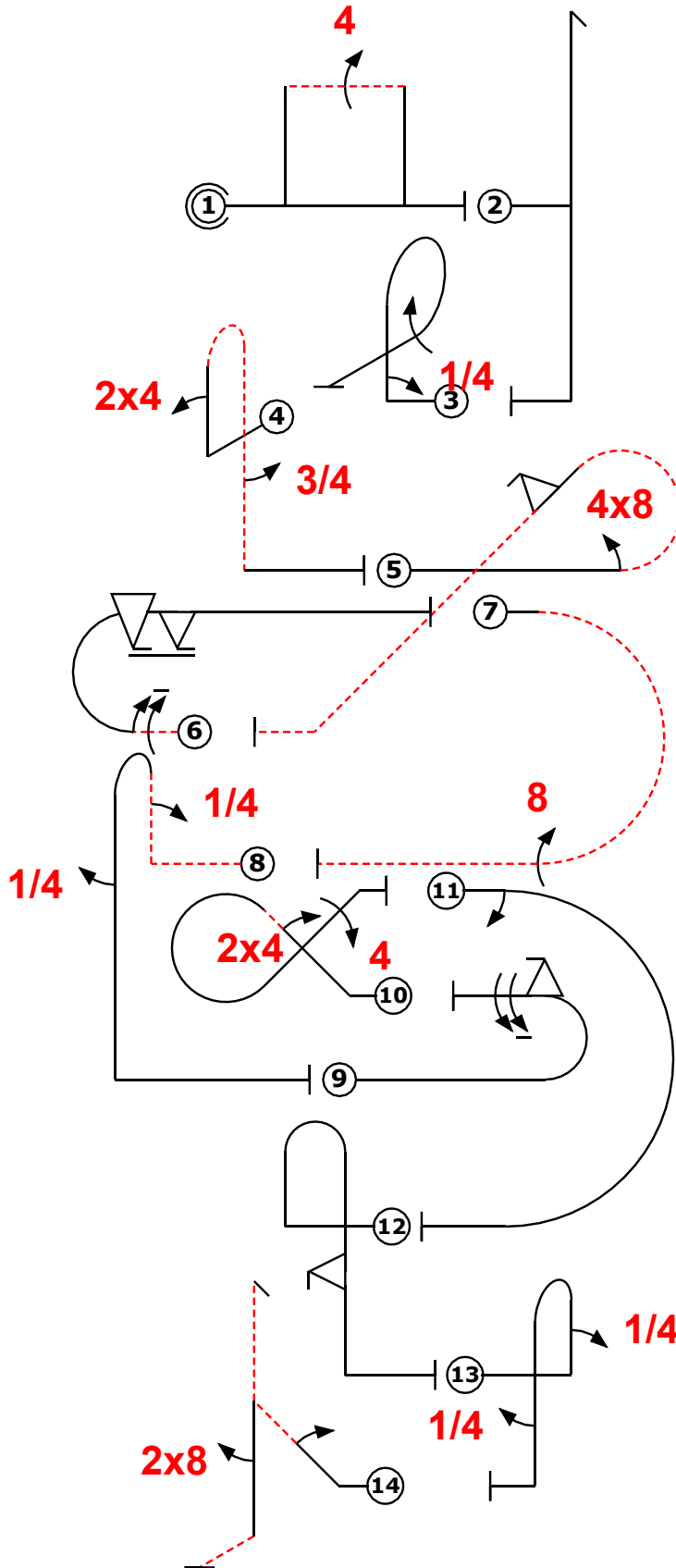

<b>Avion</b>			
Fig	Aresti	K	
1	7.4.3.1	14	25
D	9.4.3.4	11	
2	5.2.1.1	17	6
<b>Add.</b>			
3	8.6.1.1	11	25
B	9.1.1.1	6	
	9.1.3.4	8	
4	8.4.3.1	15	30
J	9.4.1.2	9	
	9.1.5.3	6	
5	8.5.8.1	14	32
F	9.8.3.2	7	
	9.9.4.2	11	
6	7.2.4.2	6	30
C	9.1.3.6	10	
	9.9.3.6	14	
7	7.2.1.3	8	23
I	9.8.3.4	15	
8	8.4.4.2	14	6
<b>Add.</b>		6	
	9.1.5.1	2	
9	7.2.2.1	6	29
A	9.9.3.2	11	
	9.1.3.8	12	
10	7.3.2.1	14	34
G	9.4.2.2	7	
	9.4.2.4	13	
11	7.2.3.3	6	6
<b>Add.</b>		4	
	9.1.3.2		
12	8.4.1.1	13	24
E	9.9.5.2	11	
13	8.4.1.1	13	6
<b>Add.</b>		6	
	9.1.5.1	2	
14	5.3.2.3	25	34
H	9.1.2.2	6	
	9.8.5.1	3	
<b>Total K = 310</b>			

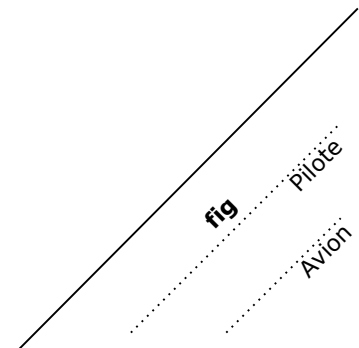

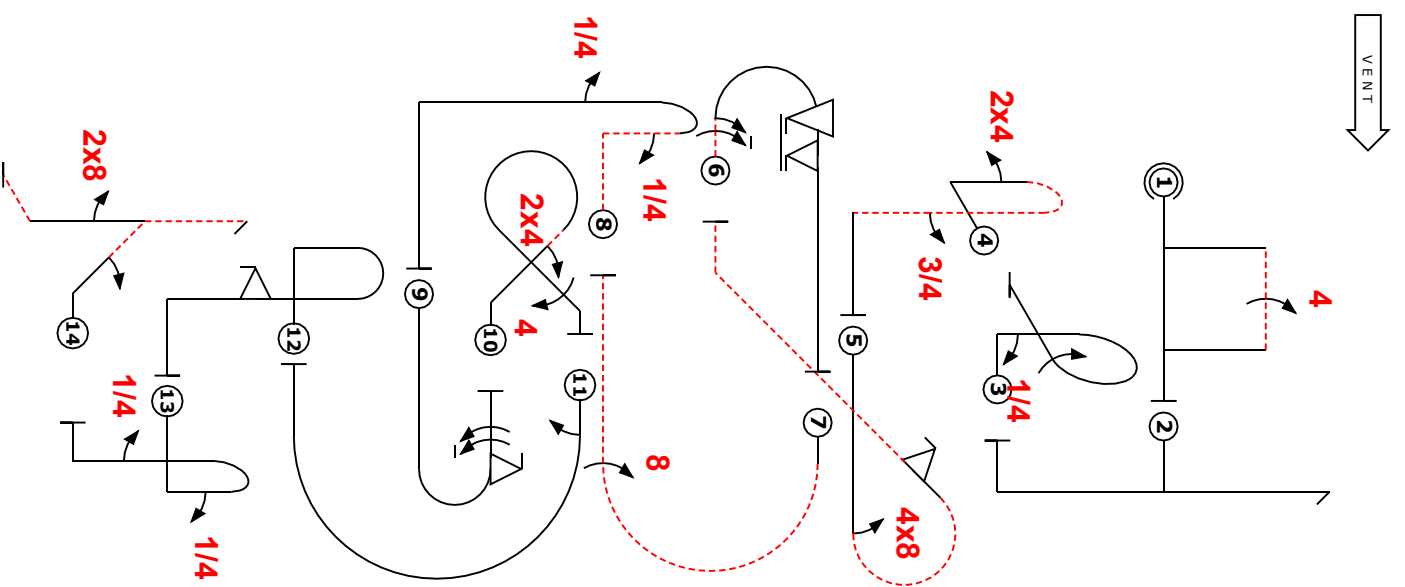
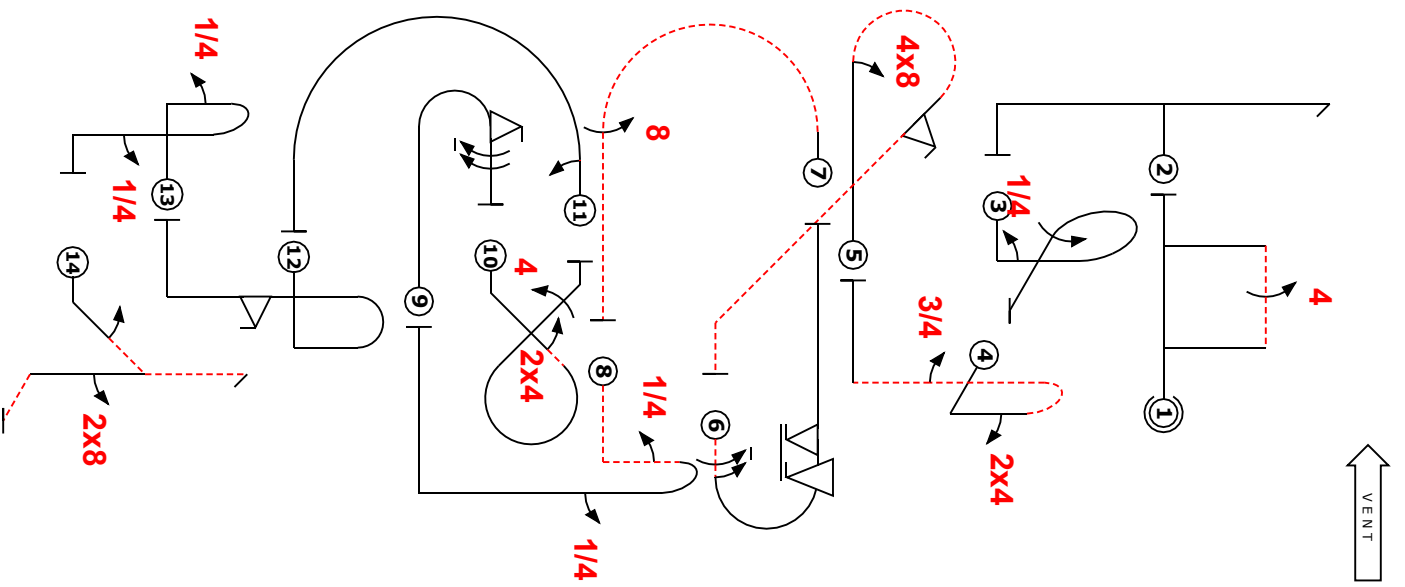



Proposition E - AVA		Form B
Pilot ID	CIVA Advanced Programme3	
		Flight #

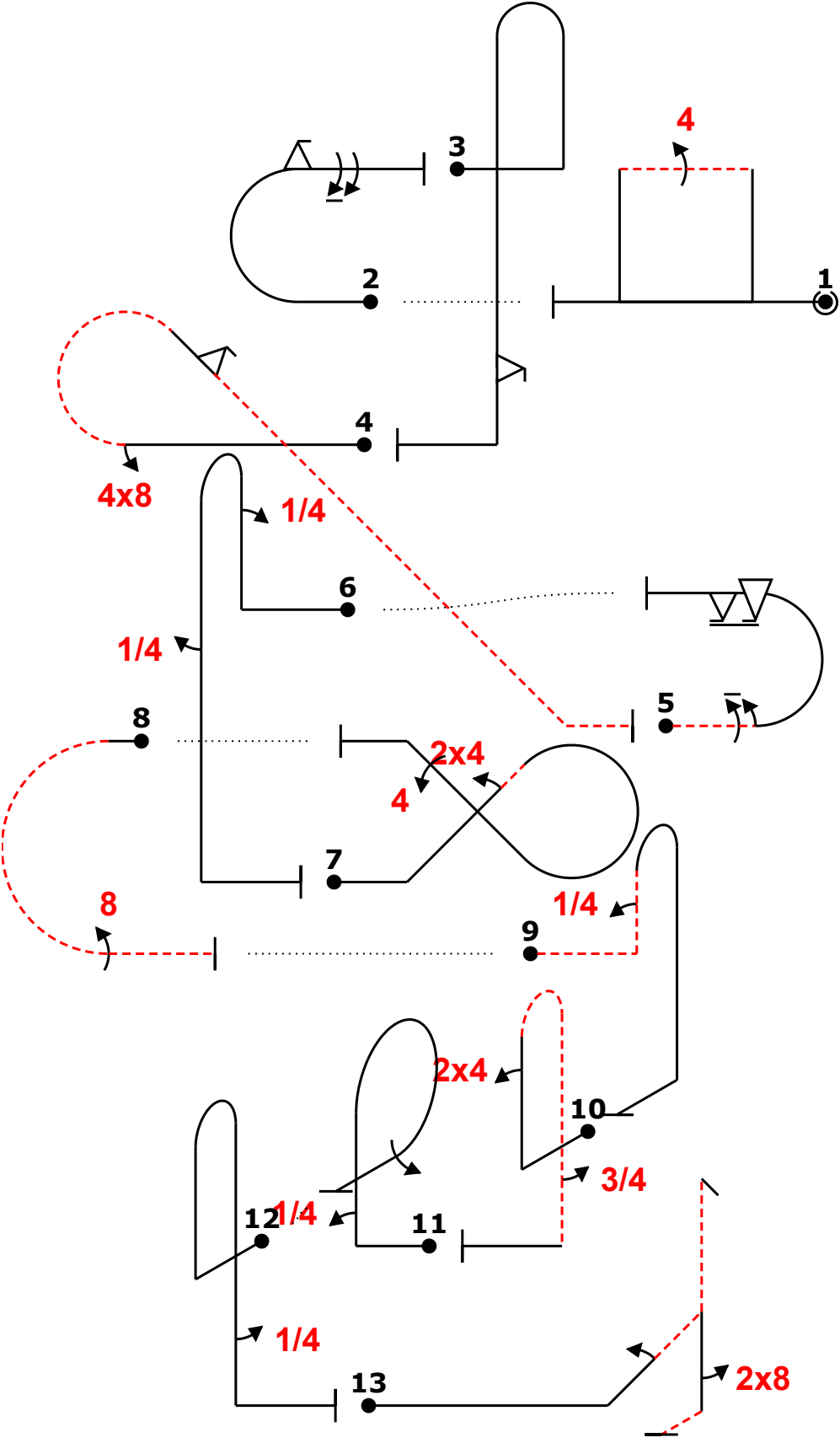
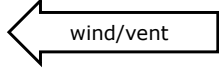

Power			
Fig	Aresti	K	
1 D	7.4.3.1 9.4.3.4	14 11	25
2 A	7.2.2.1 9.9.3.2 9.1.3.8	6 11 12	29
3 E	8.4.1.1 9.9.5.2	13 11	24
4 F	8.5.8.1 9.8.3.2 9.9.4.2	14 7 11	32
5 C	7.2.4.2 9.1.3.6 9.9.3.6	6 10 14	30
6 Add.	8.4.1.1 9.1.1.1 9.1.5.1	13 6 2	8
7 G	7.3.2.1 9.4.2.2 9.4.2.4	14 7 13	34
8 I	7.2.1.3 9.8.3.4	8 15	23
9 Add.	8.4.4.2 9.1.1.1	14 6	8
10 J	8.4.3.1 9.4.1.2 9.1.5.3	15 9 6	30
11 B	8.6.1.1 9.1.1.1 9.1.3.4	11 6 8	25
12 Add.	8.4.1.1 9.1.5.1	13 2	8
13 H	5.3.2.3 9.1.2.2 9.8.5.1	25 6 3	34
<b>Total K = 310</b>			

ed "@D" qo44 (-7,0) "@A" m2f,9 "@E" b....'2f "@F" 48c2f.....- "@C" -6m6f (-14,1) "@L" ,4b.,4... "@G" 24g44 (-8,0) "@I" 6% ....a88- (15,0) "@L" -...4b.' "@J" 24pb.'3 "@B" 4rp1 (-1,1) "@L" b..4 "@H" ~+++2dh8- eu eu eu eu eu eu eu

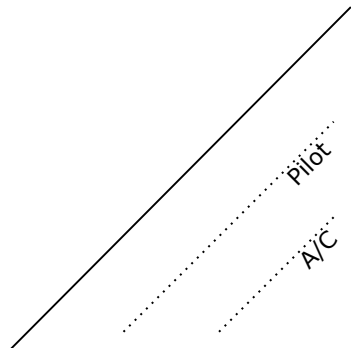



Proposition E - AVA		Form C
Pilot ID	CIVA Advanced Programme3	Flight #

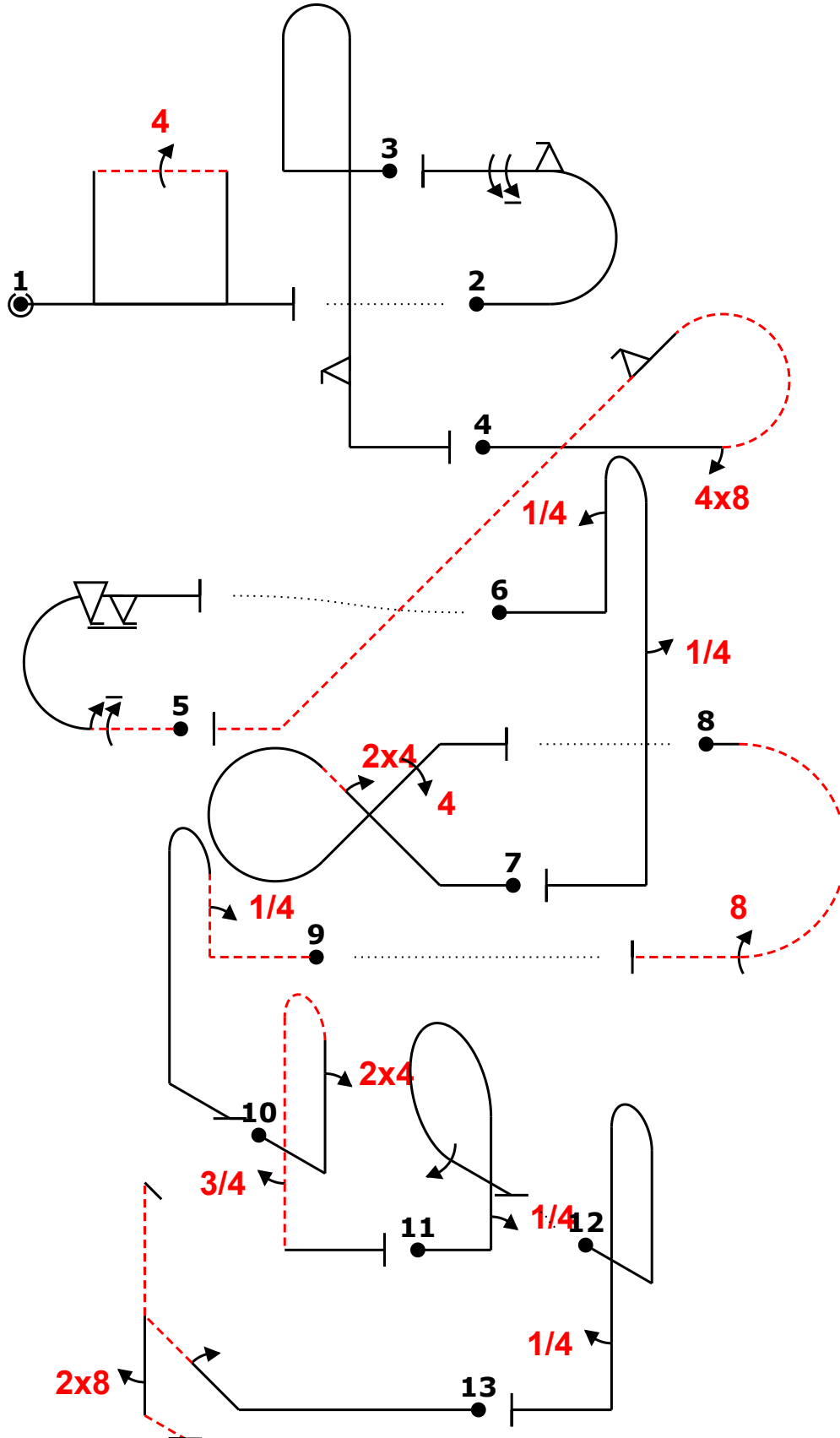
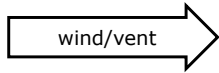

ed "@D" qo44 (-7,0) "@A" m2f,9 "@E" b....'2f "@F" 48c2f.....- "@C" -6m6f (-14,1) "@L" ,4b.,4... "@G" 24g44 (-8,0) "@I" 6% ""a88- (15,0) "@L" -""4b.' "@J" 24pb.'3 "@B" 4rp1 (-1,1) "@L" b..'4 "@H" ~++2dh8- eu eu eu eu eu eu eu

Pilot  
A/C

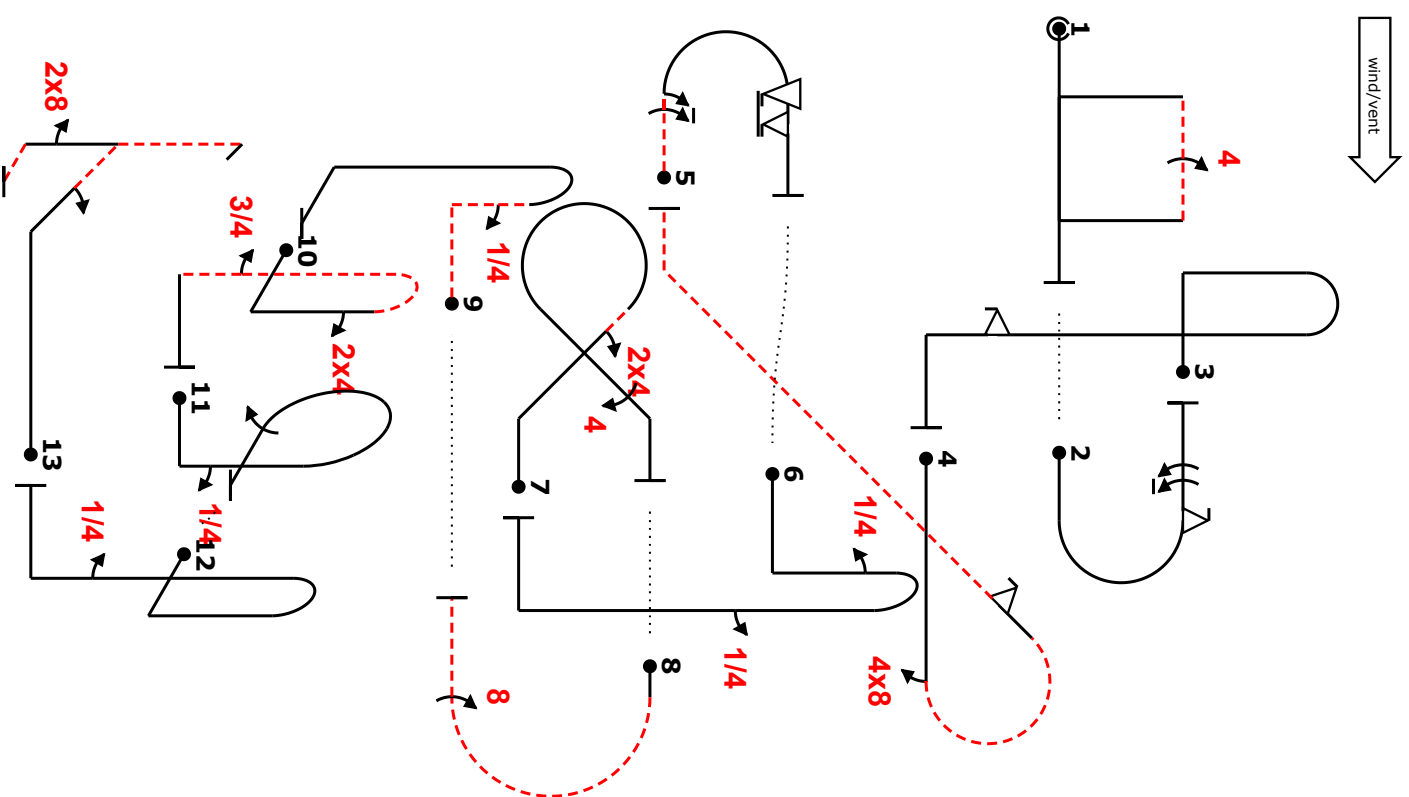
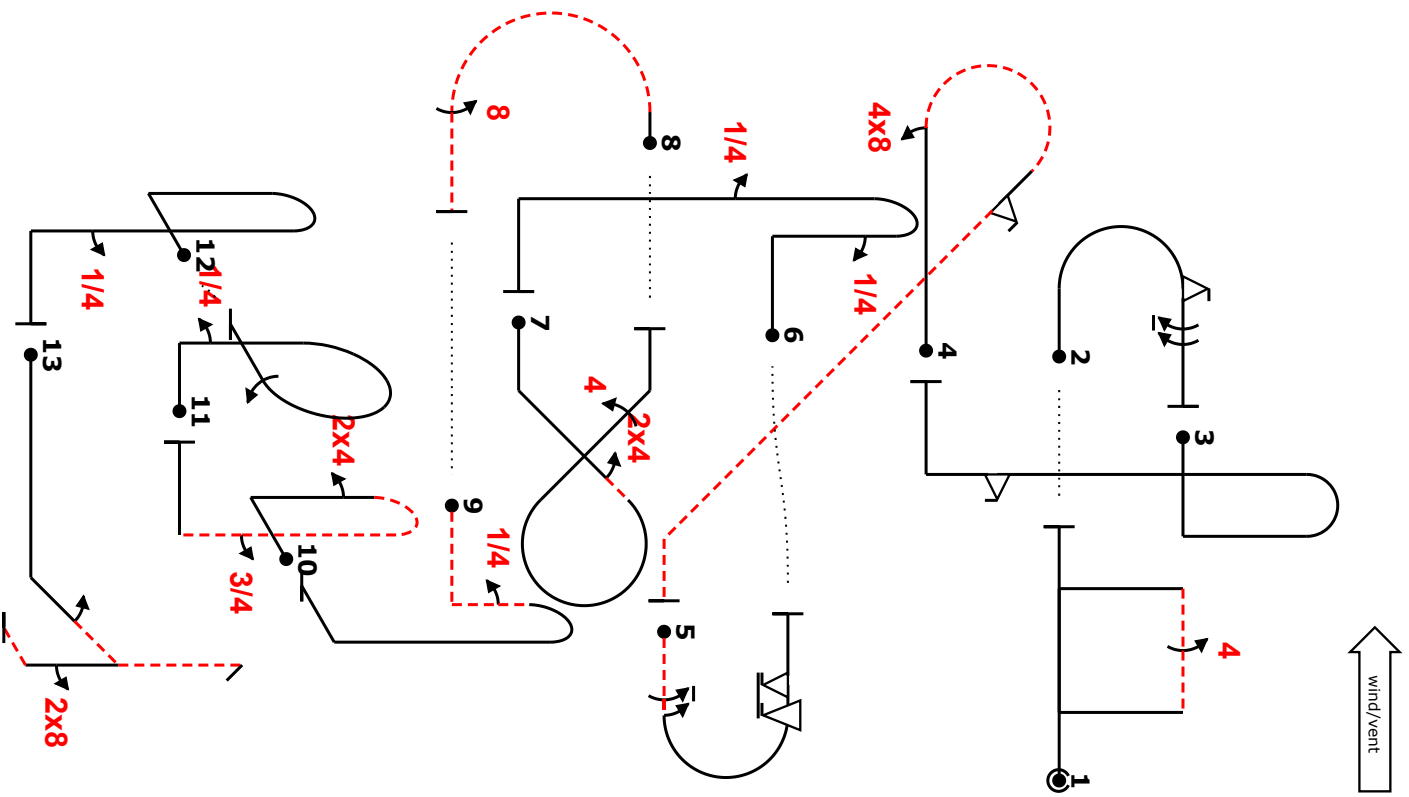

Pilot ID

France Advanced inconnu-libre 2

Flight #

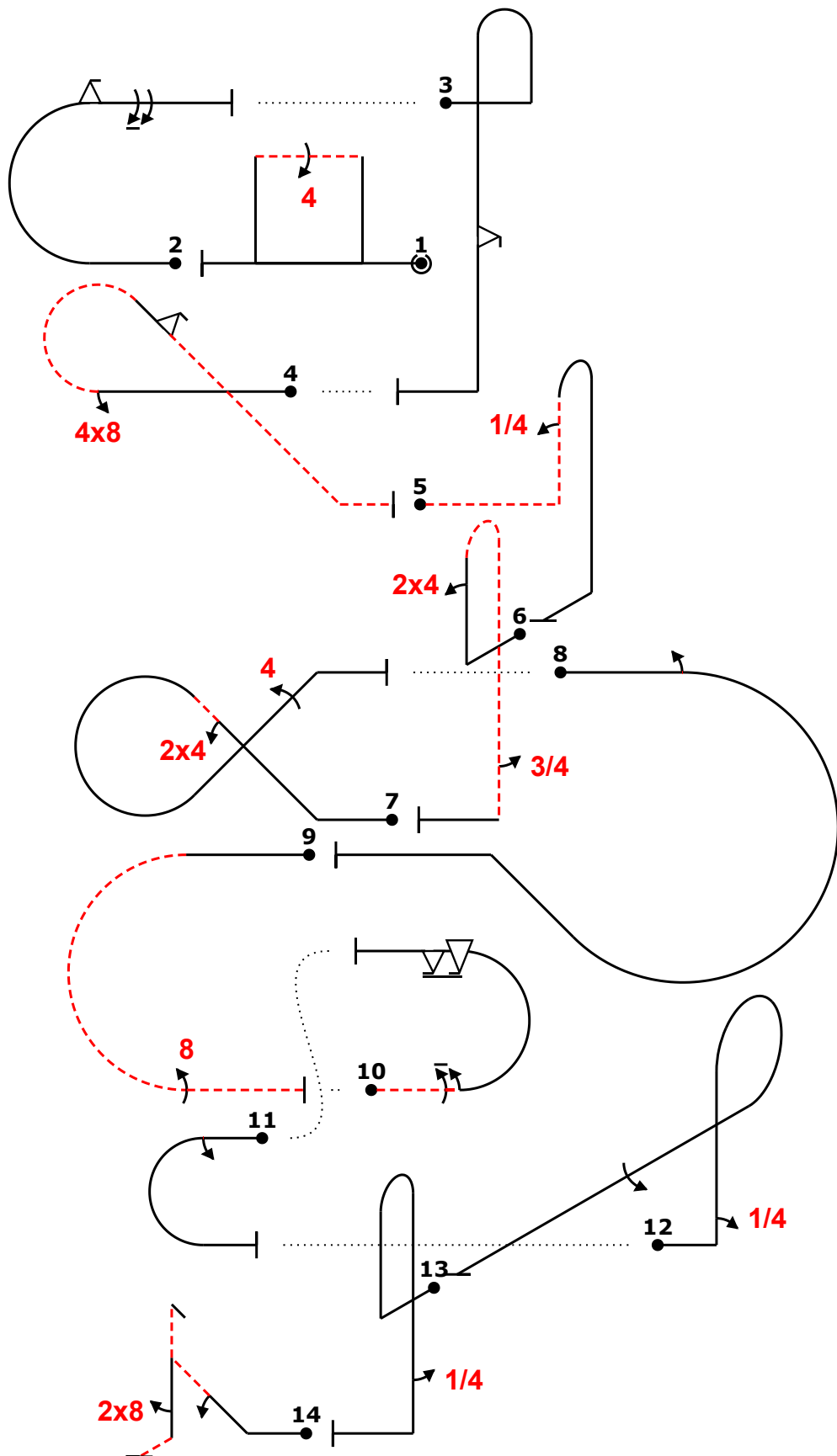
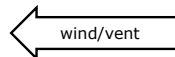

Power			
Fig	Aresti	K	
1 D	7.4.3.1	14	25
	9.4.3.4	11	
2 A	7.2.2.1	6	29
	9.9.3.2	11	
	9.1.3.8	12	
3 E	8.4.1.1	13	24
	9.9.5.2	11	
4 F	8.5.8.1	14	32
	9.8.3.2	7	
	9.9.4.2	11	
5 Add.	8.4.4.2	14	6
	9.1.1.1	6	
6 J	8.4.3.1	15	30
	9.4.1.2	9	
	9.1.5.3	6	
7 G	7.3.2.1	14	34
	9.4.2.2	7	
	9.4.2.4	13	
8 Add.	8.5.7.3	10	6
	9.1.3.2	4	
9 I	7.2.1.3	8	23
	9.8.3.4	15	
10 C	7.2.4.2	6	30
	9.1.3.6	10	
	9.9.3.6	14	
11 Add.	7.2.3.3	6	6
	9.1.3.2	4	
12 B	8.6.1.1	11	25
	9.1.1.1	6	
	9.1.3.4	8	
13 Add.	8.4.1.1	13	6
	9.1.5.1	2	
14 H	5.3.2.3	25	34
	9.1.2.2	6	
	9.8.5.1	3	
<b>Total K = 310</b>			

Pilot  
A/C



Proposition F - AVA		Form C
Pilot ID	France Advanced inconnu-libre 2	Flight #

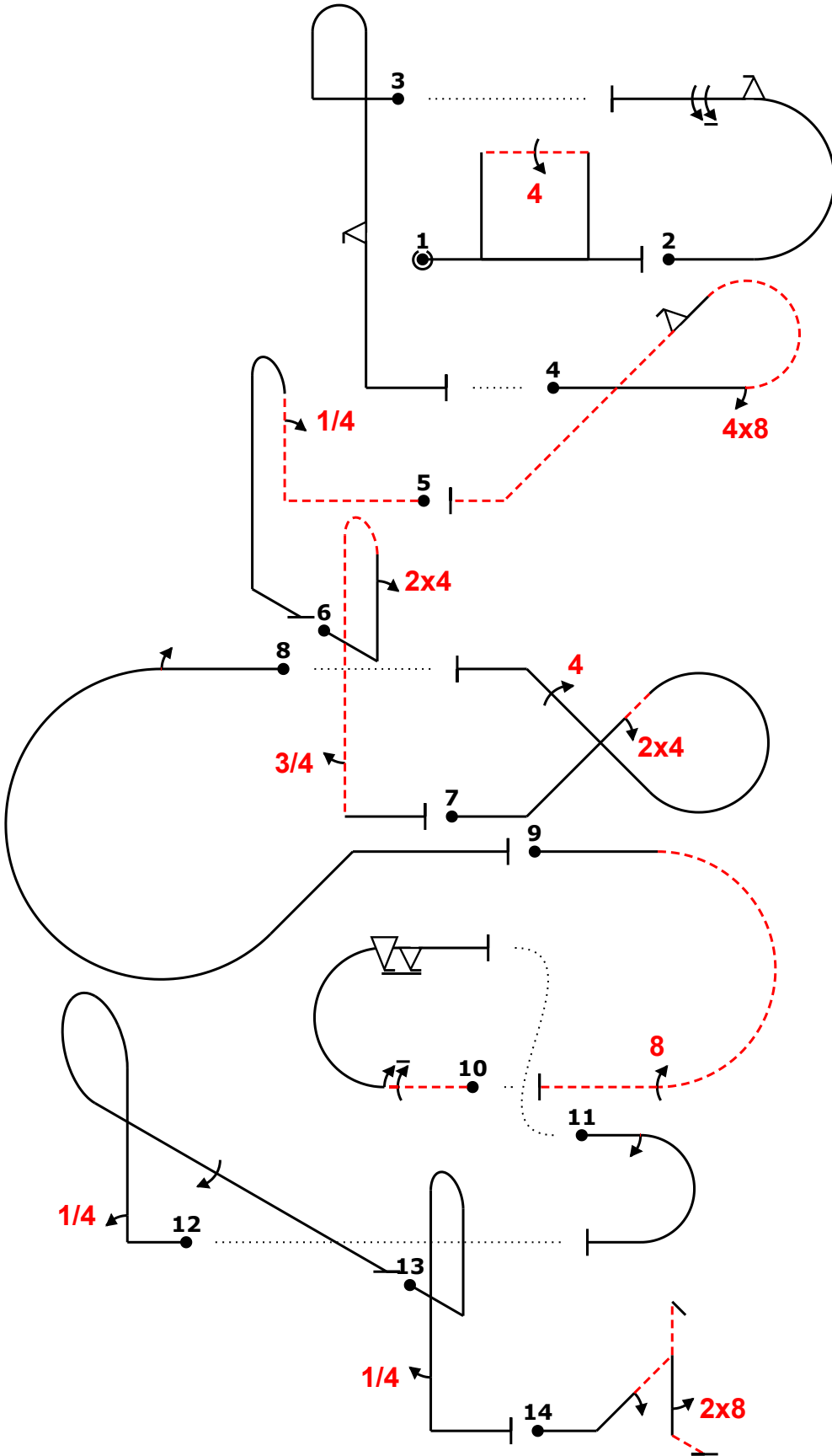

Pilot  
A/C

