

Pilote ID

France Desavois/promotion libre

Vol N°

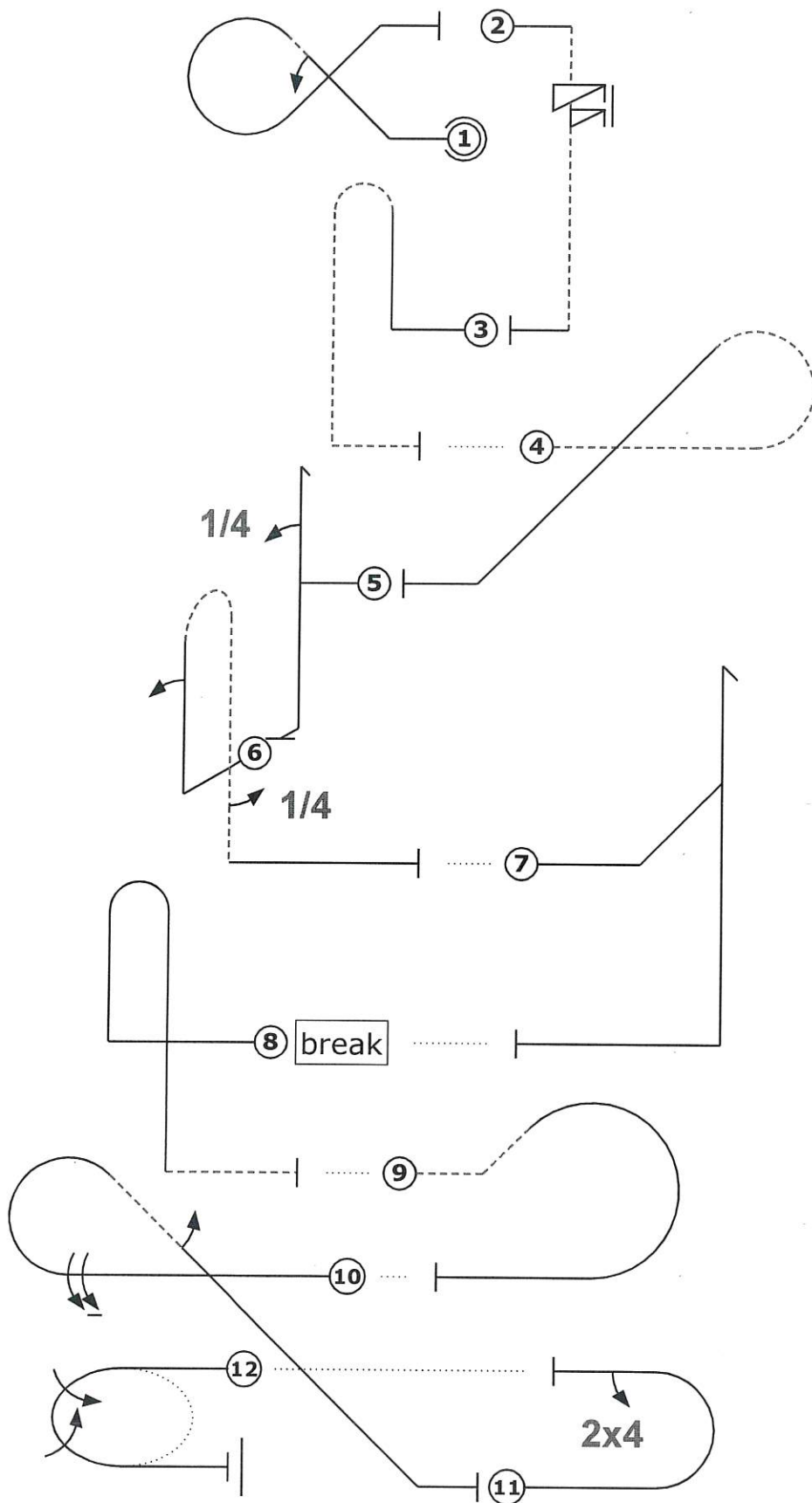

Avion

Fig	Aresti	K	
1	7.3.2.1 9.1.2.2	14 6	20
2	1.1.6.3 9.11.1.6	10 3	13
3	8.4.4.1	16	16
4	8.5.5.2	12	12
5	5.2.1.1 9.1.1.1	17 6	23
6	8.4.3.1 9.1.1.2 9.1.5.1	15 8 2	25
7	5.3.1.1	18	18
8	8.4.2.1	14	14
9	8.5.1.2	10	10
10	8.5.6.1 9.1.3.8 9.1.4.2	10 12 4	26
11	7.2.2.1 9.4.3.2	6 5	11
12	2.2.5.1	12	12

Total K = 200
(max K = 200)

Le K Aresti normal de la figure 12 a été changé selon le règlement 2022 france desavois/promotion libre

W. Thibaud

WILHELM Thibaud
Pilote
CR100
Avion

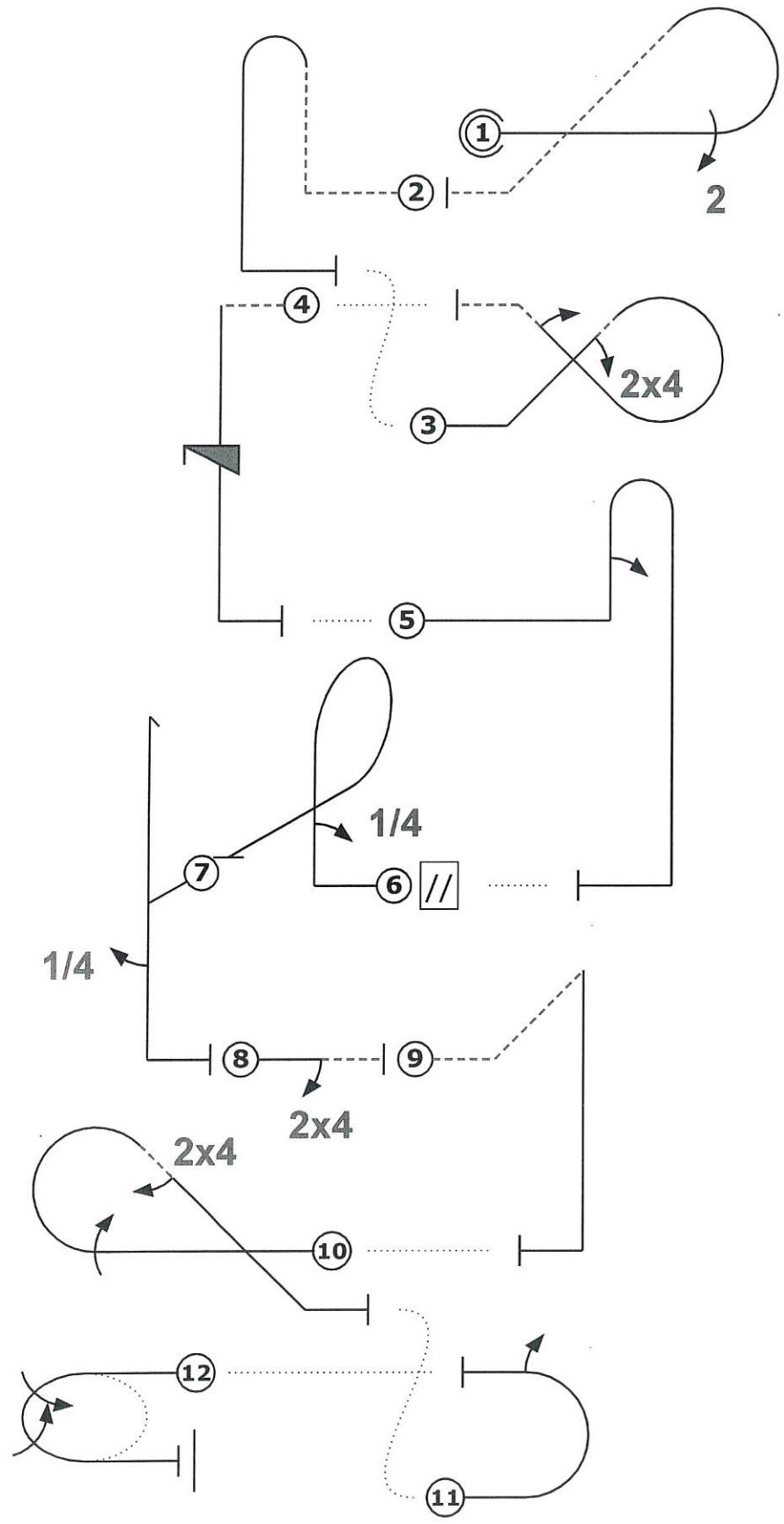

Avion			
Fig	Aresti	K	
1	8.5.5.1 9.2.3.4	10 9	19
2	8.4.4.2	14	14
3	7.3.4.1 9.4.2.2 9.1.2.2	16 7 6	29
4	1.1.7.4 9.12.1.4	9 7	16
5	8.4.1.1 9.1.1.2	13 8	21
6	8.6.1.1 9.1.1.1	11 6	17
7	5.2.1.1 9.1.5.1	17 2	19
8	1.1.1.3 9.4.3.2	2 5	7
9	1.2.2.2	13	13
10	8.5.6.1 9.1.3.4 9.4.4.2	10 8 5	23
11	7.2.2.1 9.1.3.2	6 4	10
12	2.2.5.1	12	12
Total K = 200 (max K = 200)			
Le K Aresti normal de la figure 12 a été changé selon le règlement 2022 france desavois/promotion libre			

XABADA

CAP10C F-GYLR Pilote
Avion

Pilote ID

France Desavois/promotion libre

Voi N°

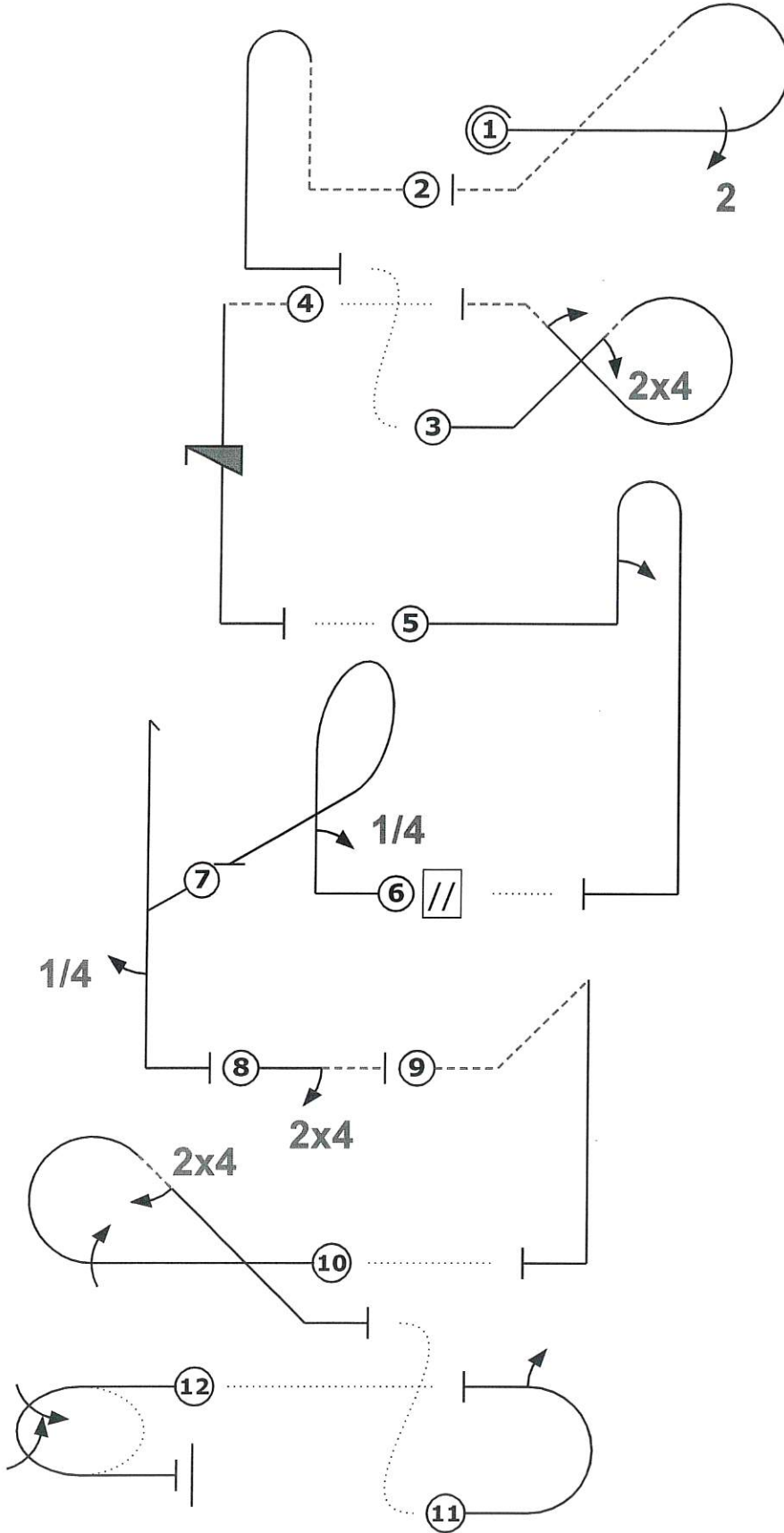

Avion			
Fig	Aresti	K	
1	8.5.5.1 9.2.3.4	10 9	19
2	8.4.4.2	14	14
3	7.3.4.1 9.4.2.2 9.1.2.2	16 7 6	29
4	1.1.7.4 9.12.1.4	9 7	16
5	8.4.1.1 9.1.1.2	13 8	21
6	8.6.1.1 9.1.1.1	11 6	17
7	5.2.1.1 9.1.5.1	17 2	19
8	1.1.1.3 9.4.3.2	2 5	7
9	1.2.2.2	13	13
10	8.5.6.1 9.1.3.4 9.4.4.2	10 8 5	23
11	7.2.2.1 9.1.3.2	6 4	10
12	2.2.5.1	12	12
Total K = 200 (max K = 200)			
Le K Aresti normal de la figure 12 a été changé selon le règlement 2022 france desavois/promotion libre			

SAIZY
CAP10C F-GYLR
Avion
Pilote

		Form B
Pilote ID	France Desavois/promotion libre	Vol N°

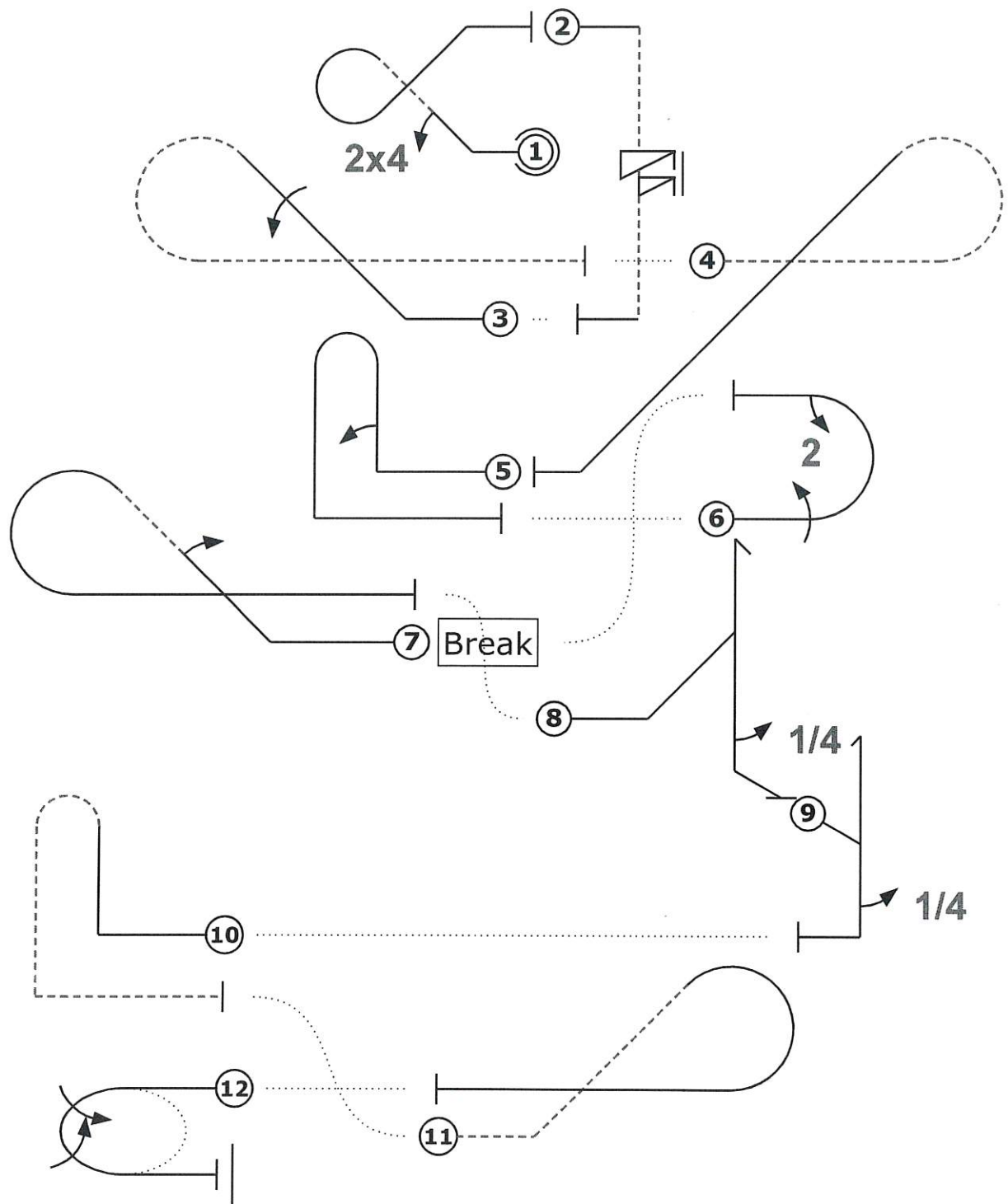

Avion			
Fig	Aresti	K	
1	7.3.2.1 9.4.2.2	14 7	21
2	1.1.6.3 9.11.1.6	10 3	13
3	8.5.1.1 9.1.2.4	12 10	22
4	8.5.5.2	12	12
5	8.4.1.1 9.1.1.2	13 8	21
6	7.2.2.1 9.1.3.4 9.1.3.2	6 8 4	18
7	8.5.2.1 9.1.2.2	10 6	16
8	5.3.1.1 9.1.5.1	18 2	20
9	5.2.1.1 9.1.5.1	17 2	19
10	8.4.4.1	16	16
11	8.5.1.2	10	10
12	2.2.5.1	12	12
Total K = 200 (max K = 200)			
Le K Aresti normal de la figure 12 a été changé selon le règlement 2022 france desavois/promotion libre			

LECLERCQ Pilote
AP
 Avion
Emile

		Form C
Pilote ID	France Desavois/promotion libre	Vol N°

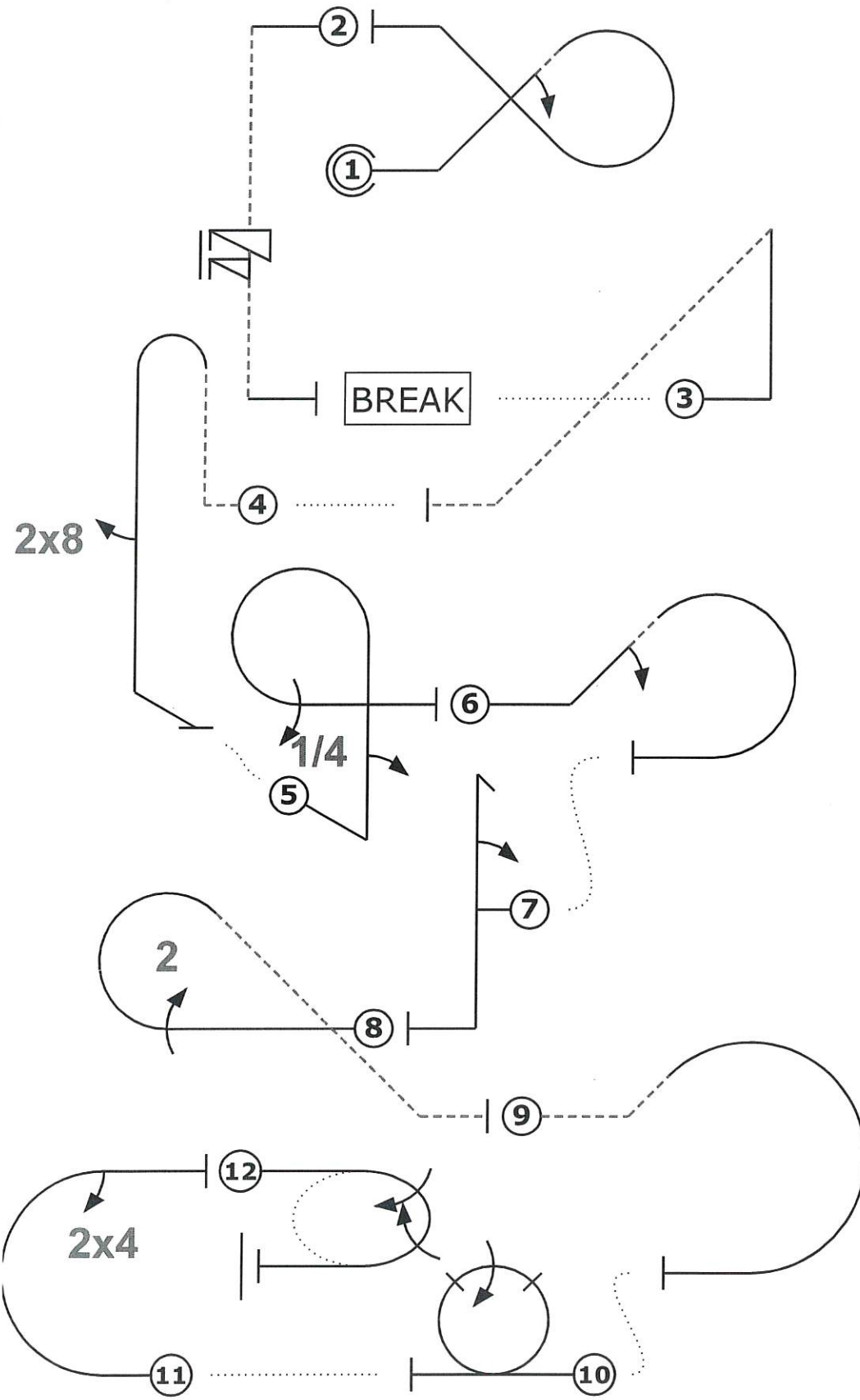

Avion			
Fig	Aresti	K	
1	7.3.2.1 9.1.2.2	14 6	20
2	1.1.6.3 9.11.1.6	10 3	13
3	1.2.5.1	14	14
4	8.4.4.2 9.8.5.1	14 3	17
5	8.6.1.1 9.1.1.1 9.1.3.4	11 6 8	25
6	8.5.2.1 9.1.2.2	10 6	16
7	5.2.1.1 9.1.1.2	17 8	25
8	8.5.5.1 9.2.3.4	10 9	19
9	8.5.1.2	10	10
10	7.4.1.1 9.1.3.4	10 8	18
11	7.2.2.1 9.4.3.2	6 5	11
12	2.2.5.1	12	12
Total K = 200 (max K = 200)			
Le K Aresti normal de la figure 12 a été changé selon le règlement 2022 france desavois/promotion libre			

LANEN
31/05/23
[Signature]

LANEN Pilote
CAP 10 F-GYKA Avion

Pilote ID

France Desavois/promotion libre

Vol N°

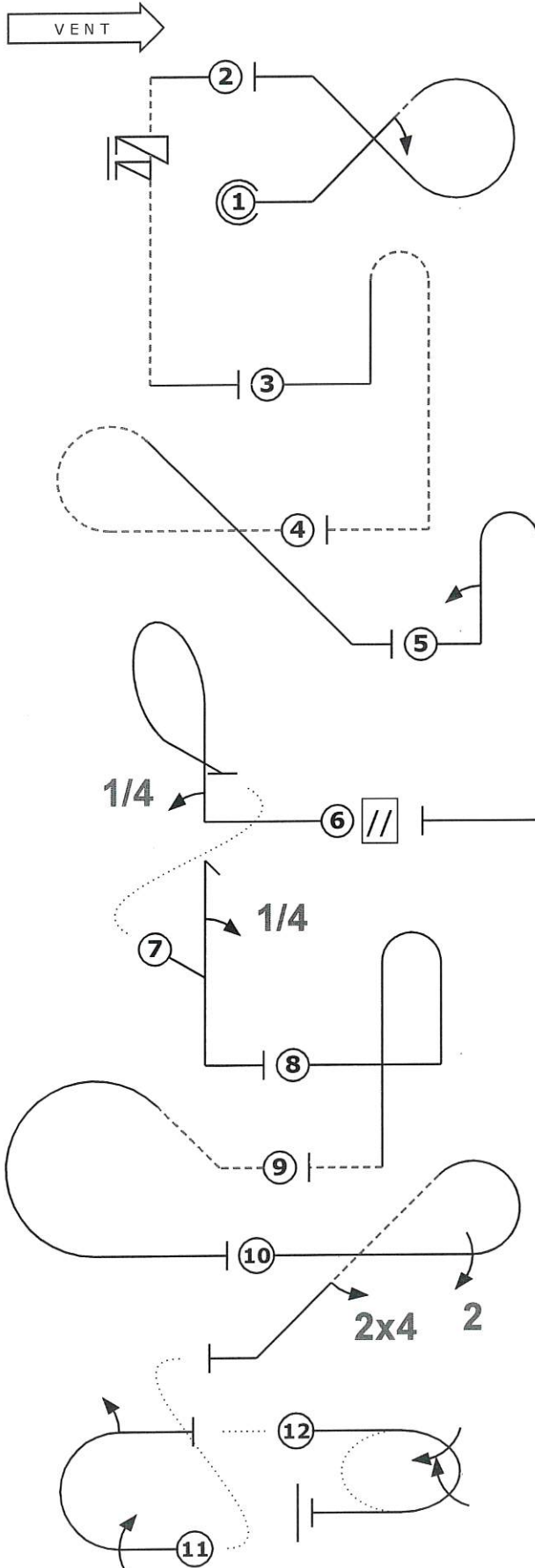

Avion			
Fig	Aresti	K	
1	7.3.2.1 9.1.2.2	14 6	20
2	1.1.6.3 9.11.1.6	10 3	13
3	8.4.4.1	16	16
4	8.5.5.2	12	12
5	8.4.1.1 9.1.1.2	13 8	21
6	8.6.1.1 9.1.1.1	11 6	17
7	5.2.1.1 9.1.1.1	17 6	23
8	8.4.2.1	14	14
9	8.5.1.2	10	10
10	8.5.6.1 9.2.3.4 9.4.4.2	10 9 5	24
11	7.2.2.1 9.1.3.4 9.1.3.2	6 8 4	18
12	2.2.5.1	12	12

Total K = 200
(max K = 200)

Le K Aresti normal de la figure 12 a été changé selon le règlement 2022 france desavois/promotion libre

David HOARAU
Pilote
CAP 10 C FG GYL
Avion

Hoarau

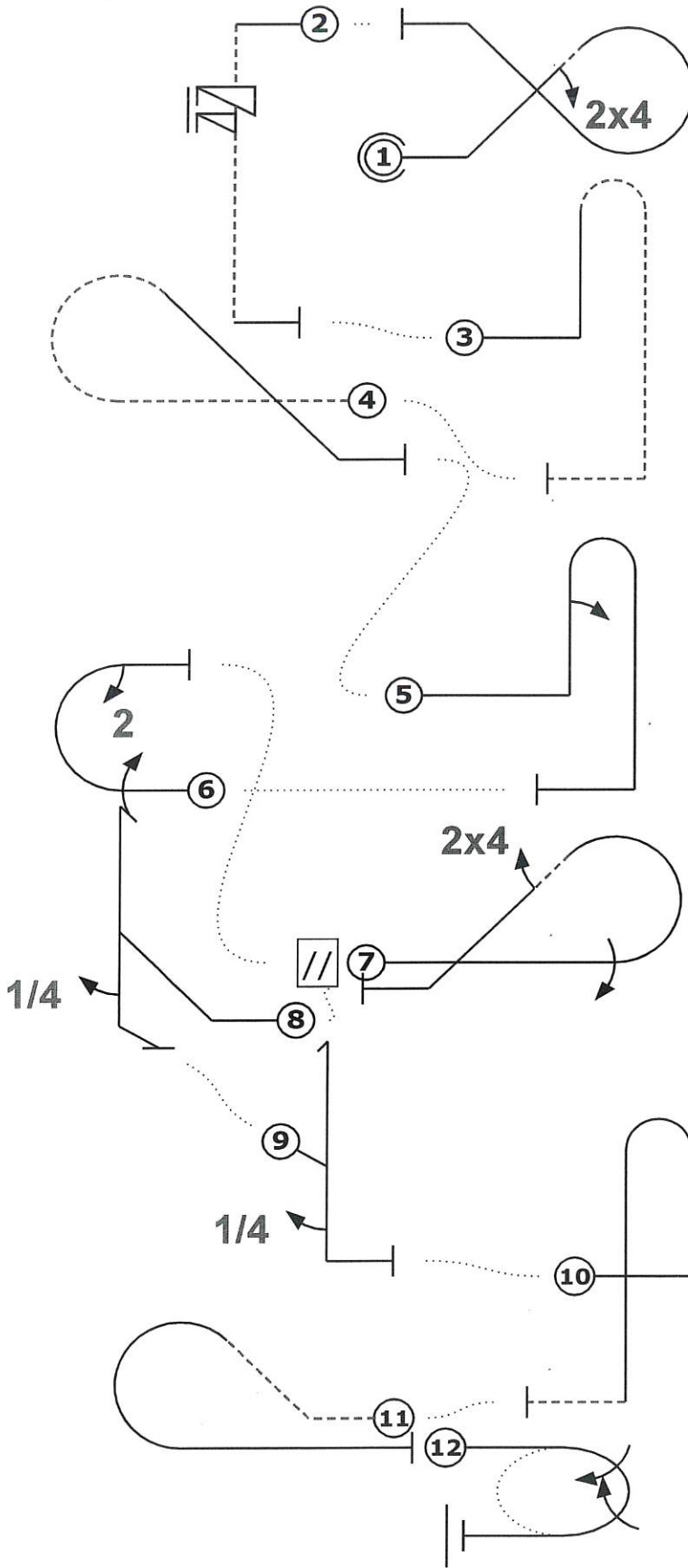

Figure K
200

K total
215

Nom des Juges		Vol N°
Signature	Numéro	

Fig	Grade	Pos	Remarks
1	.		
2	.		
3	.		
4	.		
5	.		
6	.		
7	.		
8	.		
9	.		
10	.		
11	.		
12	.		

Cadre(Coef)
15

Trop Bas		Echauf. non OK	
Trop Haut		Battem. d'Ailes	
Interruptions		Disqualifié	
Insertions		Autre(noter...)	

Le K Aresti normal de la figure 12 a été changé selon le règlement 2022 france desavois/promotion libre

Fig 1	K	Fig 2	K	Fig 3	K	Fig 4	K	Fig 5	K	Fig 6	K	Fig 7	K	Fig 8	K	Fig 9	K	Fig 10	K	Fig 11	K	Fig 12	K
7.3.2.1	14	1.1.6.3	10	8.4.4.1	16	8.5.5.2	12	8.4.1.1	13	7.2.2.1	6	8.5.6.1	10	5.3.1.1	18	5.2.1.1	17	8.4.2.1	14	8.5.1.2	10	2.2.5.1	12
9.4.2.2	7	9.11.1.6	3					9.1.1.2	8	9.2.3.4	9	9.1.3.4	8	9.1.5.1	2	9.1.5.1	2						
SF 7	21	SF 3	13	SF 7	16	SF 7	12	SF 7	21	SF 7	19	SF 7	23	SF 5	20	SF 5	19	SF 7	14	SF 7	10	SF 2	12

Pilote: Gabriel Hirsch

Avion: Cap10 F-PCAP

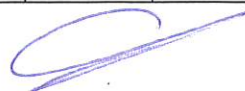

		Form C
Pilote ID	France Desavois/promotion libre	
		Vol N°

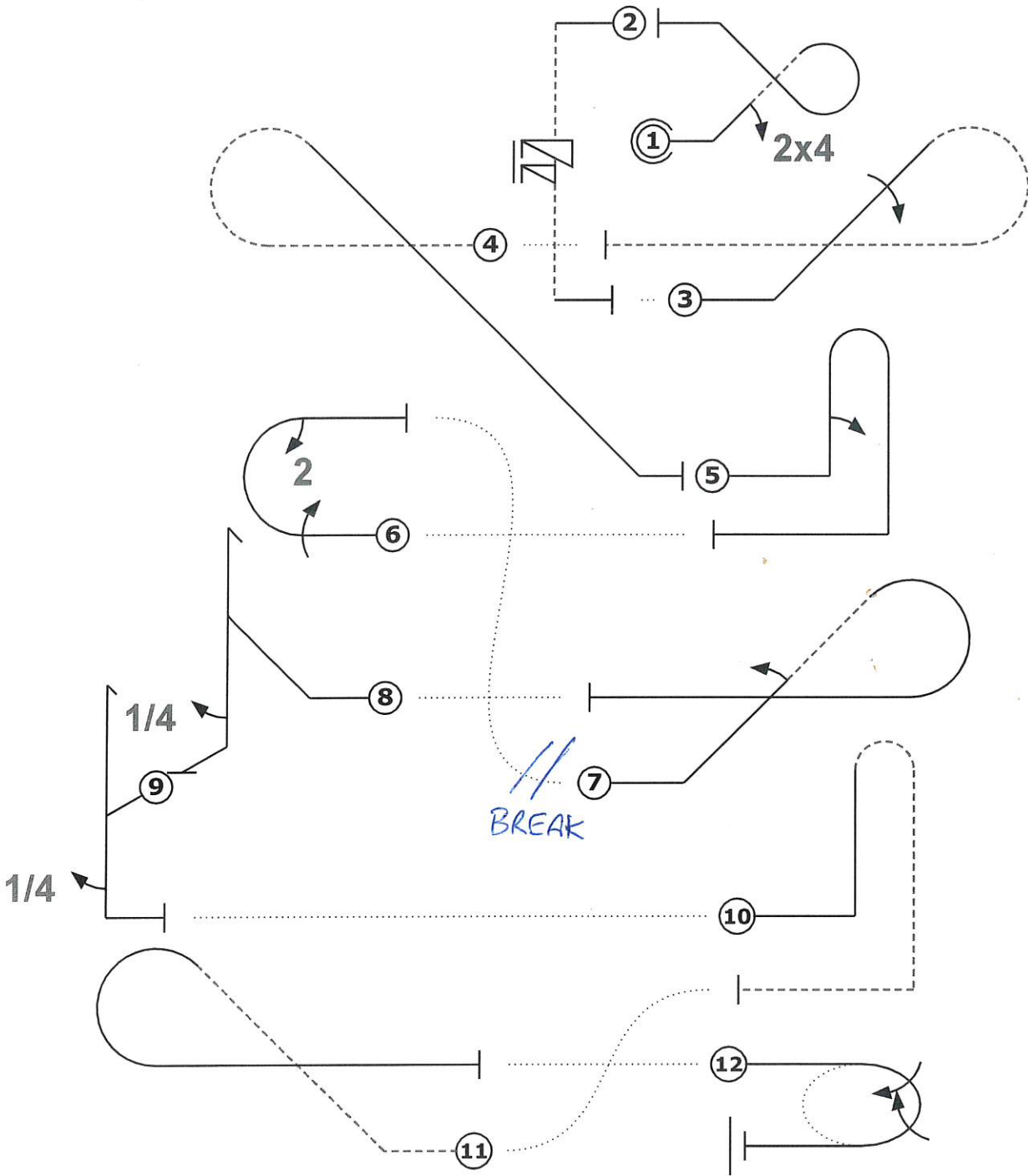

Avion			
Fig	Aresti	K	
1	7.3.2.1 9.4.2.2	14 7	21
2	1.1.6.3 9.11.1.6	10 3	13
3	8.5.1.1 9.1.2.4	12 10	22
4	8.5.5.2	12	12
5	8.4.1.1 9.1.1.2	13 8	21
6	7.2.2.1 9.1.3.4 9.1.3.2	6 8 4	18
7	8.5.2.1 9.1.2.2	10 6	16
8	5.3.1.1 9.1.5.1	18 2	20
9	5.2.1.1 9.1.5.1	17 2	19
10	8.4.4.1	16	16
11	8.5.1.2	10	10
12	2.2.5.1	12	12

Total K = 200
(max K = 200)

Le K Aresti normal de la figure 12 a été changé selon le règlement 2022 france desavois/promotion libre



 Timothé DECROUX Pilote
 CAP10-C F-GGYJ Avion
