

Avion			
Fig	Aresti	K	
1	5.2.1.3 9.4.1.2	18 9	27
2	7.2.3.2 9.1.3.2 9.9.3.4	7 4 11	22
3	1.1.7.4 9.12.1.4	9 7	16
4	8.5.5.1 9.2.3.4	10 9	19
5	5.2.1.4 9.1.5.1	22 2	24
6	8.4.1.1 9.1.1.1	13 6	19
7	5.3.1.1	18	18
8	8.5.7.1 9.2.3.6	12 12	24
9	5.2.1.1	17	17
10	1.2.7.1 9.4.4.2	13 5	18
11	8.4.3.1 9.1.1.2	15 8	23
12	7.2.1.1 9.1.3.4	6 8	14
13	2.4.7.2	19	19
<b>Total K = 260</b> (max K = 260)			
Le K Aresti normal de la figure 13 a été changé selon le règlement 2022 france national_2 libre			

*Handwritten signature in blue ink.*

		Form C
Pilote ID	France National_2 libre	
		Vol N°

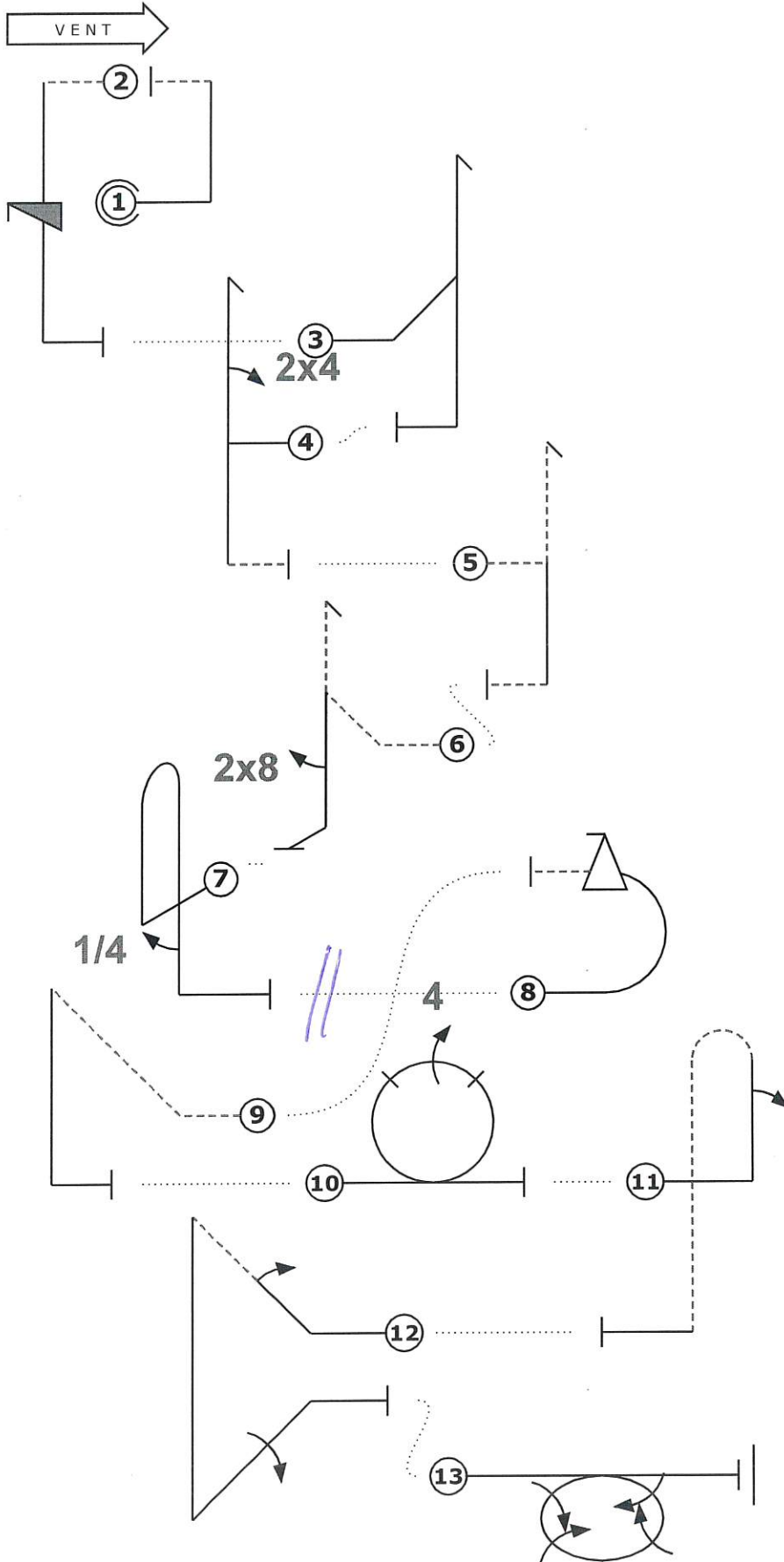

Avion			
Fig	Aresti	K	
1	1.1.7.1	9	9
2	1.1.7.4 9.12.1.4	9 7	16
3	5.3.1.1	18	18
4	5.2.1.3 9.4.1.2	18 9	27
5	5.2.1.2	23	23
6	5.3.1.4 9.8.5.1	23 3	26
7	8.4.1.1 9.1.5.1	13 2	15
8	7.2.1.1 9.9.3.4	6 11	17
9	1.2.2.2	13	13
10	7.4.1.1 9.4.3.4	10 11	21
11	8.4.3.1 9.1.1.2	15 8	23
12	1.3.2.1 9.1.2.2 9.1.2.4	18 6 10	34
13	2.4.7.1	18	18
<b>Total K = 260</b> (max K = 260)			
Le K Aresti normal de la figure 13 a été changé selon le règlement 2022 france national_2 libre			

WILHELEM FRANCOIS  
Pilote

CR100  
Avion

		Form C
Pilote ID	France National_2 libre	
		Vol N°

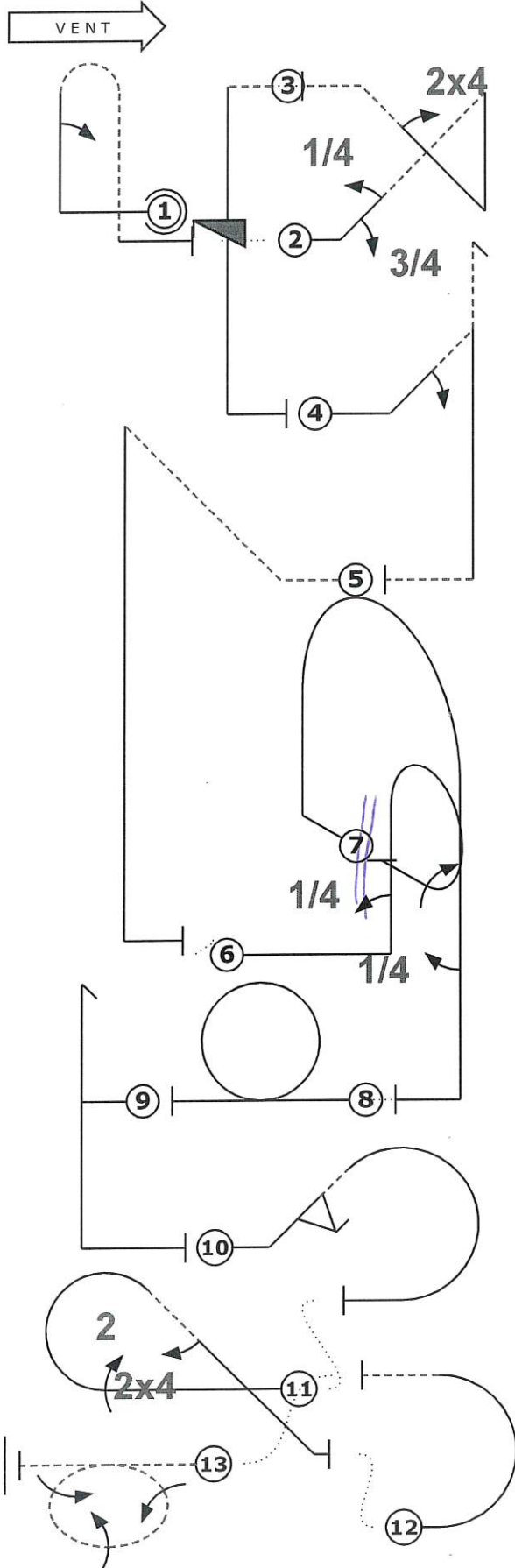

Avion			
Fig	Aresti	K	
1	8.4.3.1	15	23
	9.1.1.2	8	
2	1.3.4.1	18	37
	9.1.2.3	8	
	9.1.2.1	4	
	9.4.2.2	7	
3	1.1.7.4	9	16
	9.12.1.4	7	
4	5.3.2.3	25	31
	9.1.2.2	6	
5	1.2.2.2	13	13
6	8.6.1.1	11	25
	9.1.1.1	6	
	9.1.3.4	8	
7	8.4.1.1	13	15
	9.1.5.1	2	
8	7.4.1.1	10	10
9	5.2.1.1	17	17
10	8.5.2.1	10	23
	9.9.2.2	13	
11	8.5.6.1	10	24
	9.2.3.4	9	
	9.4.4.2	5	
12	7.2.1.1	6	6
13	2.4.5.2	20	20

**Total K = 260**  
(max K = 260)

Le K Aresti normal de la figure 13 a été changé selon le règlement 2022 france national\_2 libre

*Signature*  
**WILHELEM** Pilote  
**CR100 FPIUS** Avion

		Form C
Pilote ID	France National_2 libre	Vol N°

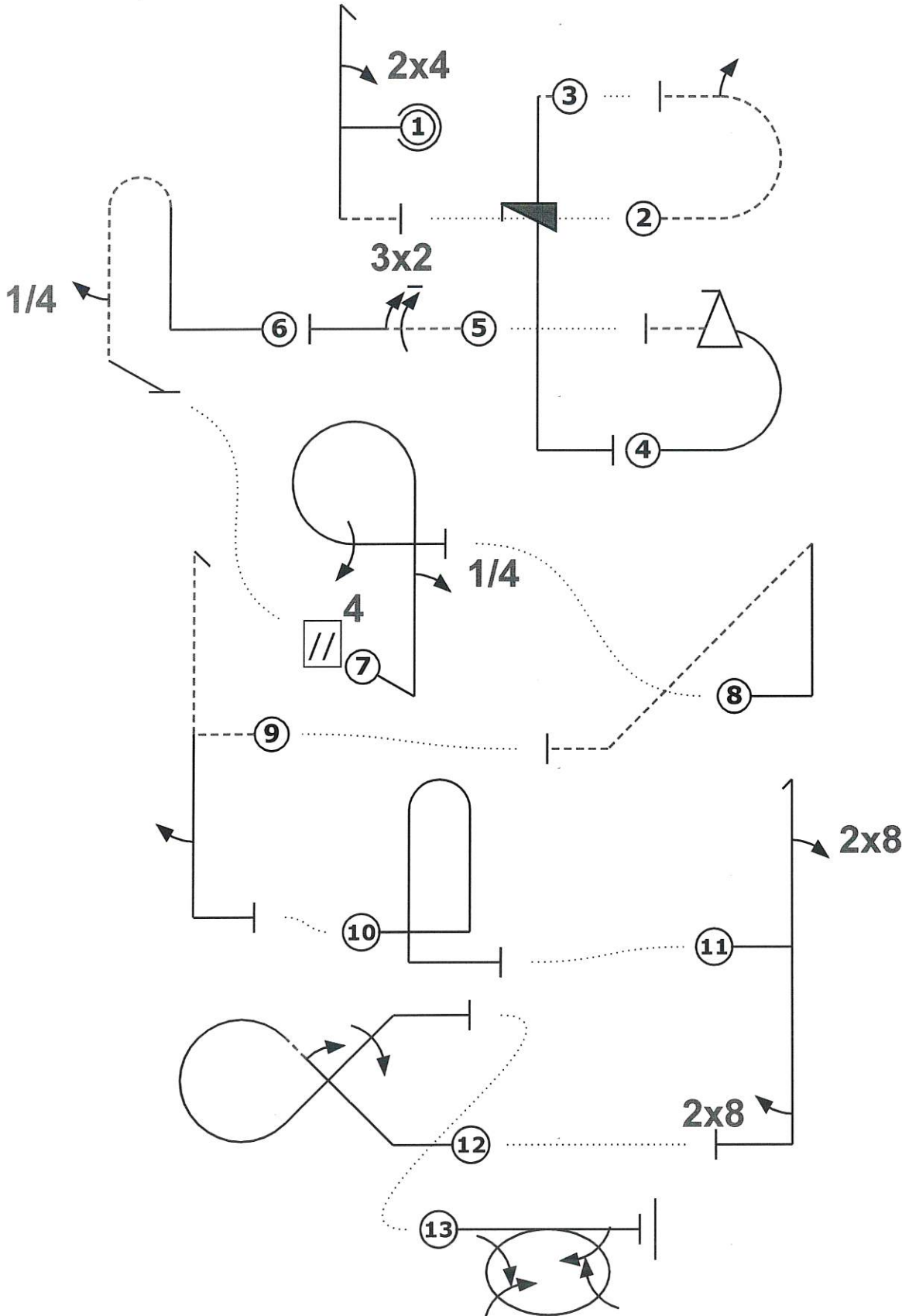

Avion			
Fig	Aresti	K	
1	5.2.1.3 9.4.1.2	18 9	27
2	7.2.2.2 9.1.3.2	9 4	13
3	1.1.7.4 9.12.1.4	9 7	16
4	7.2.1.1 9.9.3.4	6 11	17
5	1.1.1.4 9.2.3.6	2 12	14
6	8.4.3.1 9.1.5.1	15 2	17
7	8.6.1.1 9.1.1.1 9.4.3.4	11 6 11	28
8	1.2.5.1	14	14
9	5.2.1.4 9.1.5.2	22 4	26
10	8.4.1.1	13	13
11	5.2.1.1 9.8.1.1 9.8.5.1	17 7 3	27
12	7.3.2.1 9.1.2.2 9.1.2.4	14 6 10	30
13	2.4.7.1	18	18
<b>Total K = 260</b> (max K = 260)			
Le K Aresti normal de la figure 13 a été changé selon le règlement 2022 france national_2 libre			

SUISSA Pilote  
Extra 300LP F-GVSY Avion

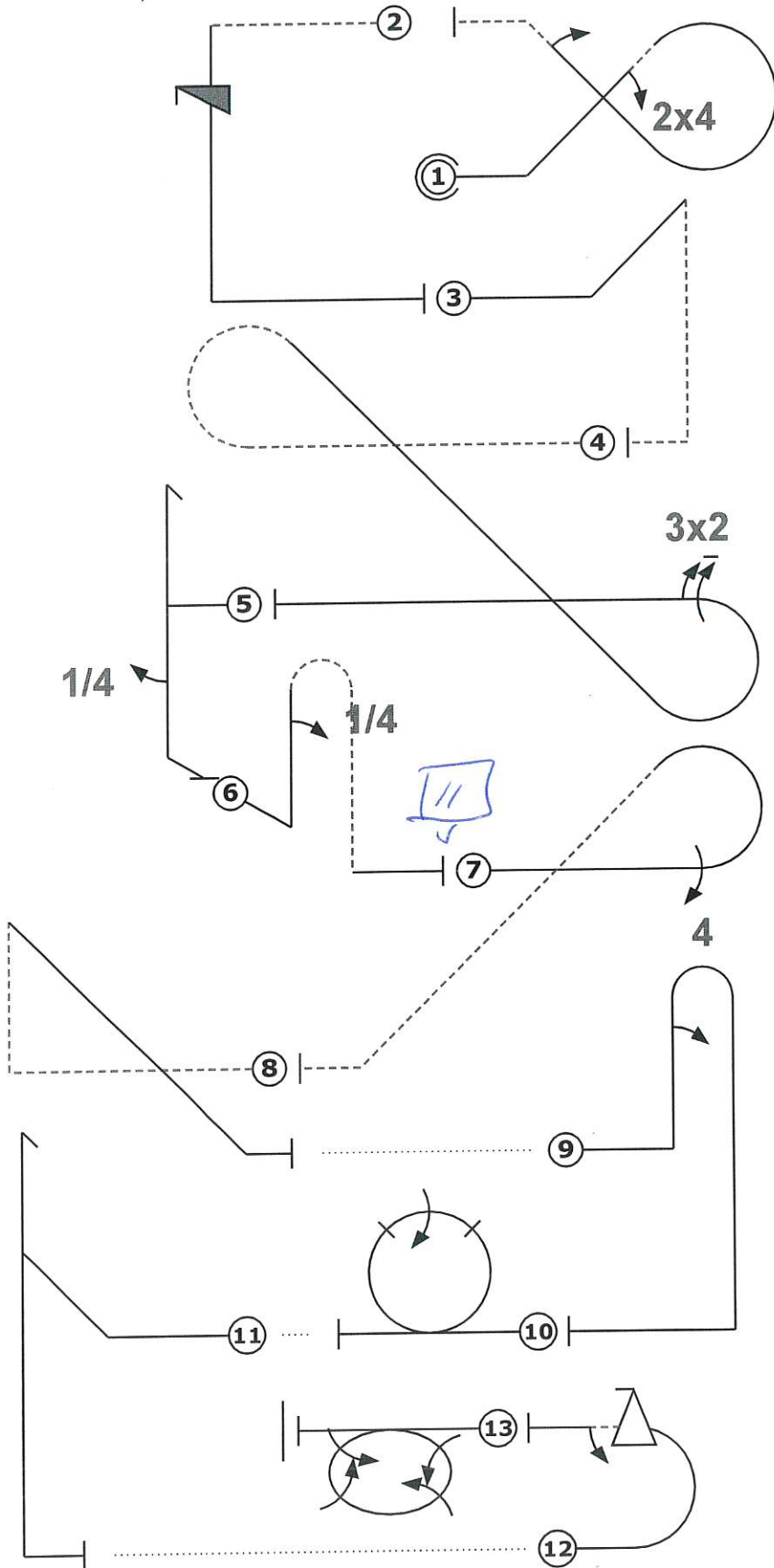

Avion			
Fig	Aresti	K	
1	7.3.4.1	16	29
	9.4.2.2	7	
	9.1.2.2	6	
2	1.1.7.4	9	16
	9.12.1.4	7	
3	1.2.2.1	14	14
4	7.5.4.2	16	28
	9.2.3.6	12	
5	5.2.1.1	17	19
	9.1.5.1	2	
6	8.4.3.1	15	21
	9.1.1.1	6	
7	8.5.5.1	10	21
	9.4.3.4	11	
8	1.2.5.2	16	16
9	8.4.1.1	13	21
	9.1.1.2	8	
10	7.4.1.1	10	18
	9.1.3.4	8	
11	5.3.1.1	18	18
12	7.2.2.1	6	21
	9.9.3.4	11	
	9.1.3.2	4	
13	2.4.7.1	18	18
<b>Total K = 260</b> (max K = 260)			
Le K Aresti normal de la figure 13 a été changé selon le règlement 2022 france national_2 libre			

*Benneux*  
 LEMAIRE Pilote  
 CR100 FPIUS Avion  
 Coupe ?

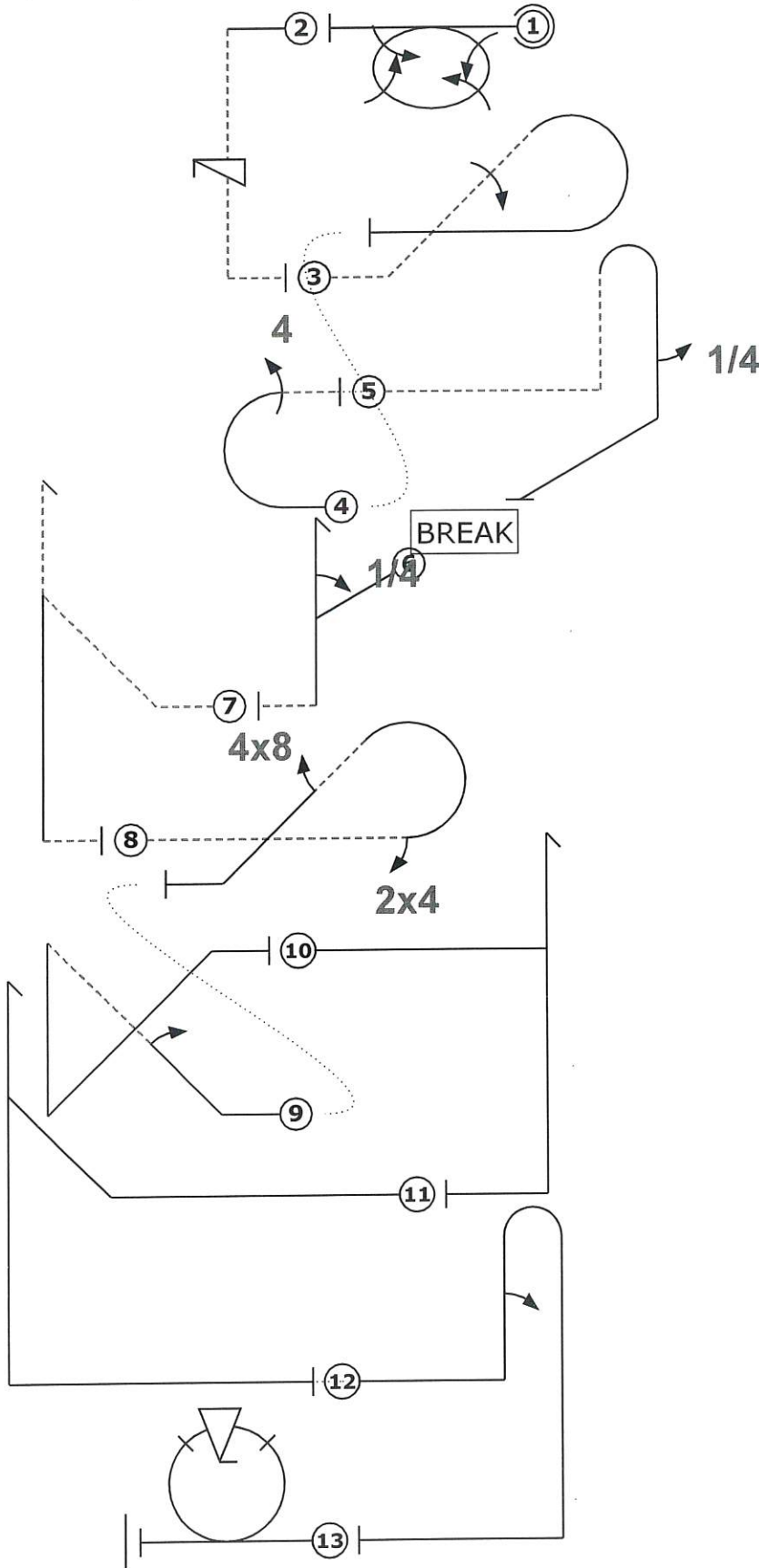

Avion		
Fig	Aresti	K
1	2.4.7.1	18 18
2	1.1.7.3 9.11.1.4	11 5 16
3	8.5.1.2 9.1.2.4	10 10 20
4	7.2.1.1 9.4.3.4	6 11 17
5	8.4.4.2 9.1.5.1	14 2 16
6	5.2.1.3 9.1.1.1	18 6 24
7	5.3.1.2	25 25
8	8.5.8.2 9.4.3.2 9.8.4.2	11 5 7 23
9	1.3.2.1 9.1.2.2	18 6 24
10	5.2.1.1	17 17
11	5.3.1.1	18 18
12	8.4.1.1 9.1.1.2	13 8 21
13	7.4.1.1 9.9.3.4	10 11 21
<b>Total K = 260</b> (max K = 260)		
Le K Aresti normal de la figure 1 a été changé selon le règlement 2022 france national_2 libre		

Pilote ID

France National\_2 libre

Vol N°

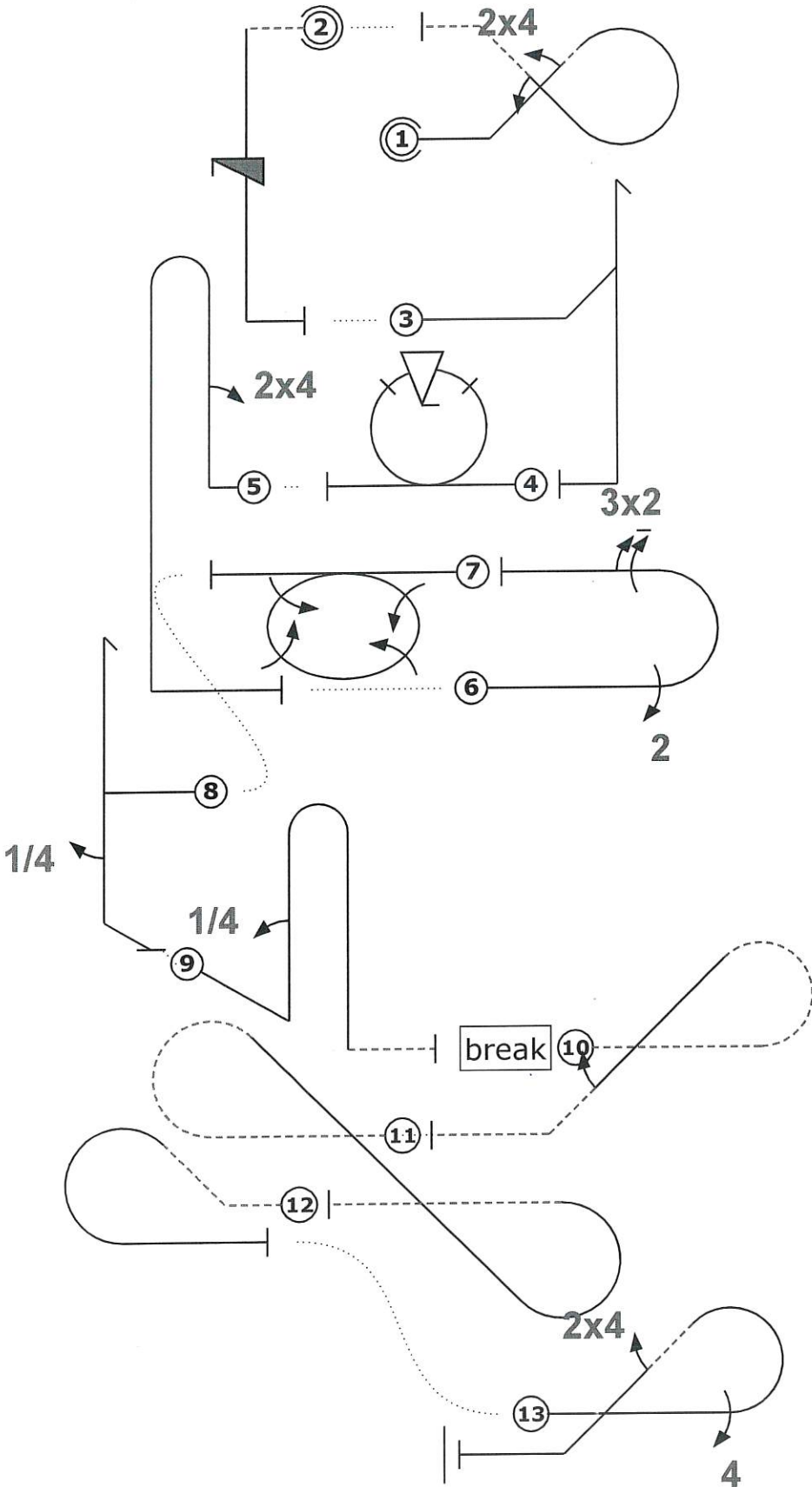

Avion			
Fig	Aresti	K	
1	7.3.4.1	16	29
	9.4.2.2	7	
	9.1.2.2	6	
2	1.1.7.4	9	16
	9.12.1.4	7	
3	5.3.1.1	18	18
4	7.4.1.1	10	21
	9.9.3.4	11	
5	8.4.1.1	13	22
	9.4.1.2	9	
6	7.2.2.1	6	27
	9.2.3.4	9	
	9.2.3.6	12	
7	2.4.7.1	18	18
8	5.2.1.1	17	19
	9.1.5.1	2	
9	8.4.2.1	14	20
	9.1.1.1	6	
10	8.5.6.2	14	18
	9.1.4.2	4	
11	7.5.1.2	16	16
12	8.5.1.2	10	10
13	8.5.6.1	10	26
	9.4.3.4	11	
	9.4.4.2	5	
<b>Total K = 260</b> (max K = 260)			
Le K Aresti normal de la figure 7 a été changé selon le règlement 2022 france national_2 libre			

*Delbreil*  
Cap 10 F-GGYL  
Pilote  
Avion

Pilote ID		Form C
France National_2 libre		Vol N°

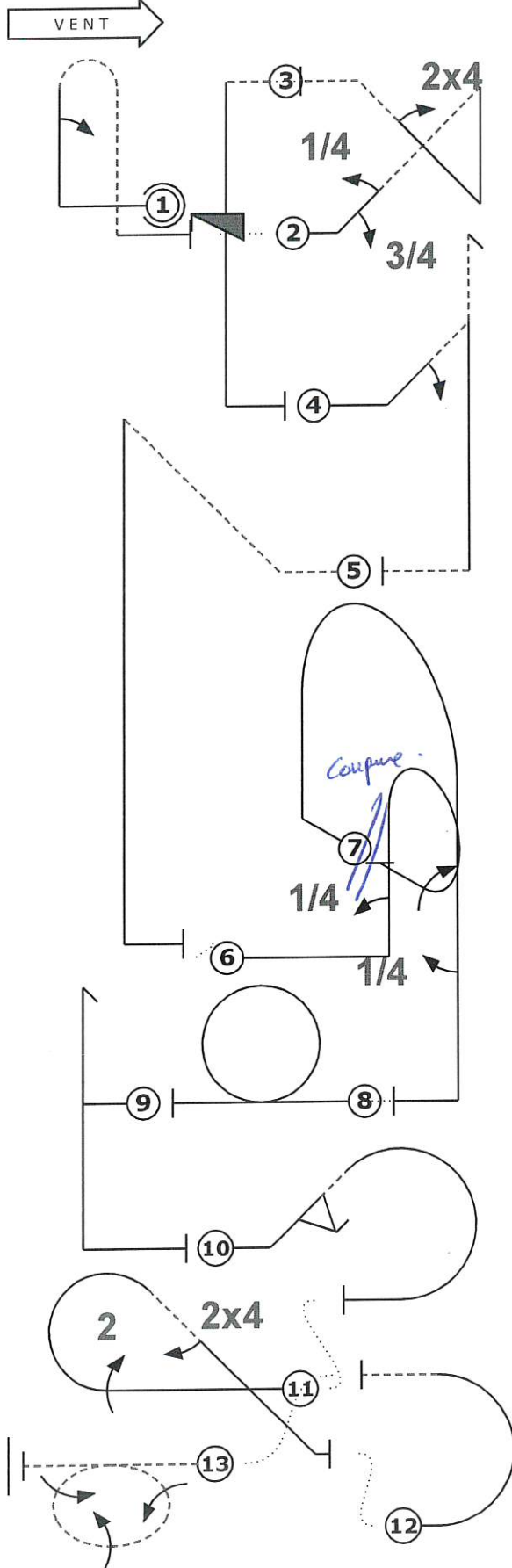

Avion			
Fig	Aresti	K	
1	8.4.3.1	15	23
	9.1.1.2	8	
2	1.3.4.1	18	37
	9.1.2.3	8	
	9.1.2.1	4	
	9.4.2.2	7	
3	1.1.7.4	9	16
	9.12.1.4	7	
4	5.3.2.3	25	31
	9.1.2.2	6	
5	1.2.2.2	13	13
6	8.6.1.1	11	25
	9.1.1.1	6	
	9.1.3.4	8	
7	8.4.1.1	13	15
	9.1.5.1	2	
8	7.4.1.1	10	10
9	5.2.1.1	17	17
10	8.5.2.1	10	23
	9.9.2.2	13	
11	8.5.6.1	10	24
	9.2.3.4	9	
	9.4.4.2	5	
12	7.2.1.1	6	6
13	2.4.5.2	20	20
<b>Total K = 260</b> (max K = 260)			
Le K Aresti normal de la figure 13 a été changé selon le règlement 2022 france national_2 libre			

*Clar*  
Pilote  
CR100 F-PLUS  
Avion  
*Coupsure ?*



Pilote ID

France National\_2 libre

Vol N°

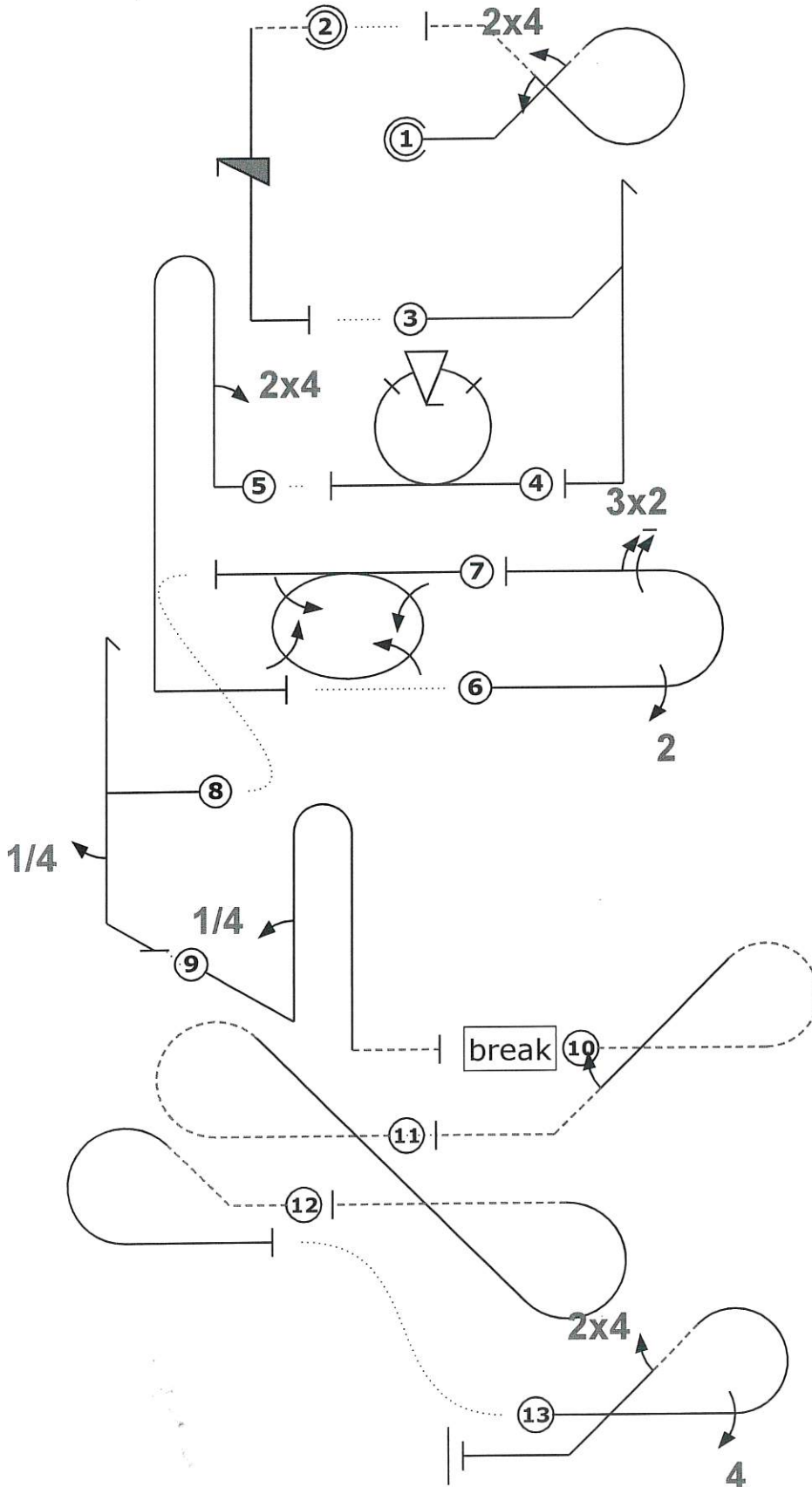

**Avion**

Fig	Aresti	K	
1	7.3.4.1	16	29
	9.4.2.2	7	
	9.1.2.2	6	
2	1.1.7.4	9	16
	9.12.1.4	7	
3	5.3.1.1	18	18
4	7.4.1.1	10	21
	9.9.3.4	11	
5	8.4.1.1	13	22
	9.4.1.2	9	
6	7.2.2.1	6	27
	9.2.3.4	9	
	9.2.3.6	12	
7	2.4.7.1	18	18
8	5.2.1.1	17	19
	9.1.5.1	2	
9	8.4.2.1	14	20
10	8.5.6.2	14	18
	9.1.4.2	4	
11	7.5.1.2	16	16
12	8.5.1.2	10	10
13	8.5.6.1	10	26
	9.4.3.4	11	
	9.4.4.2	5	

**Total K = 260**  
(max K = 260)

Le K Aresti normal de la figure 7 a été changé selon le règlement 2022 france national\_2 libre

Cano Pilote  
Cap 10 F-GGYL  
Avion

Pilote ID

France National\_2 libre

Vol N°

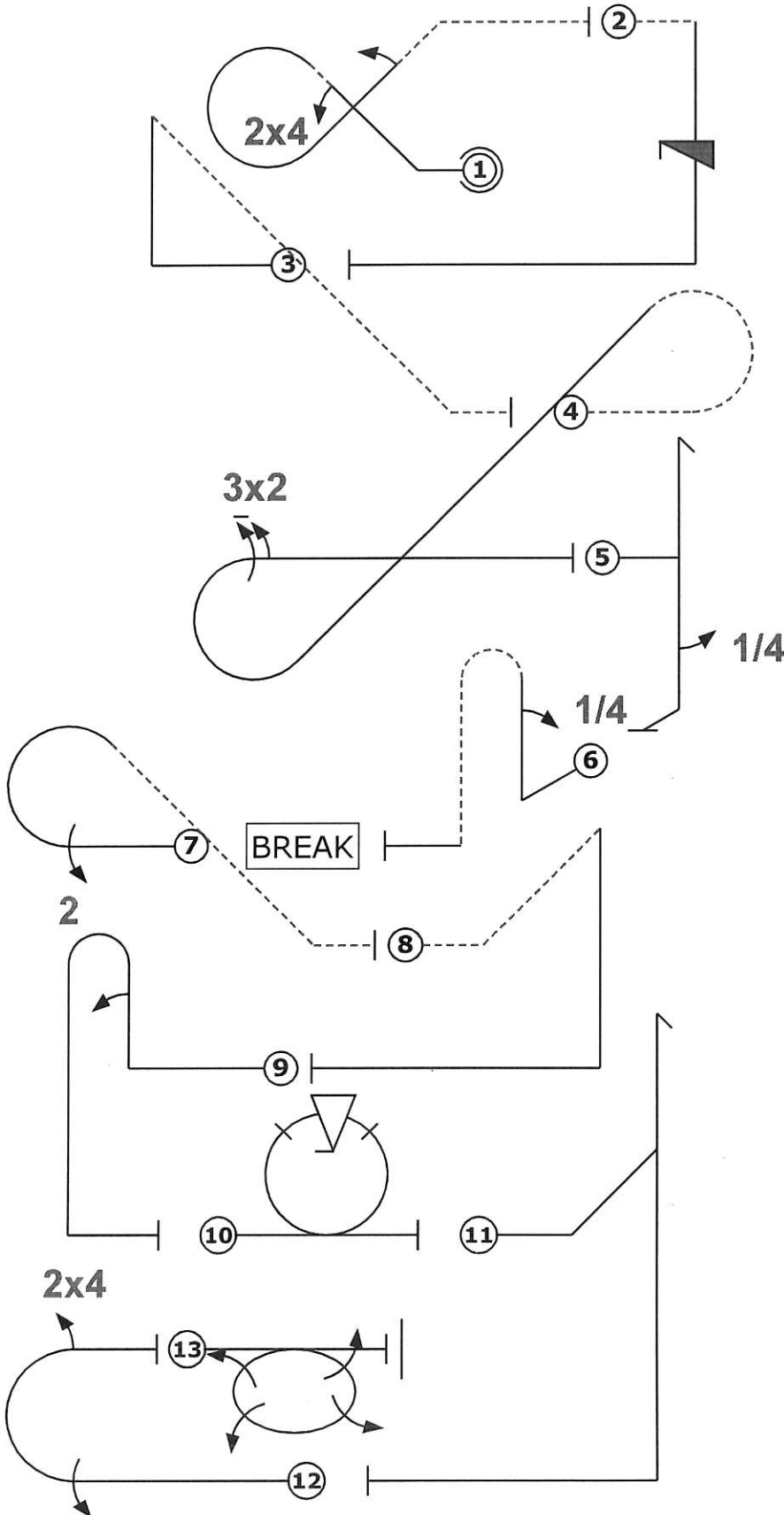

Avion			
Fig	Aresti	K	
1	7.3.4.1	16	29
	9.4.2.2	7	
	9.1.2.2	6	
2	1.1.7.4	9	16
	9.12.1.4	7	
3	1.2.5.1	14	14
4	7.5.4.2	16	28
	9.2.3.6	12	
5	5.2.1.1	17	19
	9.1.5.1	2	
6	8.4.3.1	15	21
	9.1.1.1	6	
7	8.5.5.1	10	19
	9.2.3.4	9	
8	1.2.2.2	13	13
9	8.4.1.1	13	21
	9.1.1.2	8	
10	7.4.1.1	10	21
	9.9.3.4	11	
11	5.3.1.1	18	18
12	7.2.2.1	6	19
	9.1.3.4	8	
	9.4.3.2	5	
13	2.4.7.3	22	22
<b>Total K = 260</b> (max K = 260)			
Le K Aresti normal de la figure 13 a été changé selon le règlement 2022 france national_2 libre			

Florent Cachera  
Pilote  
CAP-10C F-PCAP  
Avion

		Form B
Pilote ID	France National_2 libre	Vol N°

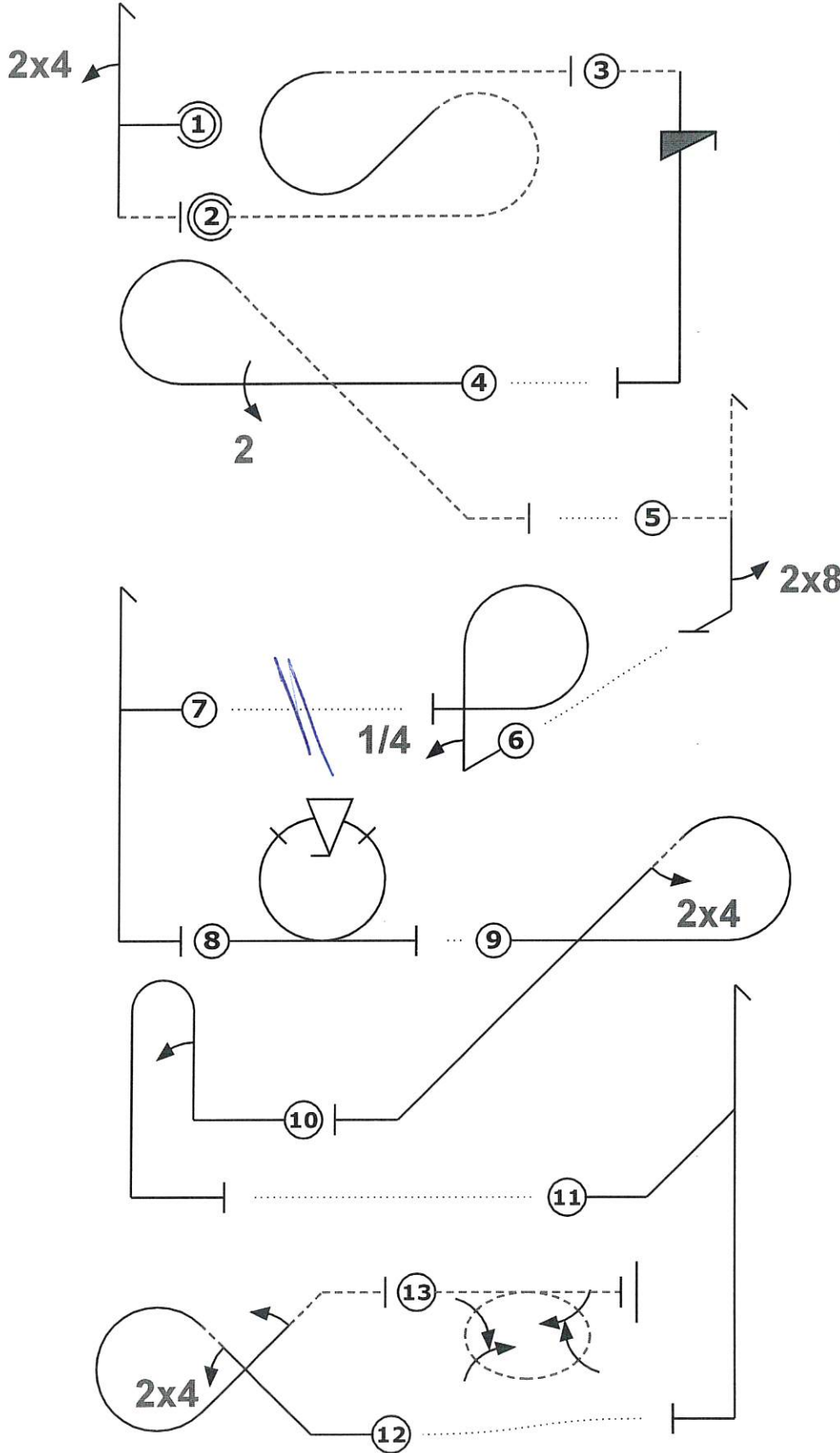

Avion			
Fig	Aresti	K	
1	5.2.1.3	18	27
	9.4.1.2	9	
2	7.5.1.2	16	16
3	1.1.7.4	9	16
	9.12.1.4	7	
4	8.5.5.1	10	19
	9.2.3.4	9	
5	5.2.1.4	22	25
	9.8.5.1	3	
6	8.6.1.1	11	17
	9.1.1.1	6	
7	5.2.1.1	17	17
8	7.4.1.1	10	21
	9.9.3.4	11	
9	8.5.6.1	10	15
	9.4.4.2	5	
10	8.4.1.1	13	21
	9.1.1.2	8	
11	5.3.1.1	18	18
12	7.3.4.1	16	29
	9.4.2.2	7	
	9.1.2.2	6	
13	2.4.7.2	19	19

**Total K = 260**  
(max K = 260)

Le K Aresti normal de la figure 13 a été changé selon le règlement 2022 france national\_2 libre

*BAS*  
Boulme Pilote  
Coupure Avion

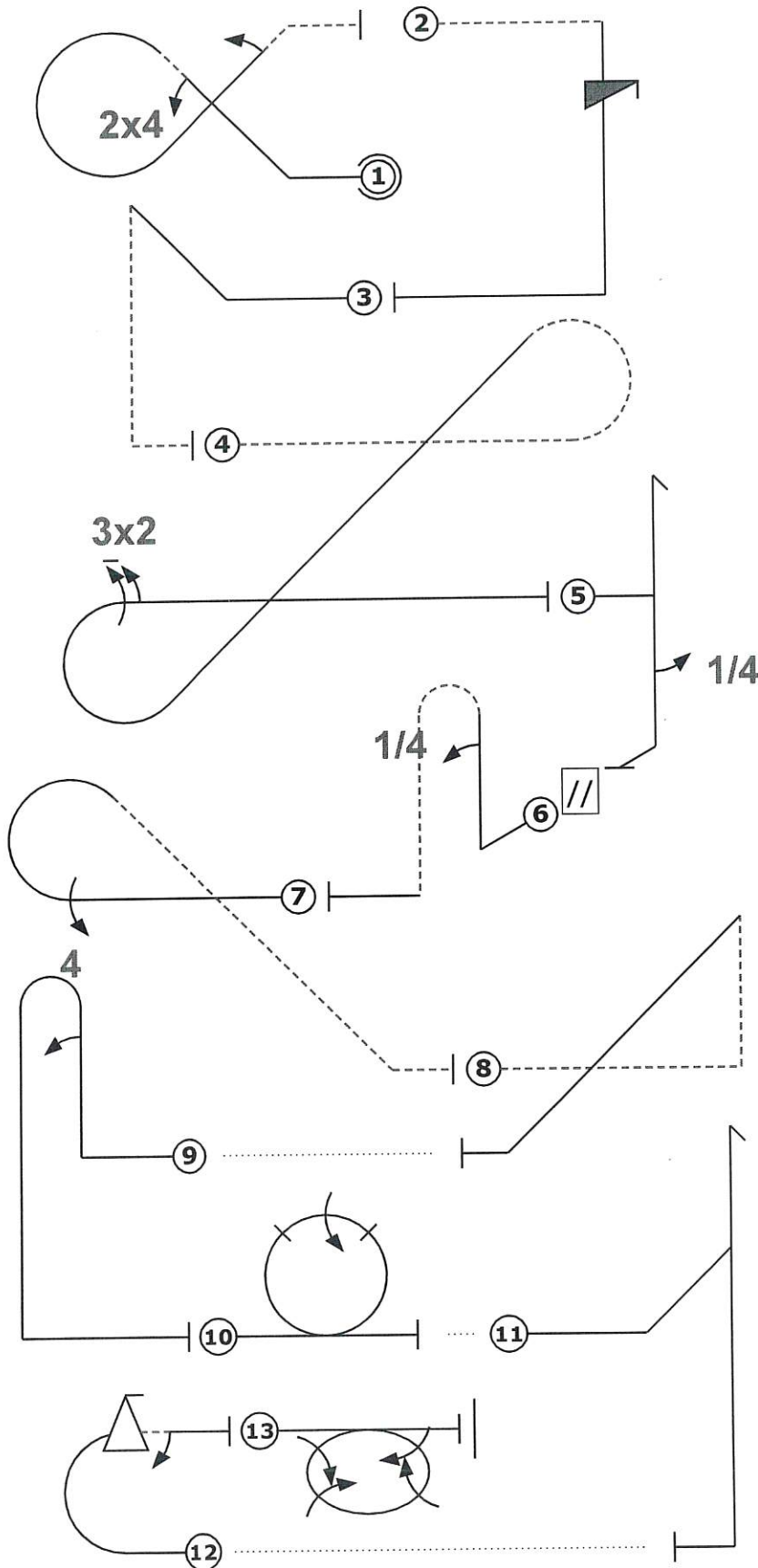

<b>Avion</b>			
Fig	Aresti	K	
1	7.3.4.1	16	29
	9.4.2.2	7	
	9.1.2.2	6	
2	1.1.7.4	9	16
	9.12.1.4	7	
3	1.2.2.1	14	14
4	7.5.4.2	16	28
	9.2.3.6	12	
5	5.2.1.1	17	19
	9.1.5.1	2	
6	8.4.3.1	15	21
	9.1.1.1	6	
7	8.5.5.1	10	21
	9.4.3.4	11	
8	1.2.5.2	16	16
9	8.4.1.1	13	21
	9.1.1.2	8	
10	7.4.1.1	10	18
	9.1.3.4	8	
11	5.3.1.1	18	18
12	7.2.2.1	6	21
	9.9.3.4	11	
	9.1.3.2	4	
13	2.4.7.1	18	18

**Total K = 260**  
(max K = 260)

Le K Aresti normal de la figure 13 a été changé selon le règlement 2022 france national\_2 libre

BERGER

CR100 FP1US

Pilote  
Avion