

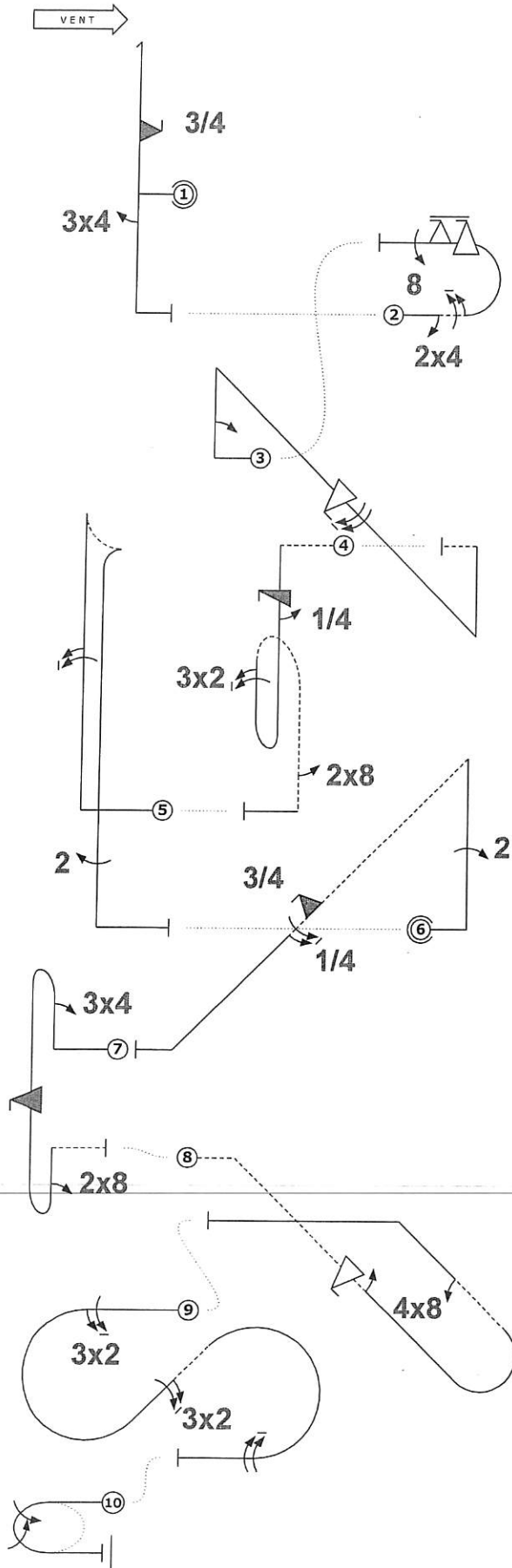

FAI

AEROBATICS
COMMISSION

		Form C
Pilote ID	CIVA Unlimited Free Known	Vol N°



Avion			
Fig	Aresti	K	
1	5.2.1.1	17	44
	9.10.6.3	19	
	9.4.5.3	8	
2	7.2.2.1	6	50
	9.4.3.2	5	
	8.1.3.6	10	
	9.9.3.6	14	
	9.8.3.4	15	
3	1.3.14.1	22	53
	9.1.1.2	8	
	9.9.4.4	11	
	9.1.4.8	12	
4	8.8.3.4	20	49
	9.12.1.4	7	
	9.1.5.1	2	
	9.2.1.6	17	
	9.8.5.1	3	
5	6.2.2.1	15	39
	9.1.1.6	15	
	9.2.5.4	9	
6	1.2.7.1	13	48
	9.2.1.4	13	
	9.10.4.3	13	
	9.1.4.5	9	
7	8.8.1.1	18	52
	9.4.1.3	12	
	9.10.10.4	15	
	9.8.1.1	7	
8	8.4.16.4	14	40
	9.9.9.4	13	
	9.1.4.2	4	
	9.8.2.2	9	
9	7.5.5.3	15	53
	9.2.3.6	12	
	9.2.2.6	14	
	9.1.3.8	12	
10	2.2.5.1	22	22
Total K = 450 (max K = 450)			

ODDON Pilote
 Extra 330 F-TGCI
 Avion



		Form C
Pilote ID	CIVA Unlimited Free Known	Vol N°

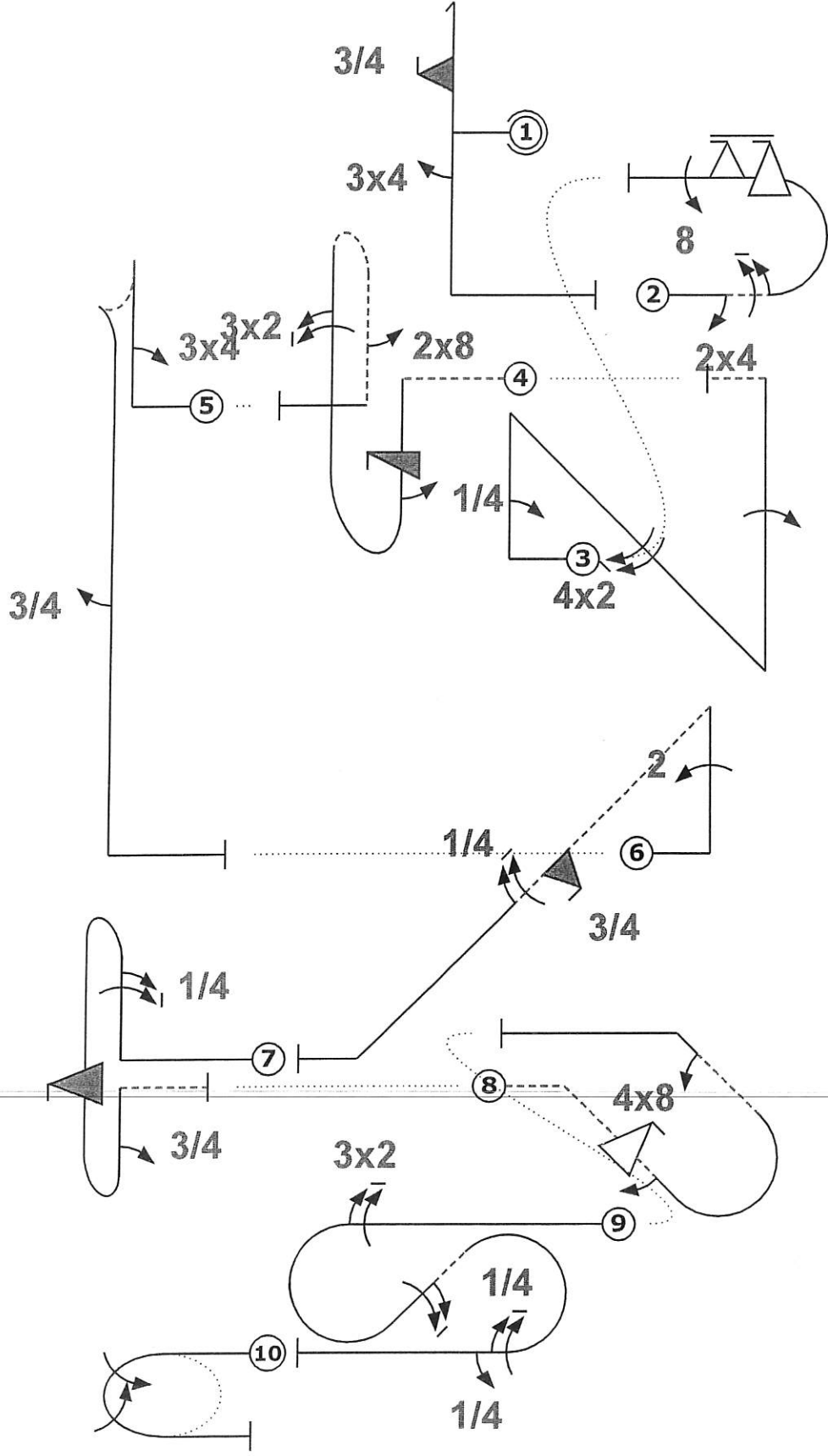

Avion			
Fig	Aresti	K	
1 A	5.2.1.1	17	44
	9.10.6.3	19	
	9.4.5.3	8	
2 B	7.2.2.1	6	50
	9.4.3.2	5	
	9.1.3.6	10	
	9.9.3.6	14	
	9.8.3.4	15	
3	1.3.14.1	22	57
	9.1.1.2	8	
	9.2.4.8	15	
	9.1.1.4	12	
4 E	8.8.3.4	20	49
	9.12.1.4	7	
	9.1.5.1	2	
	9.2.1.6	17	
	9.8.5.1	3	
5	6.2.2.1	15	33
	9.4.1.3	12	
	9.1.5.3	6	
6 D	1.2.7.1	13	48
	9.2.1.4	13	
	9.10.4.3	13	
	9.1.4.5	9	
7	8.8.1.1	18	57
	9.1.1.5	14	
	9.10.10.4	15	
	9.1.1.3	10	
8 C	8.4.16.4	14	40
	9.9.9.4	13	
	9.1.4.2	4	
	9.8.2.2	9	
9	7.5.5.3	15	50
	9.2.3.6	12	
	9.1.2.6	12	
	9.1.3.5	9	
	9.1.3.1	2	
10	2.2.5.1	22	22
Total K = 450 (max K = 450)			

LALLOUE Pilote
 EXTRA330SC FTGCI Avion



CIVA Unlimited

Free Known

Figure K

450

K total

490

Nom des Juges		Vol N°
Signature	Numéro	

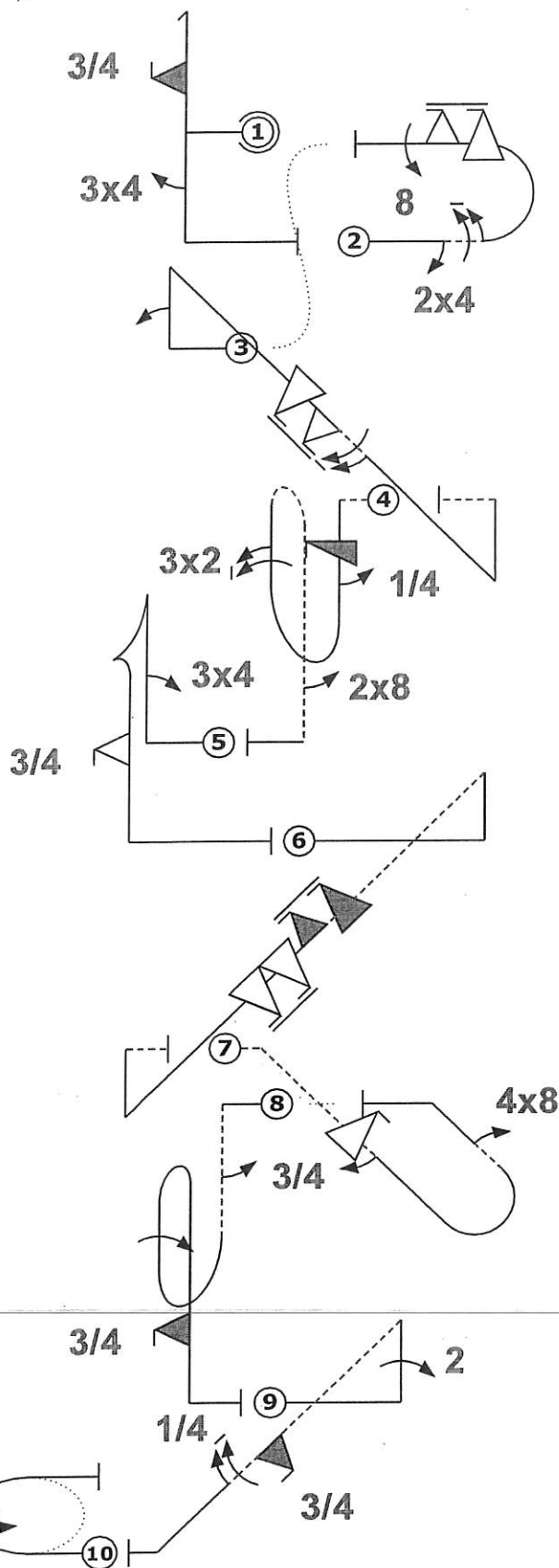

Fig	Grade	Pos	Remarks
1	.		
2	.		
3	.		
4	.		
5	.		
6	.		
7	.		
8	.		
9	.		
10	.		

Cadre(Coef)

40

Trop Bas		Echauf. non OK	
Trop Haut		Battem. d'Ailes	
Interruptions		Disqualifié	
Insertions		Autre(noter...)	

Fig 1 A	K	Fig 2 B	K	Fig 3	K	Fig 4 E	K	Fig 5	K	Fig 6	K	Fig 7 C	K	Fig 8	K	Fig 9 D	K	Fig 10	K
5.2.1.1	17	7.2.2.1	6	1.3.14.1	22	8.8.3.4	20	6.2.1.1	15	1.3.11.1	20	8.4.16.4	14	8.8.8.3	19	1.2.7.1	13	2.2.5.1	22
9.10.6.3	19	9.4.3.2	5	9.1.1.2	8	9.12.1.4	7	9.4.1.3	12	9.10.4.6	16	9.9.9.4	13	9.1.5.3	6	9.2.1.4	13		
9.4.5.3	8	9.1.3.6	10	9.9.4.6	14	9.1.5.1	2	9.9.5.3	11	9.9.4.8	17	9.1.4.2	4	9.1.1.4	12	9.10.4.3	13		
		9.9.3.6	14	9.1.4.6	10	9.2.1.6	17					9.8.2.2	9	9.10.10.3	15	9.1.4.5	9		
		9.8.3.4	15			9.8.5.1	3												
	44		50		54		49		38		53		40		52		48		22

Pilote: Louis VANEL

Avion: E330SC FHMKF

Equipe: FRA



		Form C
Pilote ID	CIVA Unlimited Free Known	
	Vol N°	

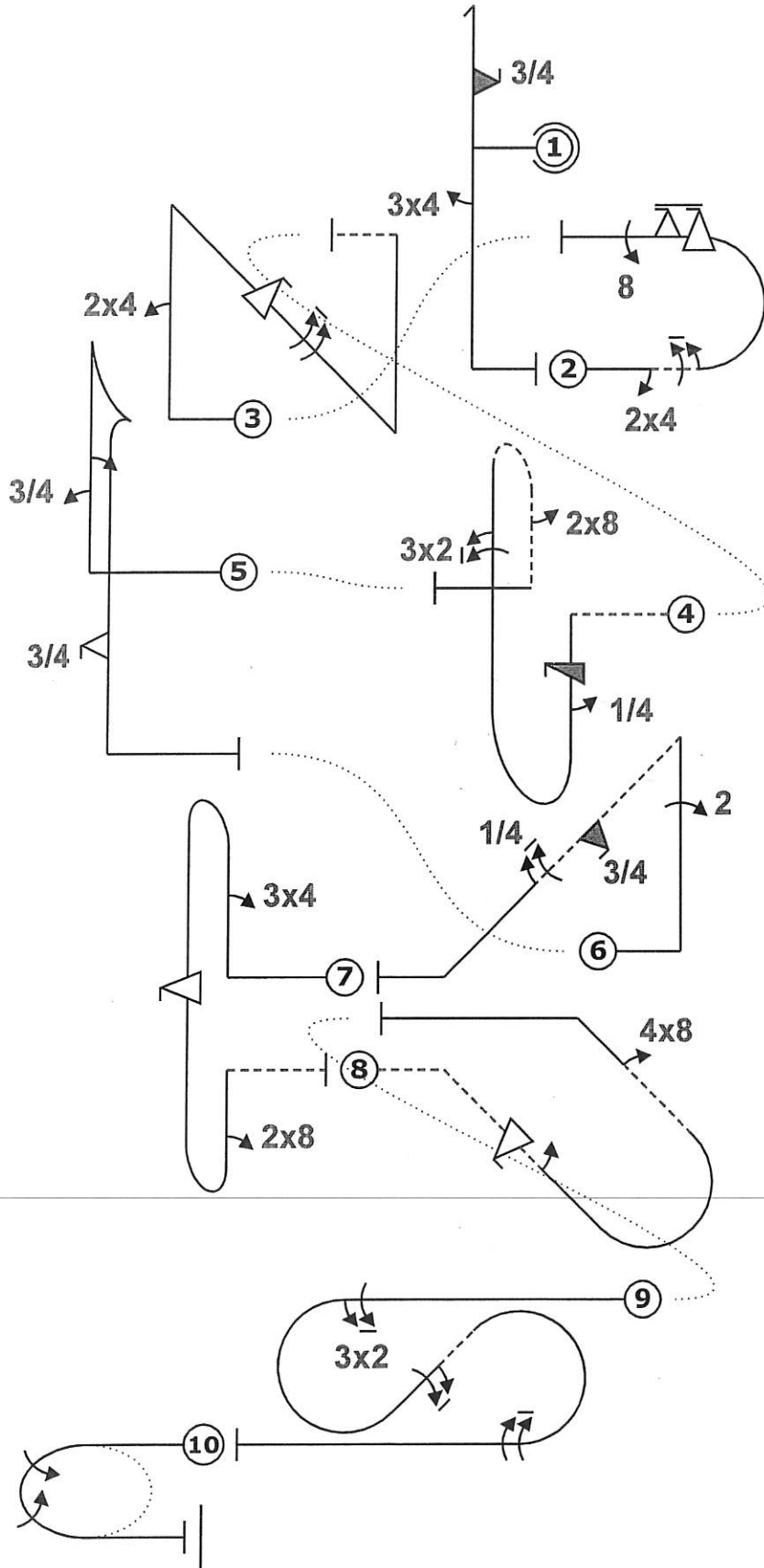

"@A" 3ifh34... "@B" 24,6m6f,88 (15,11) .,24pn(,f';9.)"- (-26,23) "@E" -"1s,4''1Bpb(,32),8> (8,-1) .,3,2'ta.'3F.' (-18,12) "@D" .22k,3if
,5 34''bb(f.'')8- "@C" -f,2.indb48'' (-20,17) ,321ac(6)9 2j2

DENIS Pilote
EXTRA 330 SC F-TGC Avion

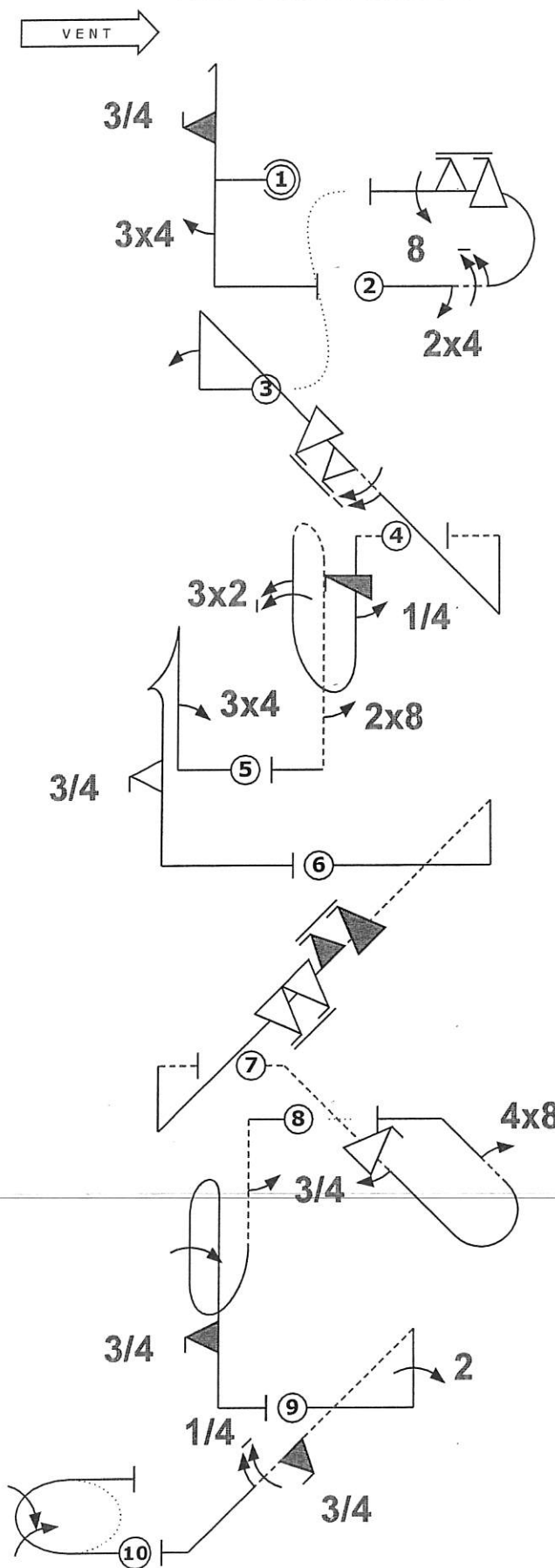

Avion			
Fig	Aresti	K	
1 A	5.2.1.1	17	44
	9.10.6.3	19	
	9.4.5.3	8	
2 B	7.2.2.1	6	50
	9.4.3.2	5	
	9.1.3.6	10	
	9.9.3.6	14	
	9.8.3.4	15	
3	1.3.14.1	22	54
	9.1.1.2	8	
	9.9.4.6	14	
	9.1.4.6	10	
4 E	8.8.3.4	20	49
	9.12.1.4	7	
	9.1.5.1	2	
	9.2.1.6	17	
	9.8.5.1	3	
5	6.2.1.1	15	38
	9.4.1.3	12	
	9.9.5.3	11	
6	1.3.11.1	20	53
	9.10.4.6	16	
	9.9.4.8	17	
7 C	8.4.16.4	14	40
	9.9.9.4	13	
	9.1.4.2	4	
	9.8.2.2	9	
8	8.8.8.3	19	52
	9.1.5.3	6	
	9.1.1.4	12	
	9.10.10.3	15	
9 D	1.2.7.1	13	48
	9.2.1.4	13	
	9.10.4.3	13	
	9.1.4.5	9	
10	2.2.5.1	22	22
Total K = 450		(max K = 450)	

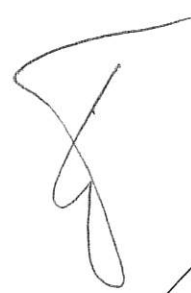
 CHESNEAU Fred
 Pilote
 SU 26
 Avion

Pilote ID

CIVA Unlimited Free Known

Vol N°

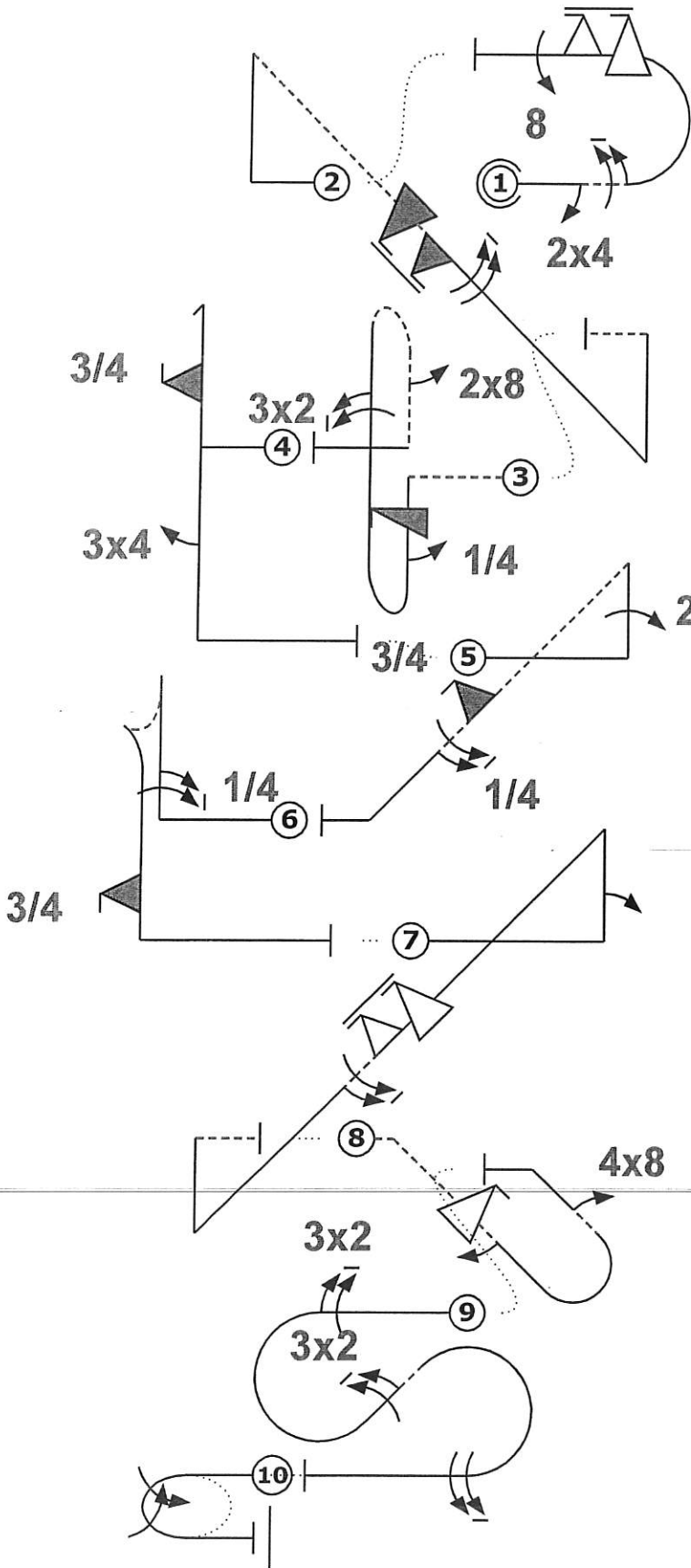

Avion			
Fig	Aresti	K	
1 B	7.2.2.1	6	50
	9.4.3.2	5	
	9.1.3.6	10	
	9.9.3.6	14	
	9.8.3.4	15	
2	1.3.11.1	20	48
	9.10.4.6	16	
	9.1.4.8	12	
3 E	8.8.3.4	20	49
	9.12.1.4	7	
	9.1.5.1	2	
	9.2.1.6	17	
	9.8.5.1	3	
4 A	5.2.1.1	17	44
	9.10.6.3	19	
	9.4.5.3	8	
5 D	1.2.7.1	13	48
	9.2.1.4	13	
	9.10.4.3	13	
	9.1.4.5	9	
6	6.2.2.1	15	42
	9.1.1.5	14	
	9.10.5.3	13	
7	1.3.14.1	22	54
	9.1.1.2	8	
	9.9.4.6	14	
	9.1.4.6	10	
8 C	8.4.16.4	14	40
	9.9.9.4	13	
	9.1.4.2	4	
	9.8.2.2	9	
9	7.5.5.3	15	53
	9.2.3.6	12	
	9.2.2.6	14	
	9.1.3.8	12	
10	2.2.5.1	22	22
Total K = 450 (max K = 450)			

Mika Brageot
 MIKA BRAGEOT Pilote
 EXTRA330SC F-HMKF
 Avion



		Form C
Pilot ID	CIVA Advanced Programme1	Flight #

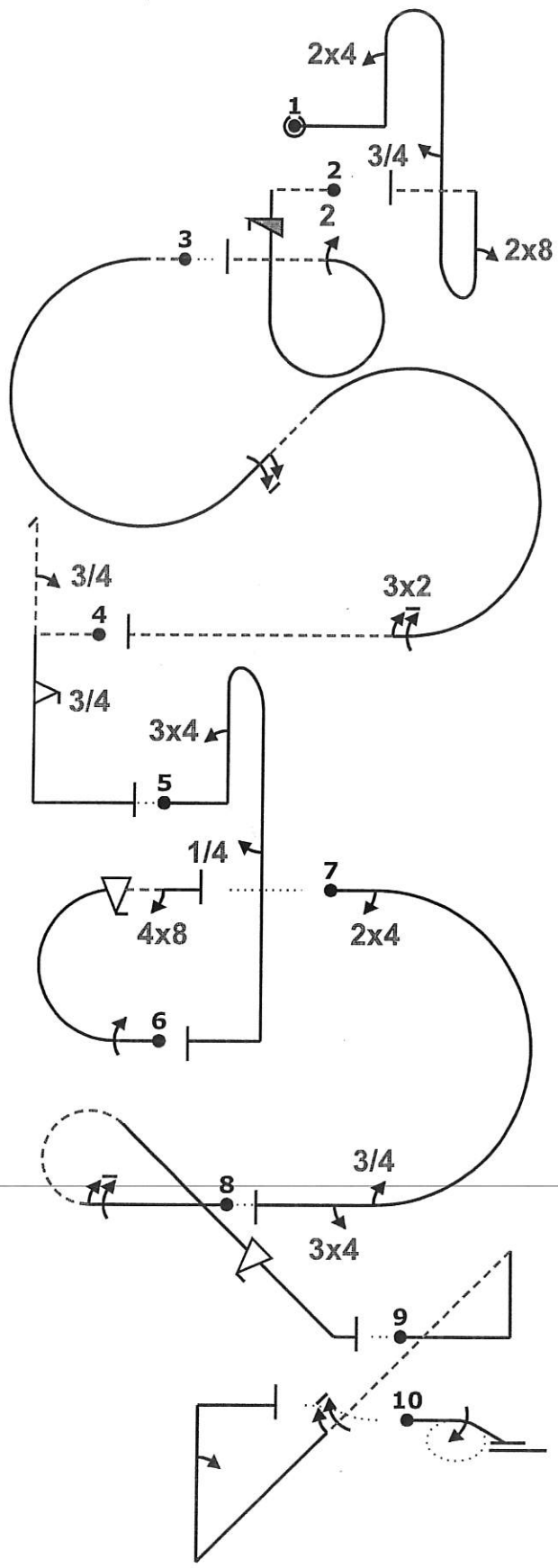

ed "@E" ,24bb("3.)8- (0,0) -isirp22-- (-1,0) 13%iac("6)32-....."@A" -3h,3f.''+ (2,0) "'+',34'b.'4...+' 3% "@D"
 "1mf;48+" (-5,0) "@B" 17% ""24a3,34+"" (-2,0) "@C" -2% ""6c....'f+"" (1,0) -4% ~+n(.....'6.....')...2''+~ (-5,1) -5% 1j1-

Chesneau paul
 Pilot
 Extra 330 F-HMKF
 A/C



LFCW		Form C
Pilote ID	CIVA Advanced Programme1	Vol N°

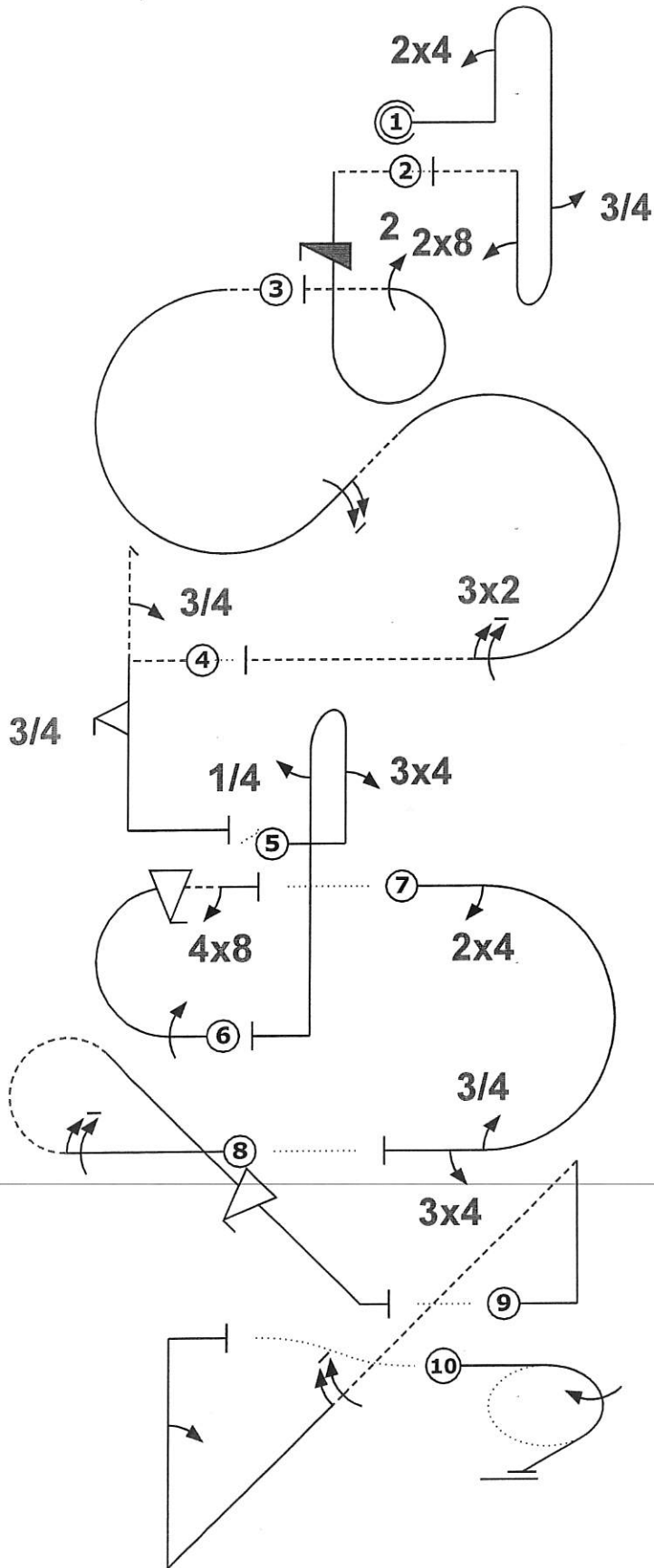

Avion			
Fig	Aresti	K	
1 E	8.8.1.1	18	40
	9.4.1.2	9	
	9.1.5.3	6	
	9.8.1.1	7	
2	8.6.1.4	12	28
	9.12.1.4	7	
	9.2.3.4	9	
3	7.5.7.4	15	39
	9.1.2.6	12	
	9.2.3.6	12	
4 A	5.2.1.4	22	43
	9.1.1.3	10	
	9.9.5.3	11	
5	8.4.1.1	13	27
	9.4.1.3	12	
	9.1.5.1	2	
6 D	7.2.2.1	6	32
	9.1.3.4	8	
	9.9.3.4	11	
	9.8.3.2	7	
7 B	7.2.3.3	6	25
	9.4.3.2	5	
	9.1.3.3	6	
	9.4.3.3	8	
8 C	8.5.7.1	12	33
	9.1.3.6	10	
	9.9.4.4	11	
9	1.3.12.1	21	39
	9.1.4.6	10	
	9.1.1.2	8	
	2.1.3.1	14	
Total K = 320		(max K = 320)	

 Maxime Orth
 Pilote
 EA330SC F-HMKF
 Avion



		Form C
Pilote ID	CIVA Advanced Free Known	Vol N°

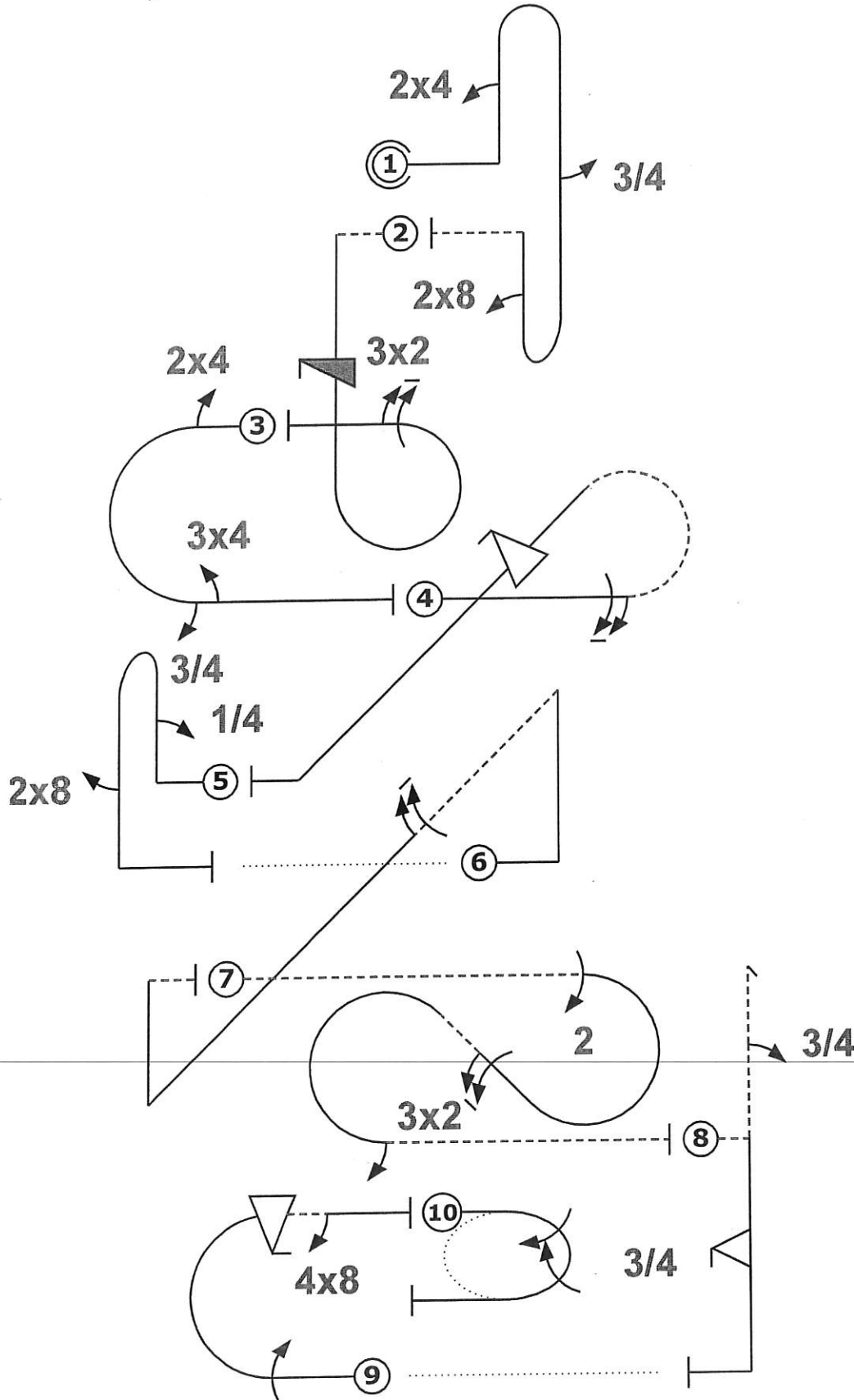

Avion			
Fig	Aresti	K	
1 E	8.8.1.1	18	40
	9.4.1.2	9	
	9.1.5.3	6	
	9.8.1.1	7	
2	8.6.2.4	12	31
	9.12.1.4	7	
	9.2.3.6	12	
3 B	7.2.3.3	6	25
	9.4.3.2	5	
	9.1.3.3	6	
	9.4.3.3	8	
4 C	8.5.7.1	12	33
	9.1.3.6	10	
	9.9.4.4	11	
5	8.4.1.1	13	22
	9.1.1.1	6	
	9.8.5.1	3	
6	1.3.11.1	20	30
	9.1.4.6	10	
7	7.5.7.4	15	42
	9.2.3.4	9	
	9.2.2.6	14	
	9.1.3.2	4	
8 A	5.2.1.4	22	43
	9.1.1.3	10	
	9.9.5.3	11	
9 D	7.2.2.1	6	32
	9.1.3.4	8	
	9.9.3.4	11	
	9.8.3.2	7	
10	2.2.5.1	22	22
Total K = 320 (max K = 320)			

ASB
Sébastien Bourdillon
Pilote
Cap 232 F-HKAP
Avion



		Form C
Pilote ID	CIVA Advanced Free Known	Vol N°

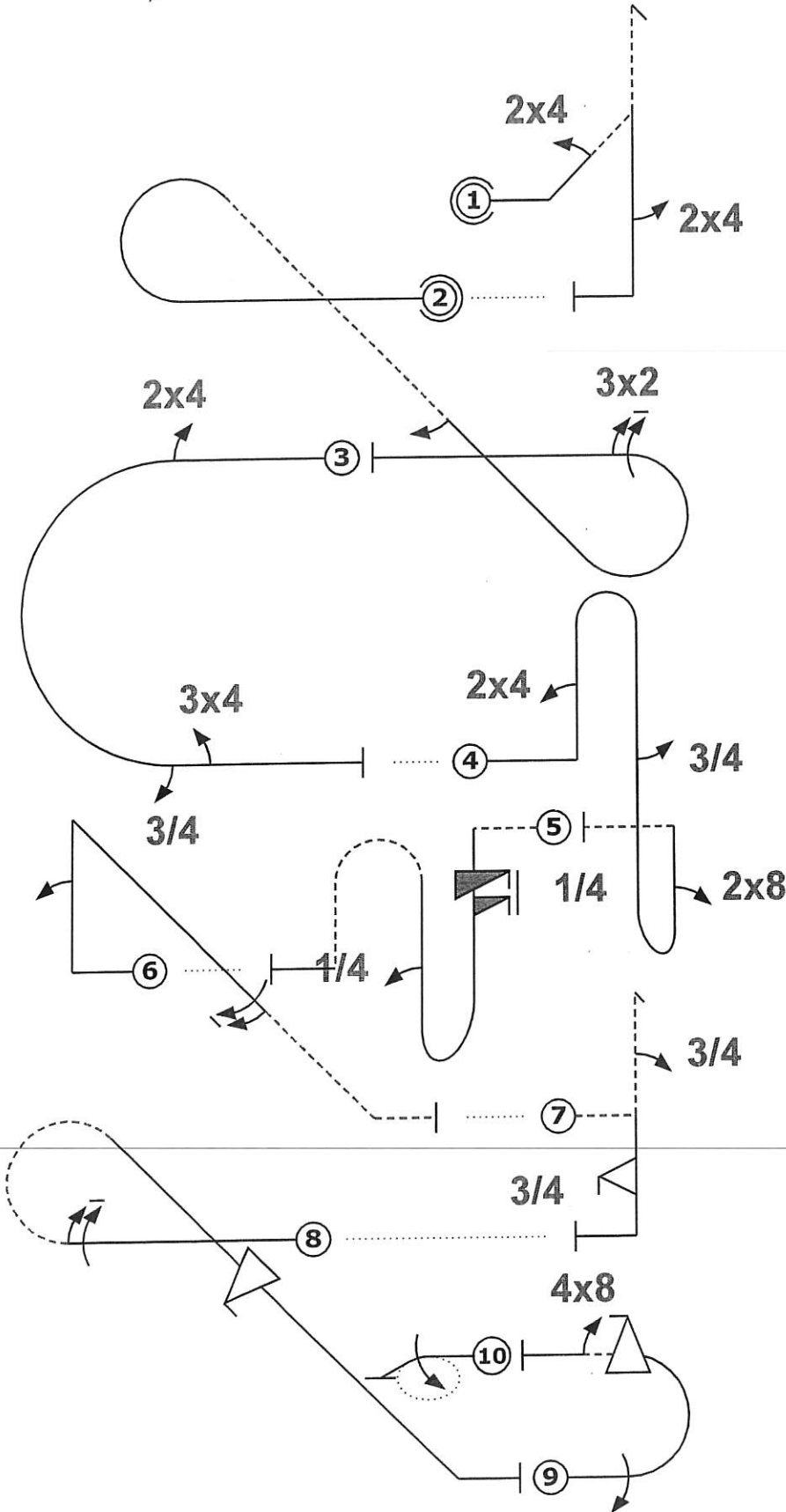

Avion			
Fig	Aresti	K	
1	5.3.2.1	24	36
	9.4.2.2	7	
	9.4.5.2	5	
2	7.5.7.1	15	31
	9.1.4.2	4	
	9.2.3.6	12	
3 B	7.2.3.3	6	25
	9.4.3.2	5	
	9.1.3.3	6	
	9.4.3.3	8	
4 E	8.8.1.1	18	40
	9.4.1.2	9	
	9.1.5.3	6	
	9.8.1.1	7	
5	8.8.3.4	20	32
	9.12.1.5	6	
	9.1.1.1	6	
6	1.2.8.1	16	34
	9.1.1.2	8	
	9.1.4.6	10	
7 A	5.2.1.4	22	43
	9.1.1.3	10	
	9.9.5.3	11	
8 C	8.5.7.1	12	33
	9.1.3.6	10	
	9.9.4.4	11	
9 D	7.2.2.1	6	32
	9.1.3.4	8	
	9.9.3.4	11	
	9.8.3.2	7	
10	2.1.3.1	14	14
Total K = 320 (max K = 320)			

Alber
 Mario Alberti Pilote
 CAP 232 F-HKAP Avion

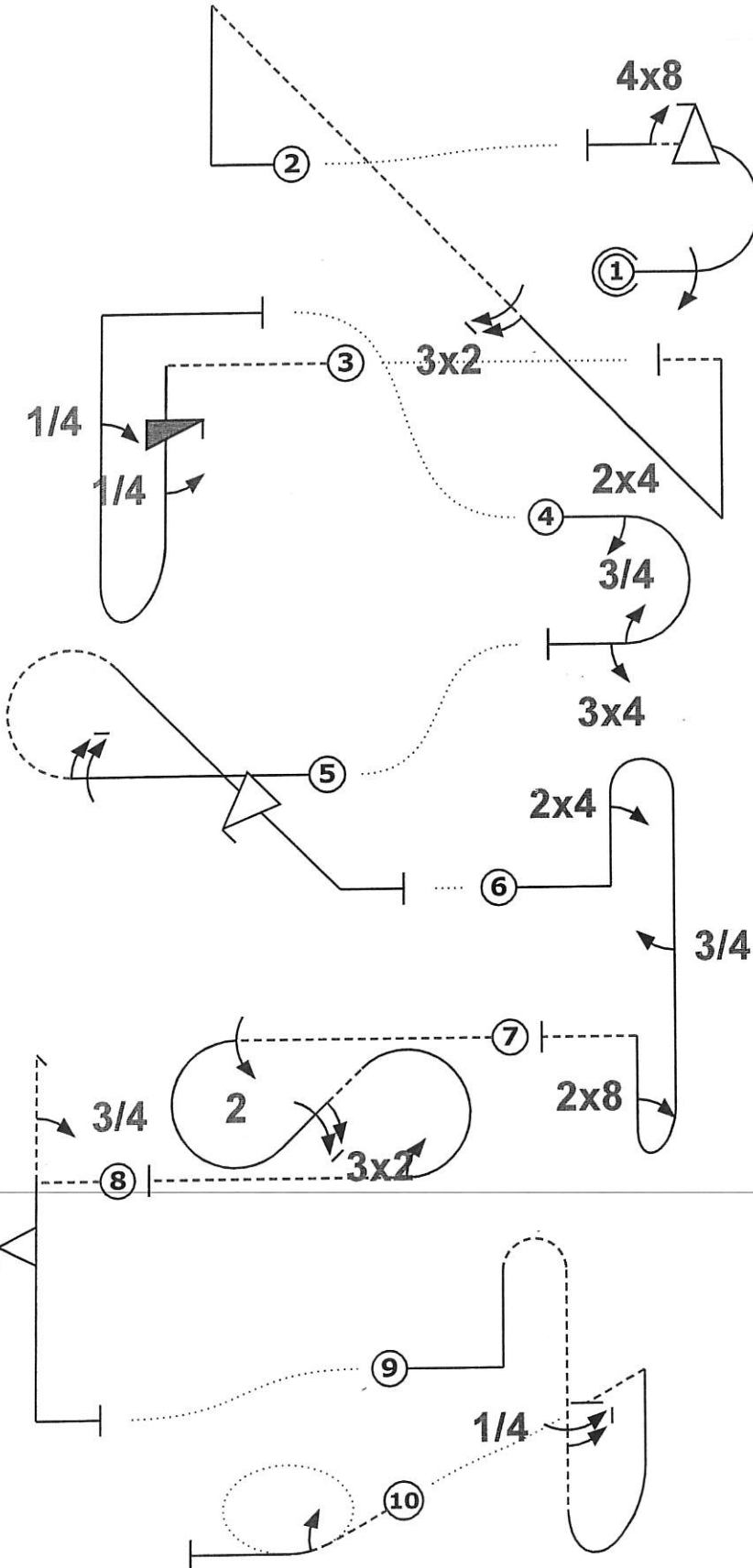

Avion			
Fig	Aresti	K	
1 D	7.2.2.1	6	32
	9.1.3.4	8	
	9.9.3.4	11	
	9.8.3.2	7	
2	1.3.11.1	20	32
	9.2.4.6	12	
3	8.4.2.4	14	29
	9.12.1.4	7	
	9.1.5.1	2	
	9.1.1.1	6	
4 B	7.2.3.3	6	25
	9.4.3.2	5	
	9.1.3.3	6	
	9.4.3.3	8	
5 C	8.5.7.1	12	33
	9.1.3.6	10	
	9.9.4.4	11	
6 E	8.8.1.1	18	40
	9.4.1.2	9	
	9.1.5.3	6	
	9.8.1.1	7	
7	7.5.7.4	15	42
	9.2.3.4	9	
	9.2.2.6	14	
	9.1.3.2	4	
8 A	5.2.1.4	22	43
	9.1.1.3	10	
	9.9.5.3	11	
9	8.8.5.1	21	30
	9.1.5.5	9	
10	2.1.2.2	14	14
Total K = 320		(max K = 320)	

FAYARD BORIS
 Pilote
ARS 300 F-PDCF
 Avion