

Pilot ID

France Advanced inconnu-libre 2

Flight #

A

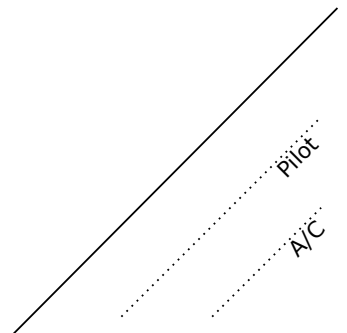
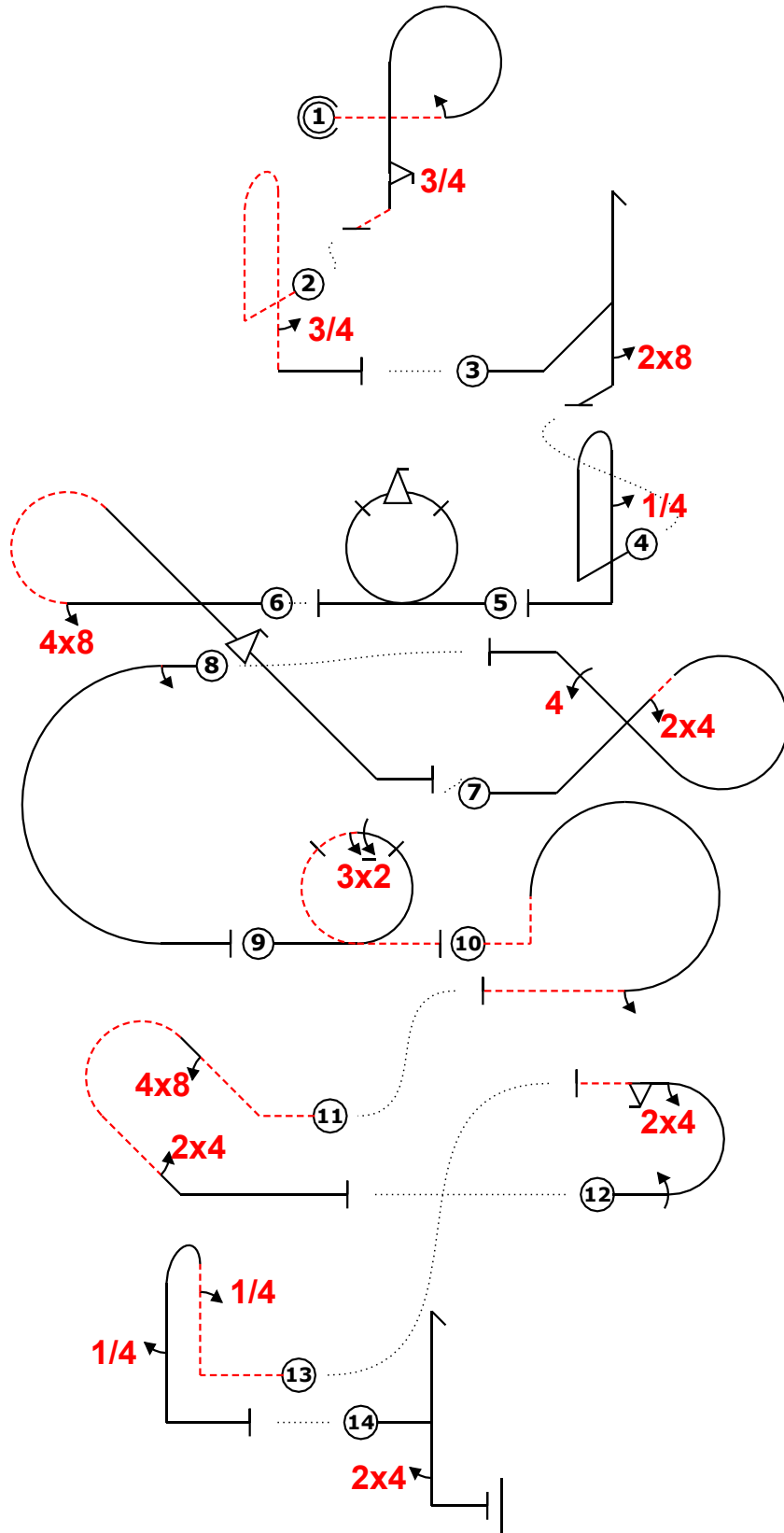
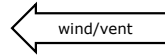

Pilot ID

Flight #

France Advanced inconnu-libre 2

A

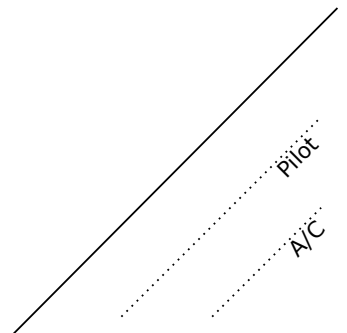
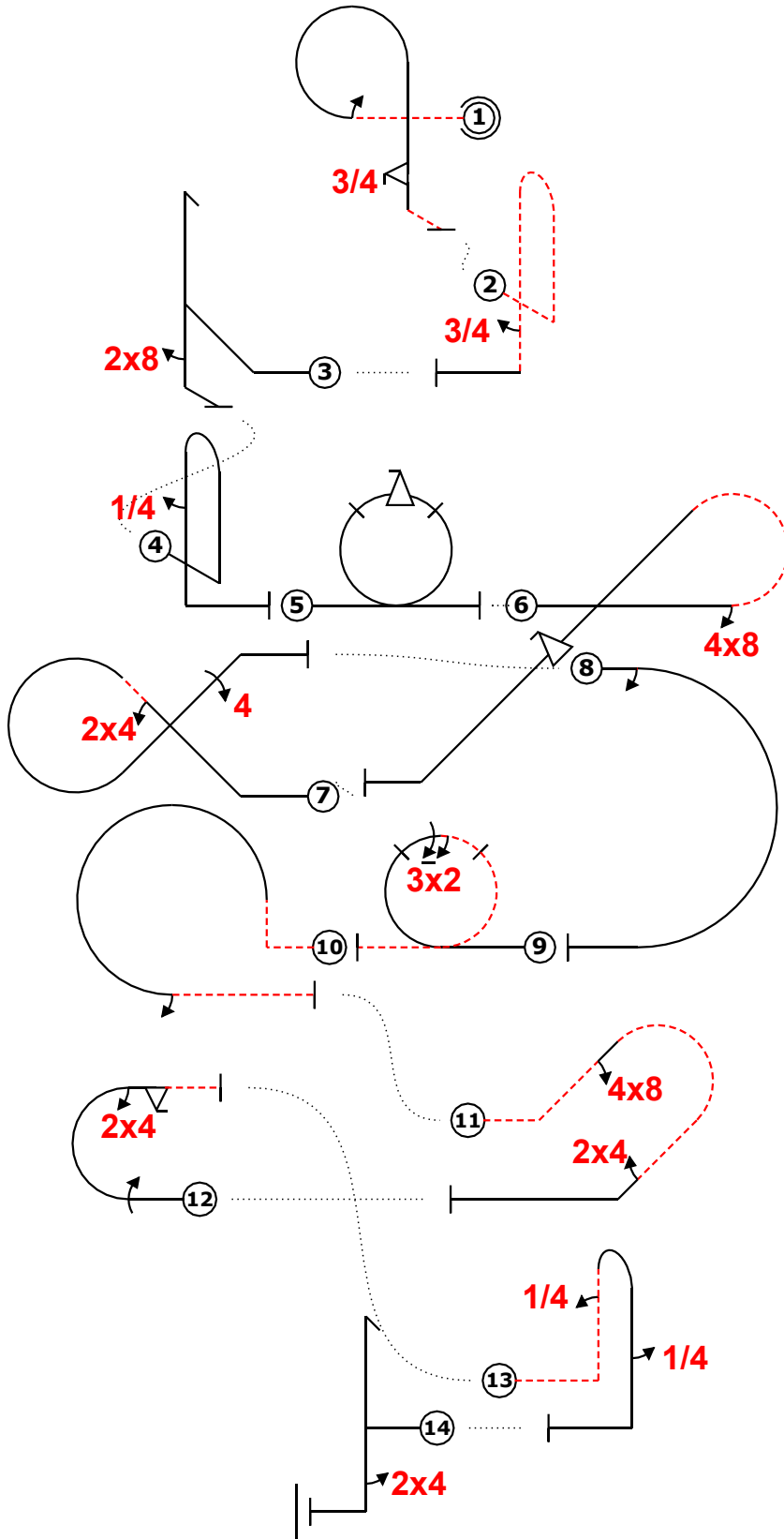
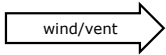

Pilot ID

France Advanced inconnu-libre 2

Flight #

6

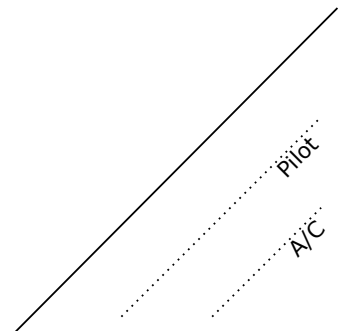
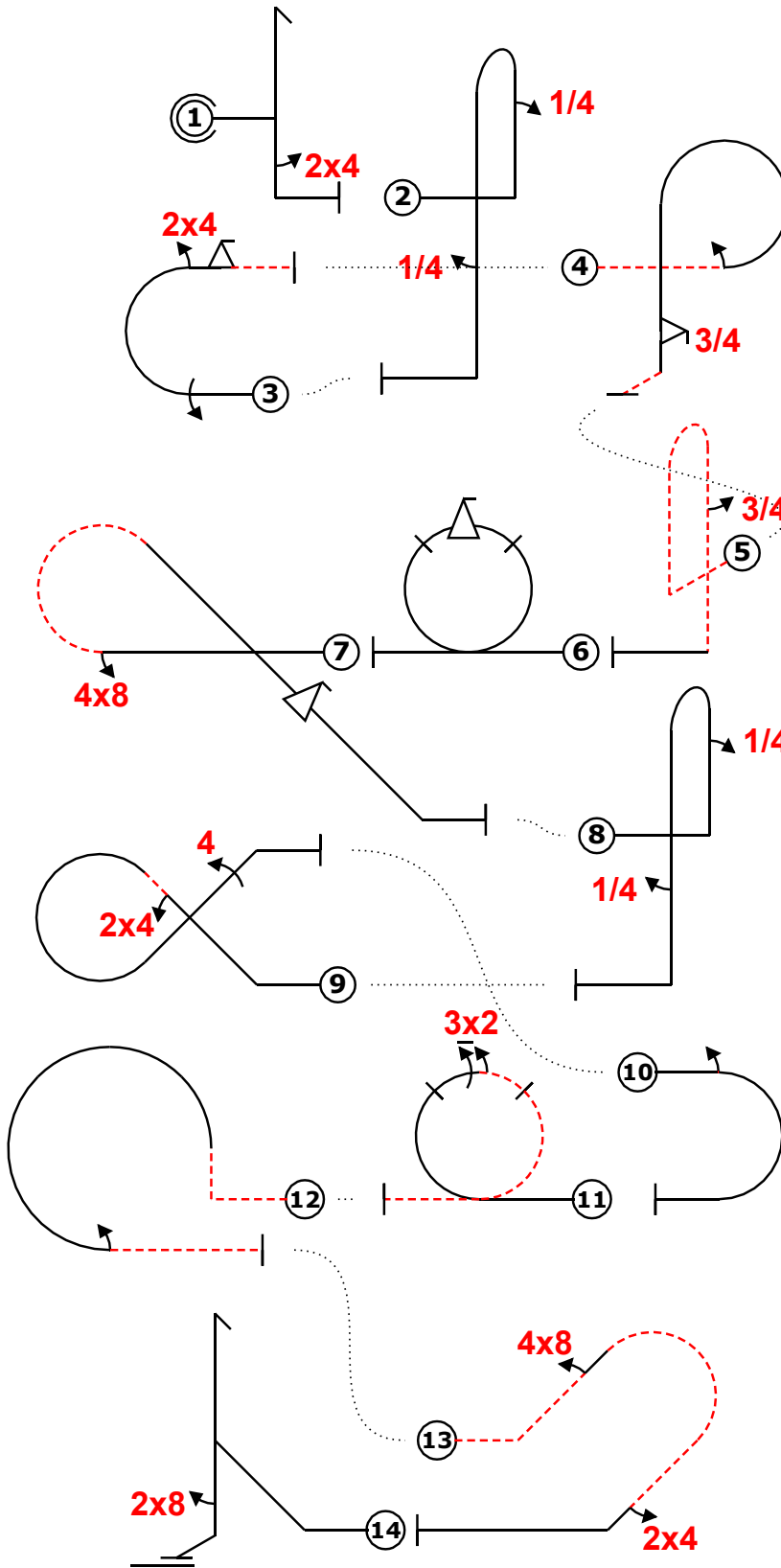
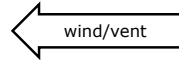

Pilot ID

France Advanced inconnu-libre 2

Flight #

B

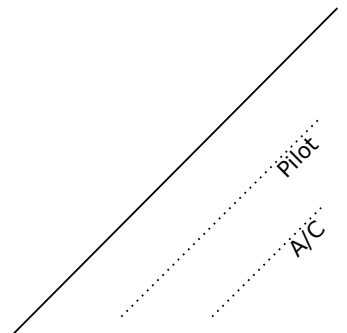
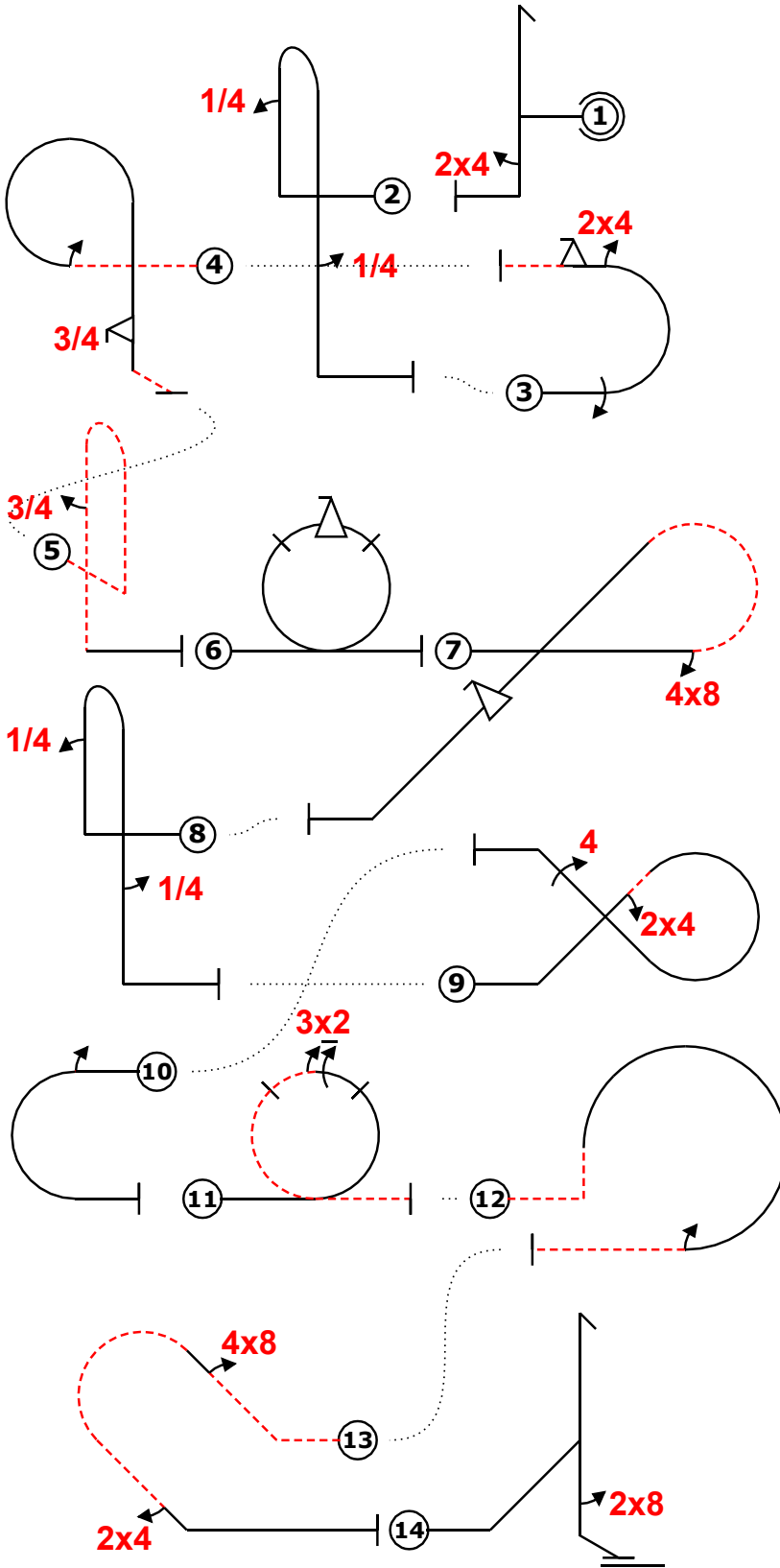
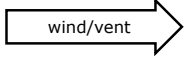

Pilot ID

France Advanced inconnu-libre 2

Flight #

C

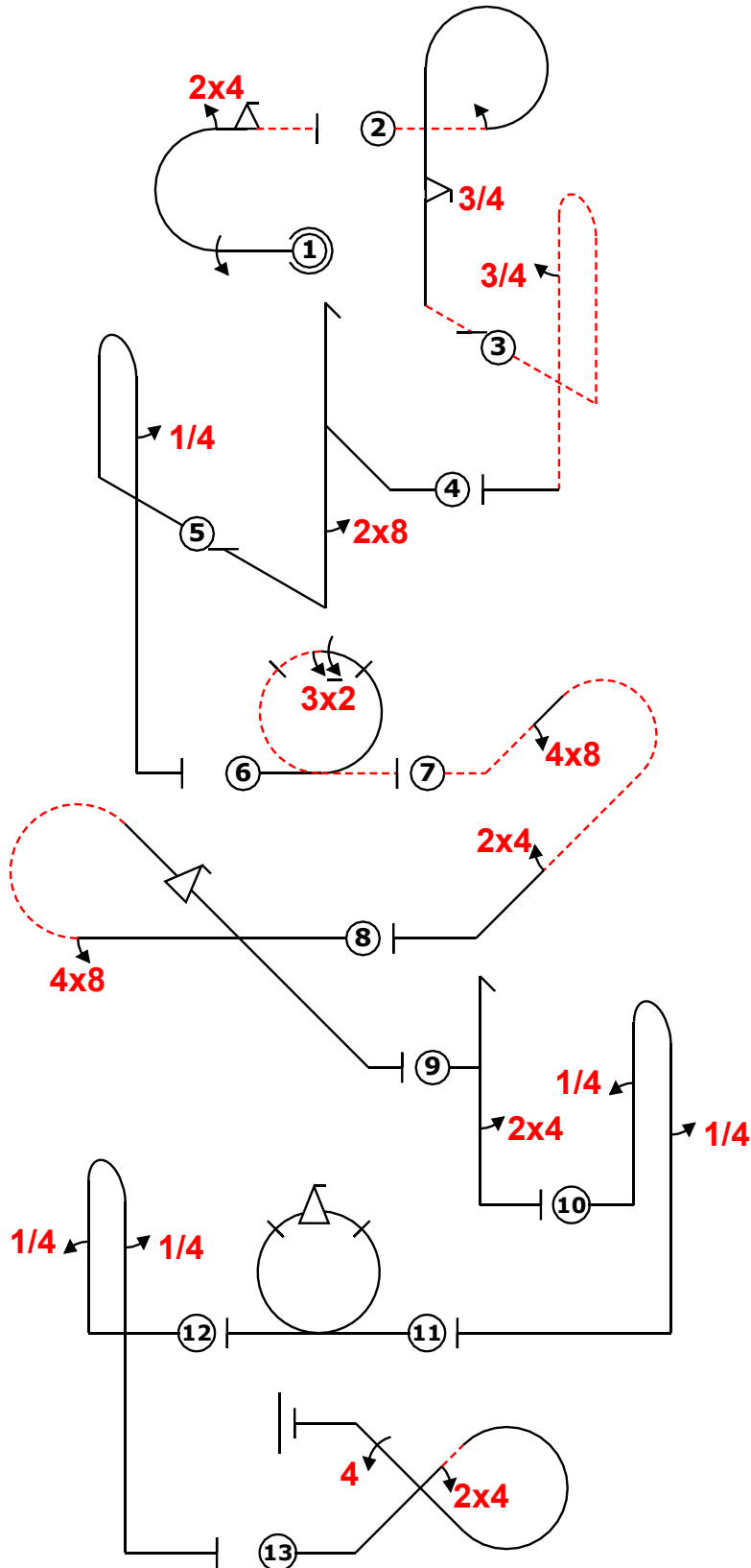
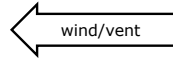

Pilot  
A/C

Pilot ID

France Advanced inconnu-libre 2

Flight #

C

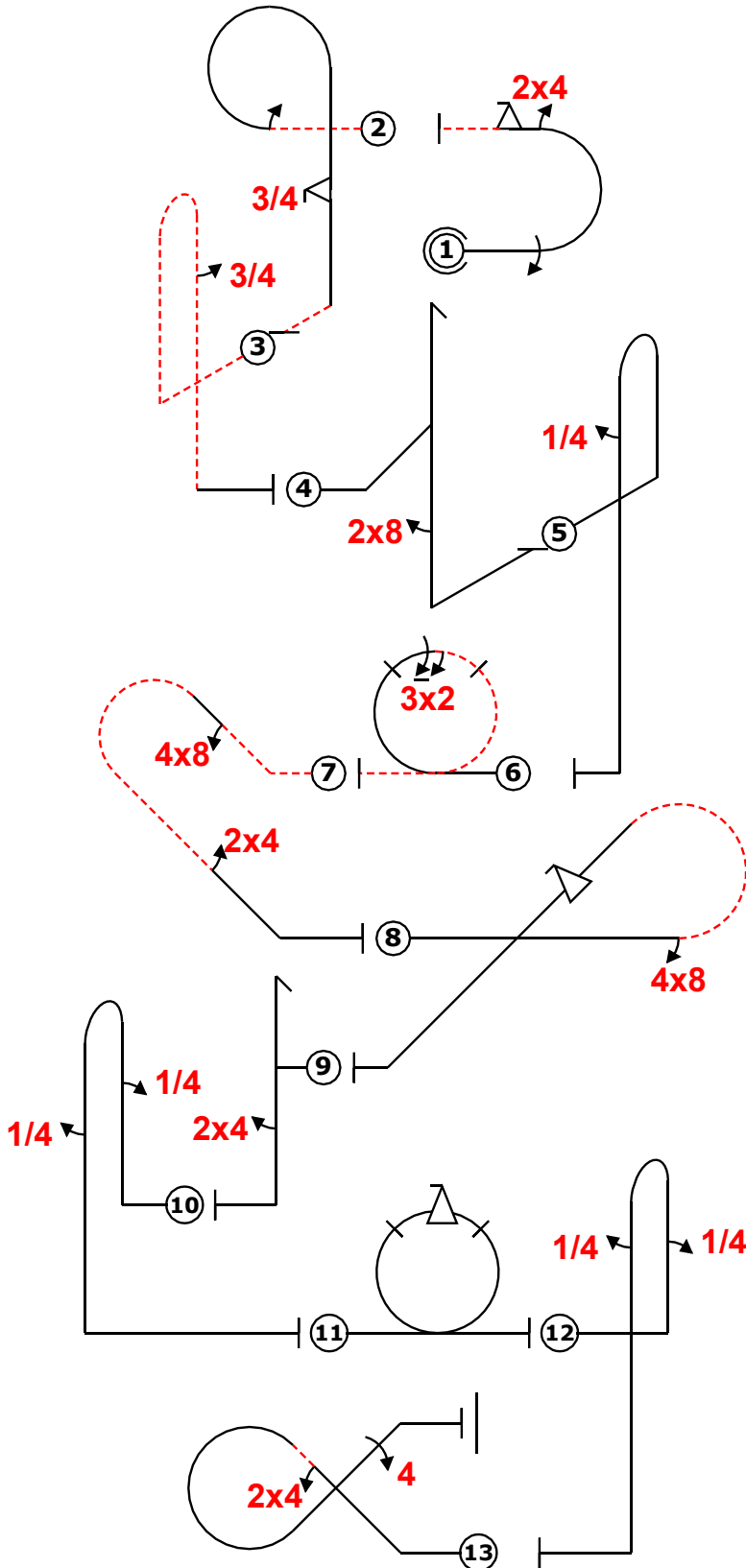
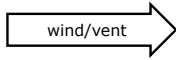

Pilot  
A/C

Pilot ID

France Advanced inconnu-libre 2

Flight #

D

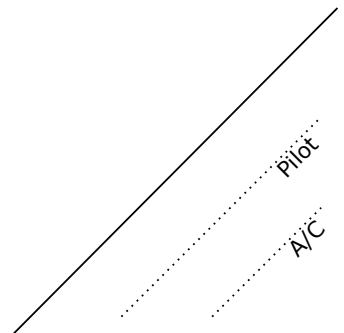
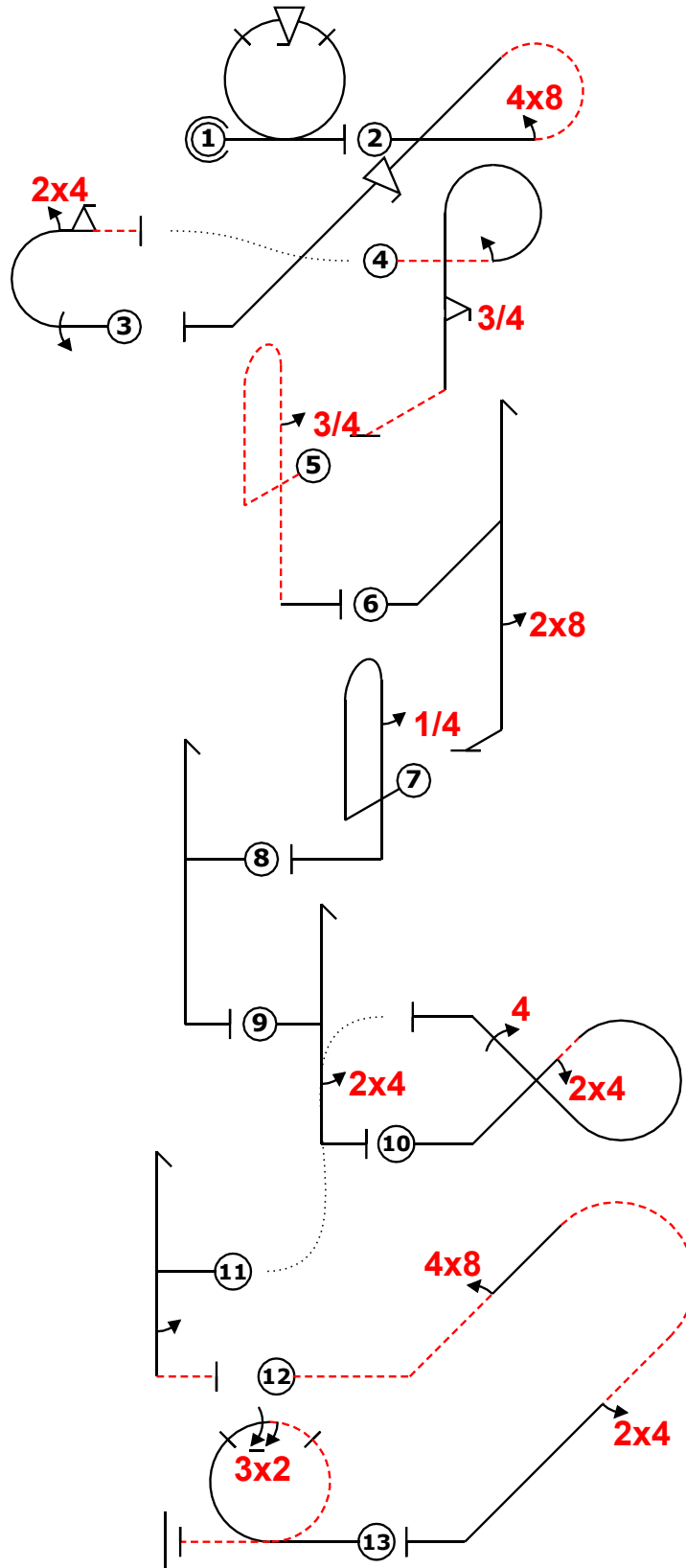
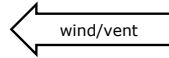

Pilot ID

Flight #

France Advanced inconnu-libre 2

D

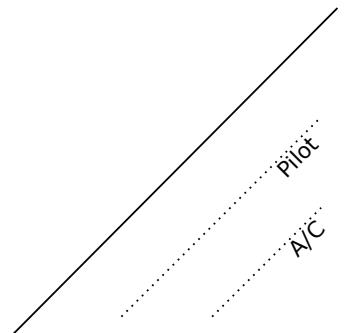
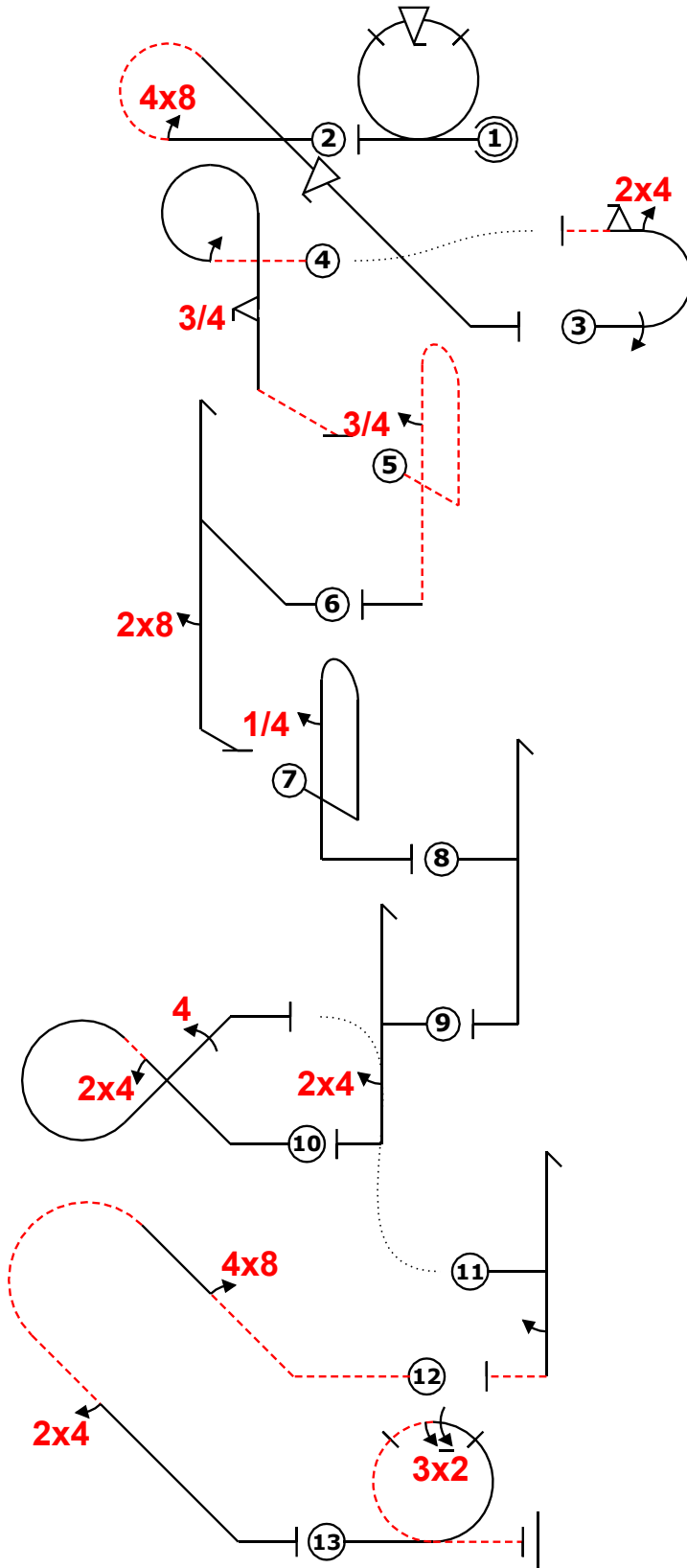
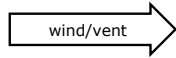



wind/vent ←

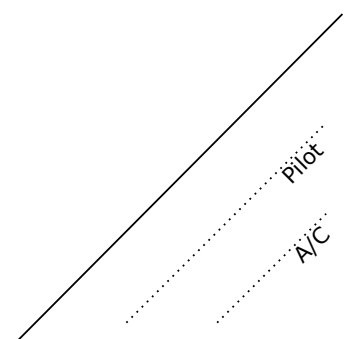
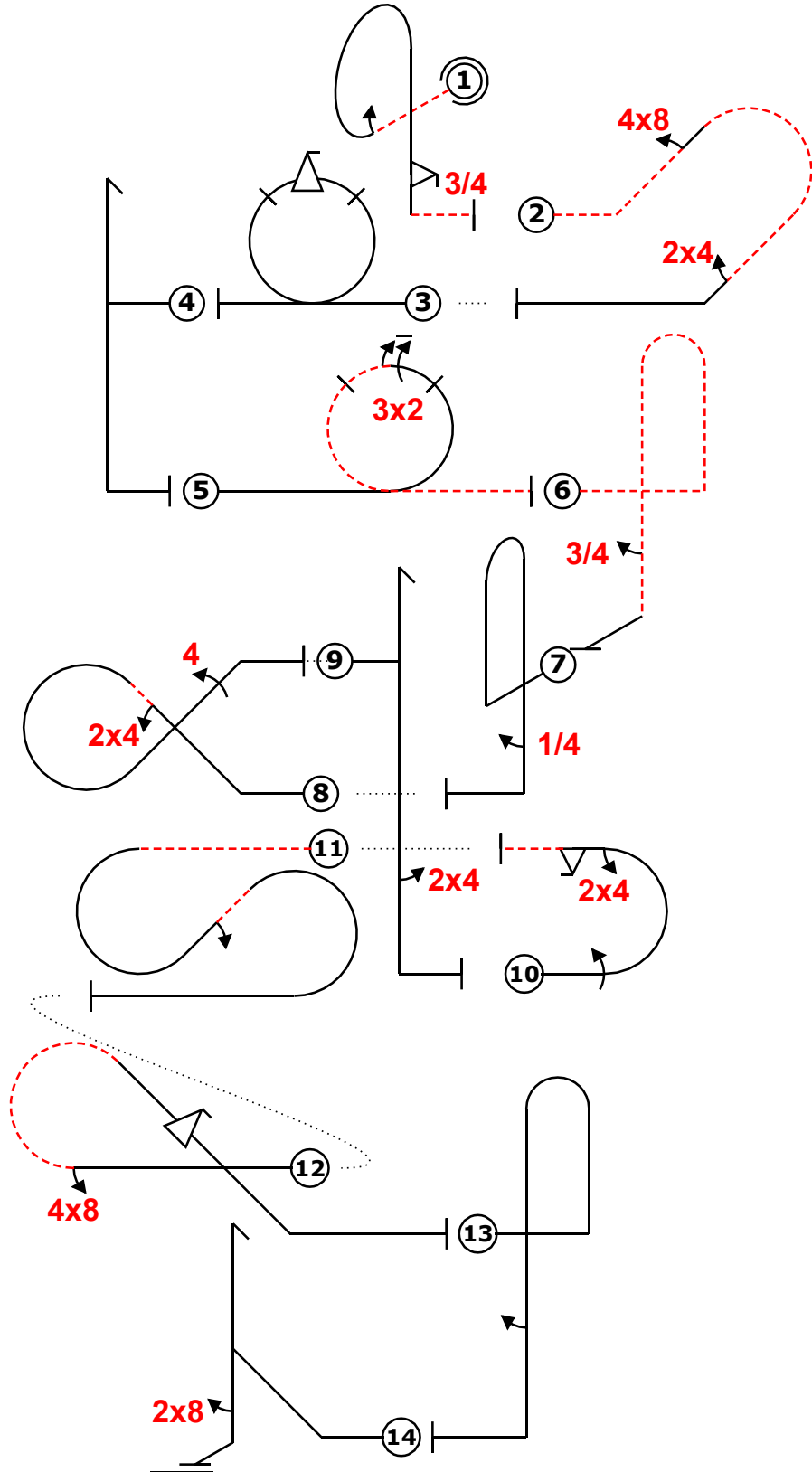



Pilot ID		Form C
CIVA Advanced Unknown2		Flight # F

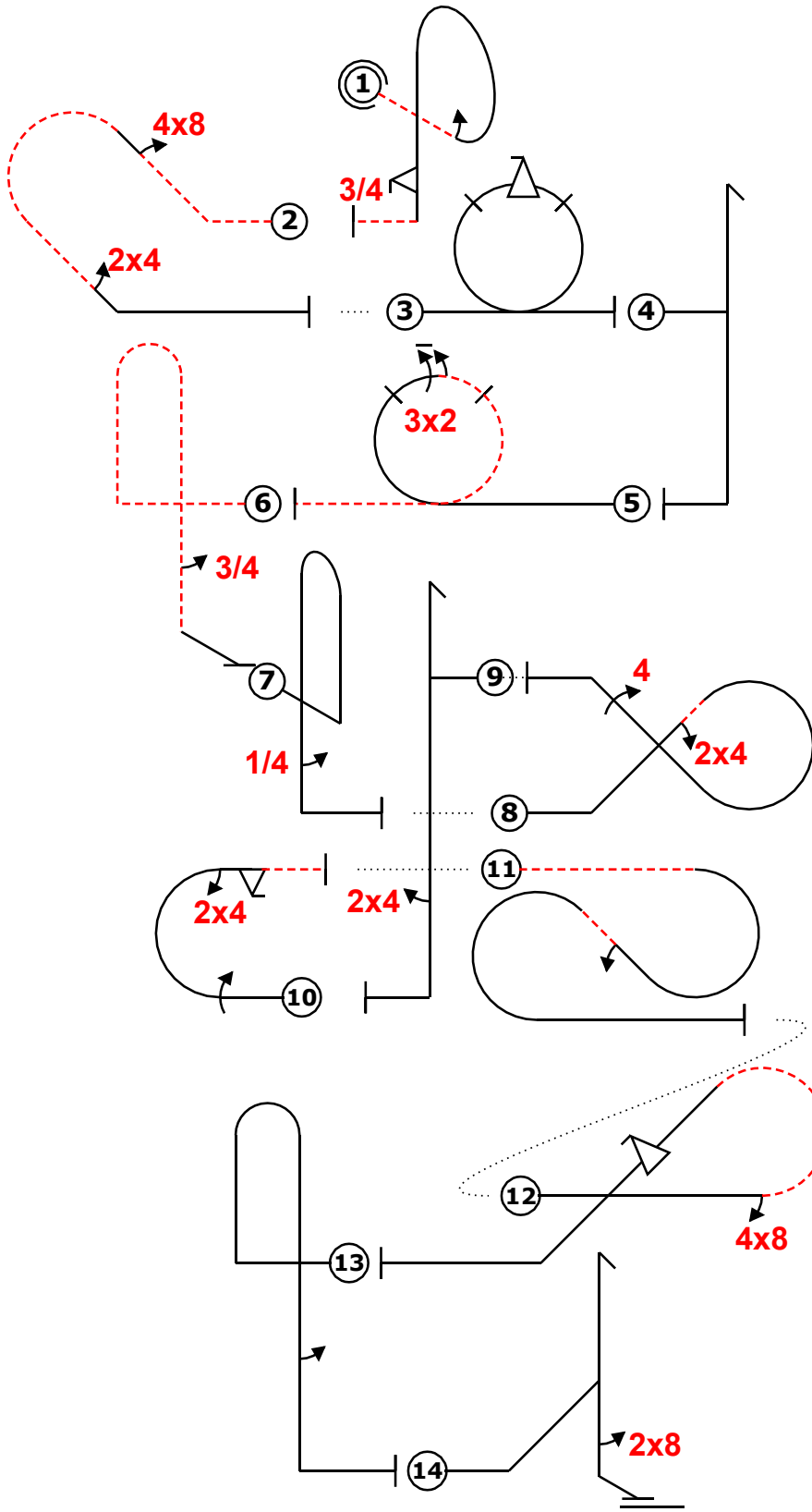
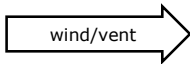

ej "@E" -,2p3f- 2> "@H" -48rdb,24 (-2,0) "@A" of "@L" h.. "@J" ~+o,"|32-- "@G" ~-pb.,3 "@L" b.,,|"4'+> (-4,0) "@C" 24g44 (-2,0) "@B" '+`h...`24..` 2> "@D" 1m24;2F- (-7,0) "@L" ~~~~~iac(,2)+~~~~ (18,11) "@F" 48c.f++ "@L" b.,',2. "@I" dh,8

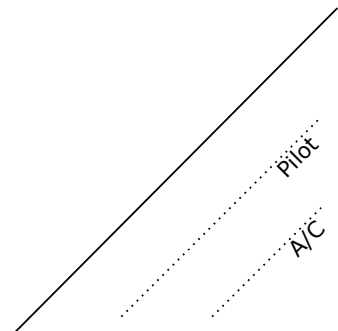

Pilot ID		Form B
France Advanced inconnu-libre 1		Flight # <b>H</b>

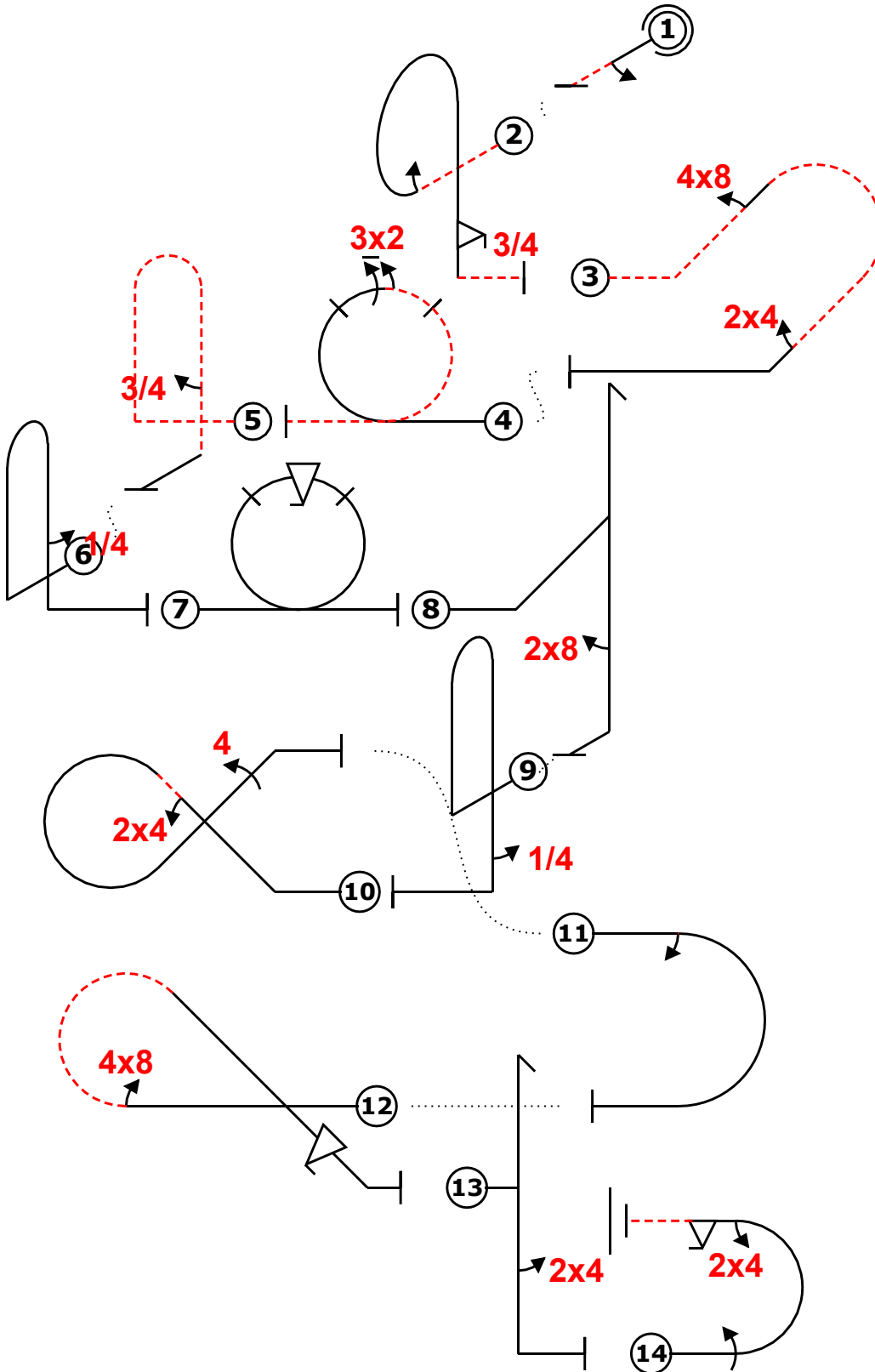
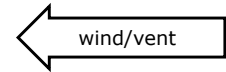

Power			
Fig	Aresti	K	
1	1.1.1.3	2	6
<b>Add.</b>	9.1.3.2	4	
2 E	8.6.8.2	13	28
	9.1.3.2	4	
	9.9.5.3	11	
3 H	8.4.16.2	16	30
	9.8.2.2	9	
	9.4.4.2	5	
4 J	7.4.2.1	12	24
	9.2.3.6	12	
5 G	8.4.2.2	17	23
	9.1.5.3	6	
<b>Add.</b>	8.4.1.1	13	6
	9.1.5.1	2	
7 A	7.4.1.1	10	21
	9.9.3.4	11	
8 I	5.3.1.1	18	21
	9.8.5.1	3	
<b>Add.</b>	8.4.1.1	13	6
	9.1.5.1	2	
10 C	7.3.2.1	14	34
	9.4.2.2	7	
	9.4.2.4	13	
<b>Add.</b>	7.2.3.3	6	6
	9.1.3.2	4	
12 F	8.5.7.1	12	30
	9.8.3.2	7	
	9.9.4.4	11	
13 B	5.2.1.1	17	22
	9.4.5.2	5	
14 D	7.2.1.1	6	30
	9.1.3.4	8	
	9.4.3.2	5	
	9.9.3.2	11	
<b>Total K = 287</b>			

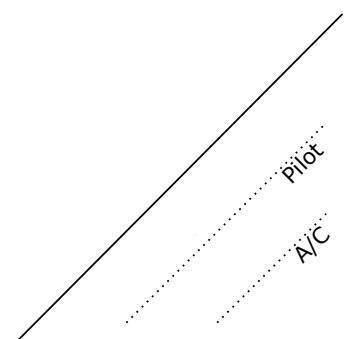

Pilot ID		Form C
France Advanced inconnu-libre 1		Flight # <b>H</b>

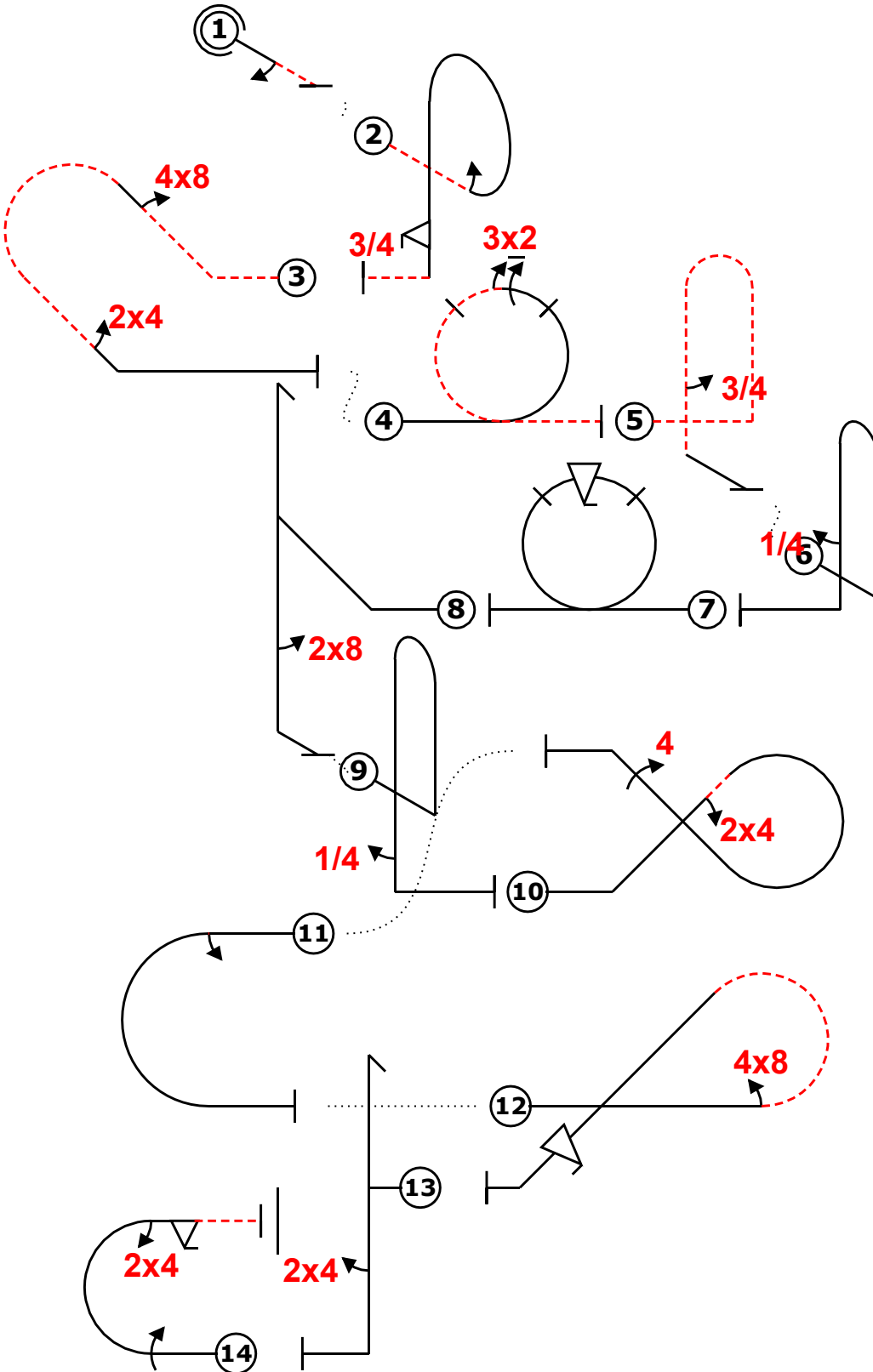
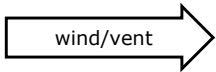

Power			
Fig	Aresti	K	
1	1.1.1.3	2	6
<b>Add.</b>	9.1.3.2	4	
2 E	8.6.8.2	13	28
	9.1.3.2	4	
	9.9.5.3	11	
3 H	8.4.16.2	16	30
	9.8.2.2	9	
	9.4.4.2	5	
4 J	7.4.2.1	12	24
	9.2.3.6	12	
5 G	8.4.2.2	17	23
	9.1.5.3	6	
<b>Add.</b>	8.4.1.1	13	6
	9.1.5.1	2	
7 A	7.4.1.1	10	21
	9.9.3.4	11	
8 I	5.3.1.1	18	21
	9.8.5.1	3	
<b>Add.</b>	8.4.1.1	13	6
	9.1.5.1	2	
10 C	7.3.2.1	14	34
	9.4.2.2	7	
	9.4.2.4	13	
<b>Add.</b>	7.2.3.3	6	6
	9.1.3.2	4	
12 F	8.5.7.1	12	30
	9.8.3.2	7	
	9.9.4.4	11	
13 B	5.2.1.1	17	22
	9.4.5.2	5	
14 D	7.2.1.1	6	30
	9.1.3.4	8	
	9.4.3.2	5	
	9.9.3.2	11	
<b>Total K = 287</b>			

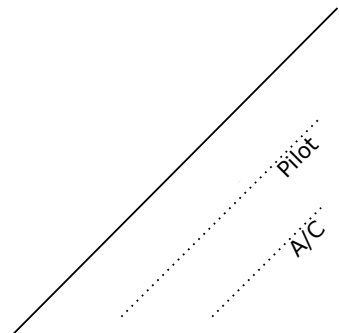

Pilot ID

France Advanced inconnu-libre 2

Flight #

I

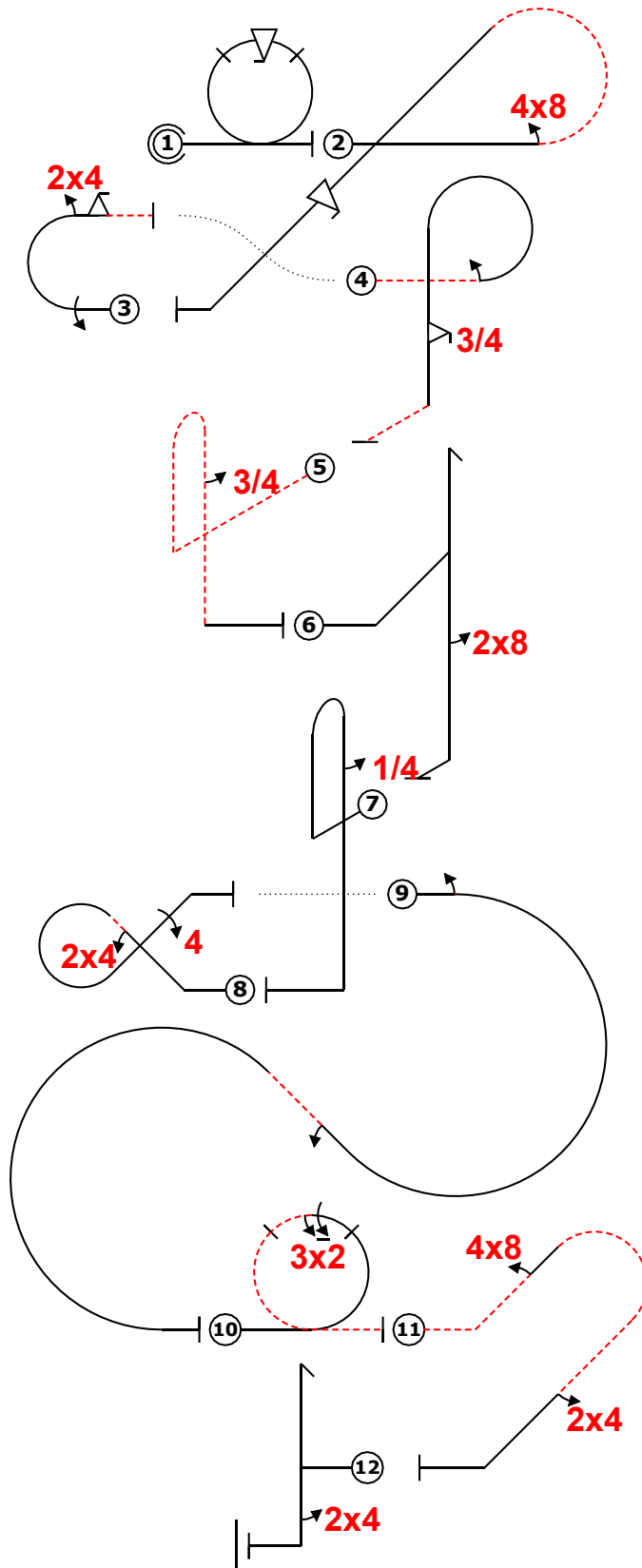
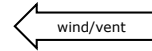

Power			
Fig	Aresti	K	
1	7.4.1.1	10	21
	9.9.3.4	11	
2	8.5.7.1	12	30
	9.8.3.2	7	
	9.9.4.4	11	
3	7.2.1.1	6	30
	9.1.3.4	8	
	9.4.3.2	5	
	9.9.3.2	11	
4	8.6.8.2	13	28
	9.1.3.2	4	
	9.9.5.3	11	
5	8.4.2.2	17	23
	9.1.5.3	6	
6	5.3.1.1	18	21
	9.8.5.1	3	
7	8.4.1.1	13	12
	9.1.5.1	2	
8	7.3.2.1	14	34
	9.4.2.2	7	
	9.4.2.4	13	
9	7.5.5.3	15	12
	9.1.3.2	4	
	9.1.2.2	6	
10	7.4.2.1	12	24
	9.2.3.6	12	
11	8.4.16.2	16	30
	9.8.2.2	9	
	9.4.4.2	5	
12	5.2.1.1	17	22
	9.4.5.2	5	
<b>Total K = 287</b>			

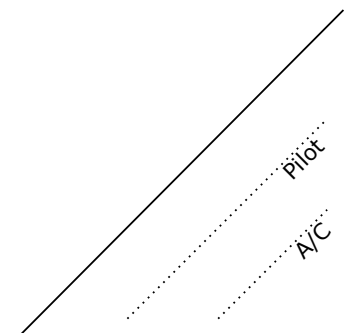

Pilot ID

France Advanced inconnu-libre 2

Flight #

I

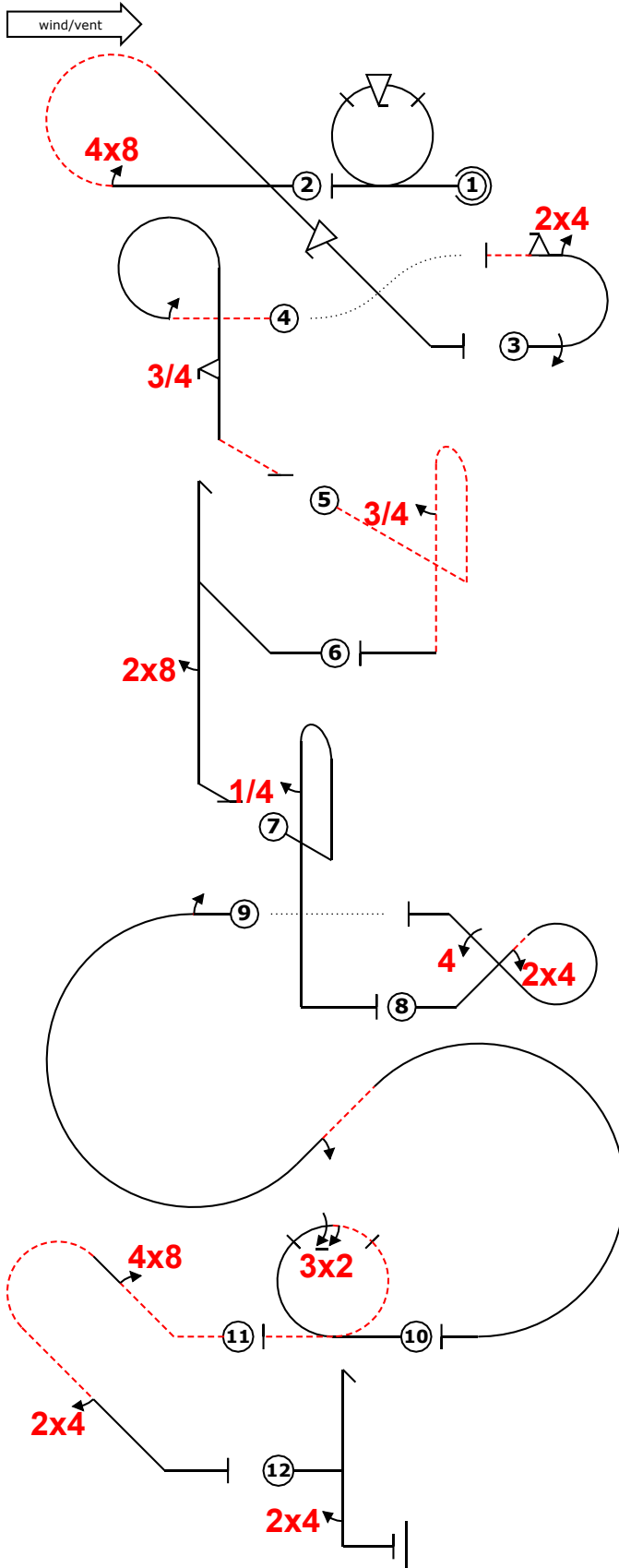

Power			
Fig	Aresti	K	
1	7.4.1.1	10	21
	A 9.9.3.4	11	
2	8.5.7.1	12	30
	F 9.8.3.2	7	
	9.9.4.4	11	
3	7.2.1.1	6	30
	D 9.1.3.4	8	
	9.4.3.2	5	
	9.9.3.2	11	
4	E 8.6.8.2	13	28
	9.1.3.2	4	
	G 9.9.5.3	11	
5	8.4.2.2	17	23
	G 9.1.5.3	6	
6	I 5.3.1.1	18	21
	I 9.8.5.1	3	
7	8.4.1.1	13	12
	Add. 9.1.5.1	2	
8	7.3.2.1	14	34
	C 9.4.2.2	7	
	9.4.2.4	13	
9	7.5.5.3	15	12
	Add. 9.1.3.2	4	
	9.1.2.2	6	
10	J 7.4.2.1	12	24
	J 9.2.3.6	12	
11	H 8.4.16.2	16	30
	H 9.8.2.2	9	
	H 9.4.4.2	5	
12	B 5.2.1.1	17	22
	B 9.4.5.2	5	
<b>Total K = 287</b>			

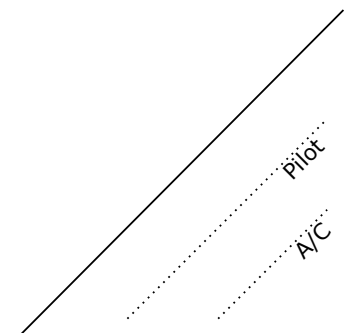

Pilot ID

France Advanced inconnu-libre 2

Flight #

J

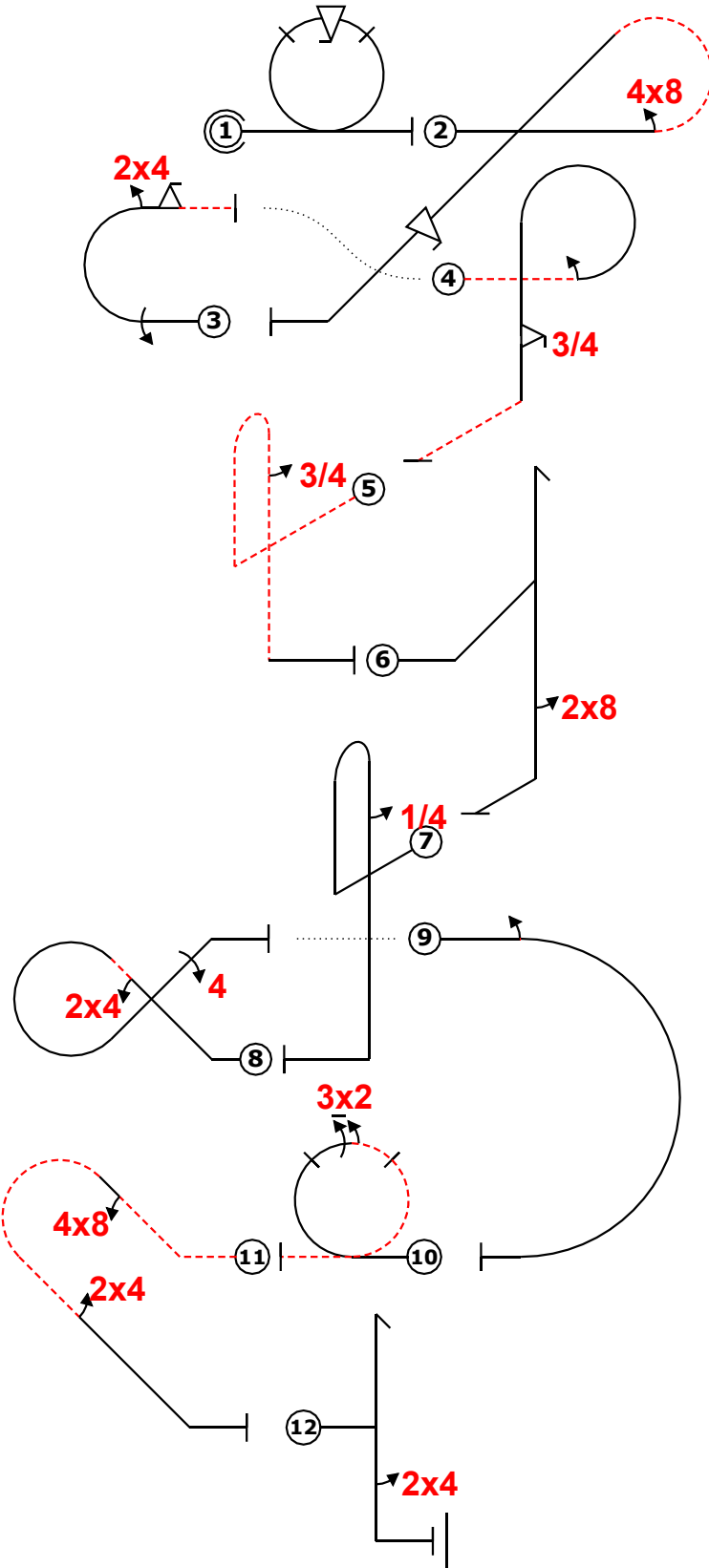
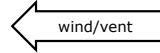

Power			
Fig	Aresti	K	
1	7.4.1.1	10	21
A	9.9.3.4	11	
2	8.5.7.1	12	30
F	9.8.3.2	7	
	9.9.4.4	11	
3	7.2.1.1	6	30
D	9.1.3.4	8	
	9.4.3.2	5	
	9.9.3.2	11	
4	8.6.8.2	13	28
E	9.1.3.2	4	
	9.9.5.3	11	
5	8.4.2.2	17	23
G	9.1.5.3	6	
6	5.3.1.1	18	21
I	9.8.5.1	3	
7	8.4.1.1	13	12
Add.	9.1.5.1	2	
8	7.3.2.1	14	34
C	9.4.2.2	7	
	9.4.2.4	13	
9	7.2.3.3	6	12
Add.	9.1.3.2	4	
10	7.4.2.1	12	24
J	9.2.3.6	12	
11	8.4.16.2	16	30
H	9.8.2.2	9	
	9.4.4.2	5	
12	5.2.1.1	17	22
B	9.4.5.2	5	
<b>Total K = 287</b>			

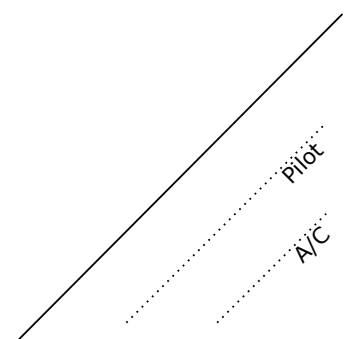

Pilot ID

France Advanced inconnu-libre 2

Flight #

J

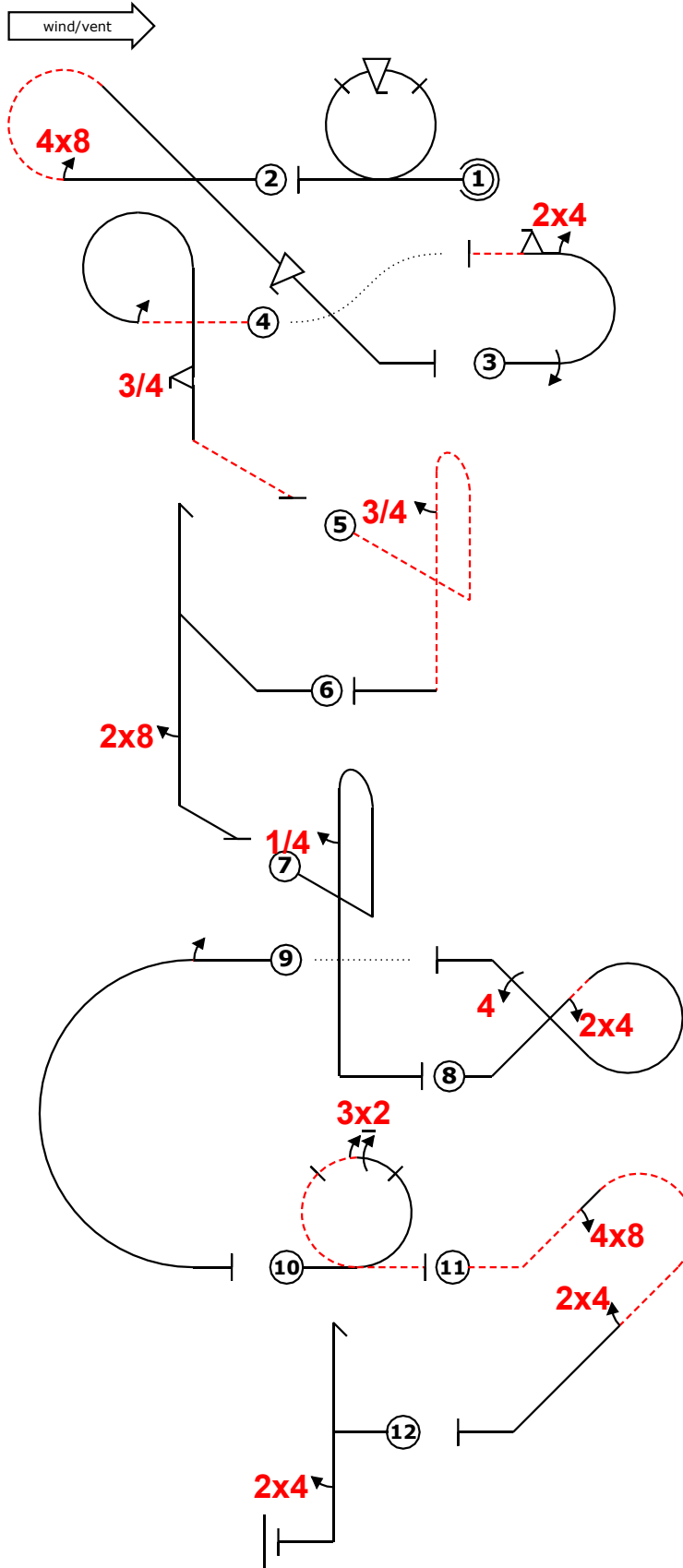

Power			
Fig	Aresti	K	
1 A	7.4.1.1	10	21
	9.9.3.4	11	
2 F	8.5.7.1	12	30
	9.8.3.2	7	
	9.9.4.4	11	
3 D	7.2.1.1	6	30
	9.1.3.4	8	
	9.4.3.2	5	
	9.9.3.2	11	
4 E	8.6.8.2	13	28
	9.1.3.2	4	
	9.9.5.3	11	
5 G	8.4.2.2	17	23
	9.1.5.3	6	
6 I	5.3.1.1	18	21
	9.8.5.1	3	
7 Add.	8.4.1.1	13	12
	9.1.5.1	2	
8 C	7.3.2.1	14	34
	9.4.2.2	7	
	9.4.2.4	13	
9 Add.	7.2.3.3	6	12
	9.1.3.2	4	
10 J	7.4.2.1	12	24
	9.2.3.6	12	
11 H	8.4.16.2	16	30
	9.8.2.2	9	
	9.4.4.2	5	
12 B	5.2.1.1	17	22
	9.4.5.2	5	
<b>Total K = 287</b>			

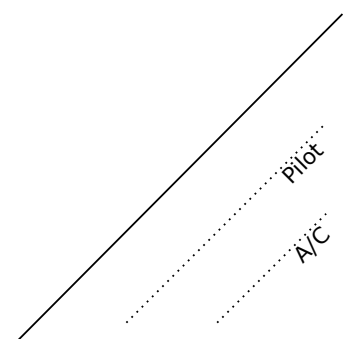



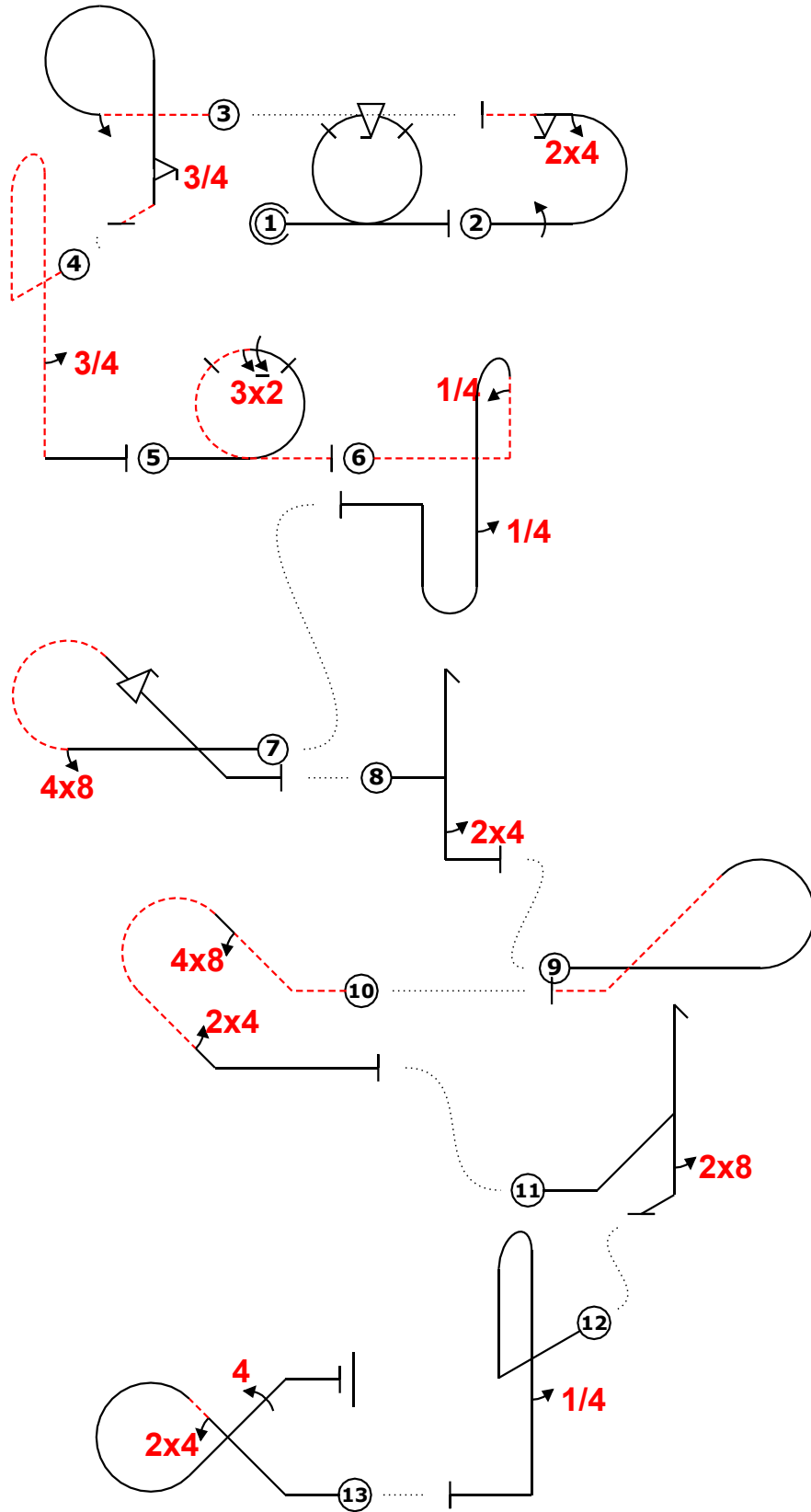
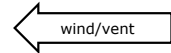

Power			
Fig	Aresti	K	
1	7.4.1.1	10	21
	9.9.3.4	11	
2	7.2.1.1	6	30
	9.1.3.4	8	
	9.4.3.2	5	
	9.9.3.2	11	
3	8.6.8.2	13	28
	9.1.3.2	4	
	9.9.5.3	11	
4	8.4.2.2	17	23
	9.1.5.3	6	
5	7.4.2.1	12	24
	9.2.3.6	12	
6 Add.	8.8.7.2	21	8
	9.1.1.1	6	
	9.1.5.1	2	
7 F	8.5.7.1	12	30
	9.8.3.2	7	
	9.9.4.4	11	
8 B	5.2.1.1	17	22
	9.4.5.2	5	
9 Add.	8.5.5.1	10	8
10 H	8.4.16.2	16	30
	9.8.2.2	9	
	9.4.4.2	5	
11 I	5.3.1.1	18	21
	9.8.5.1	3	
12 Add.	8.4.1.1	13	8
	9.1.5.1	2	
13 C	7.3.2.1	14	34
	9.4.2.2	7	
	9.4.2.4	13	
<b>Total K = 287</b>			

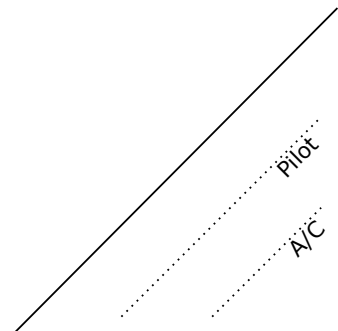



CF1 / Blois 20/06/2022

---

Pilot ID: CIVA Advanced Unknown2

Form C

---

Flight # K

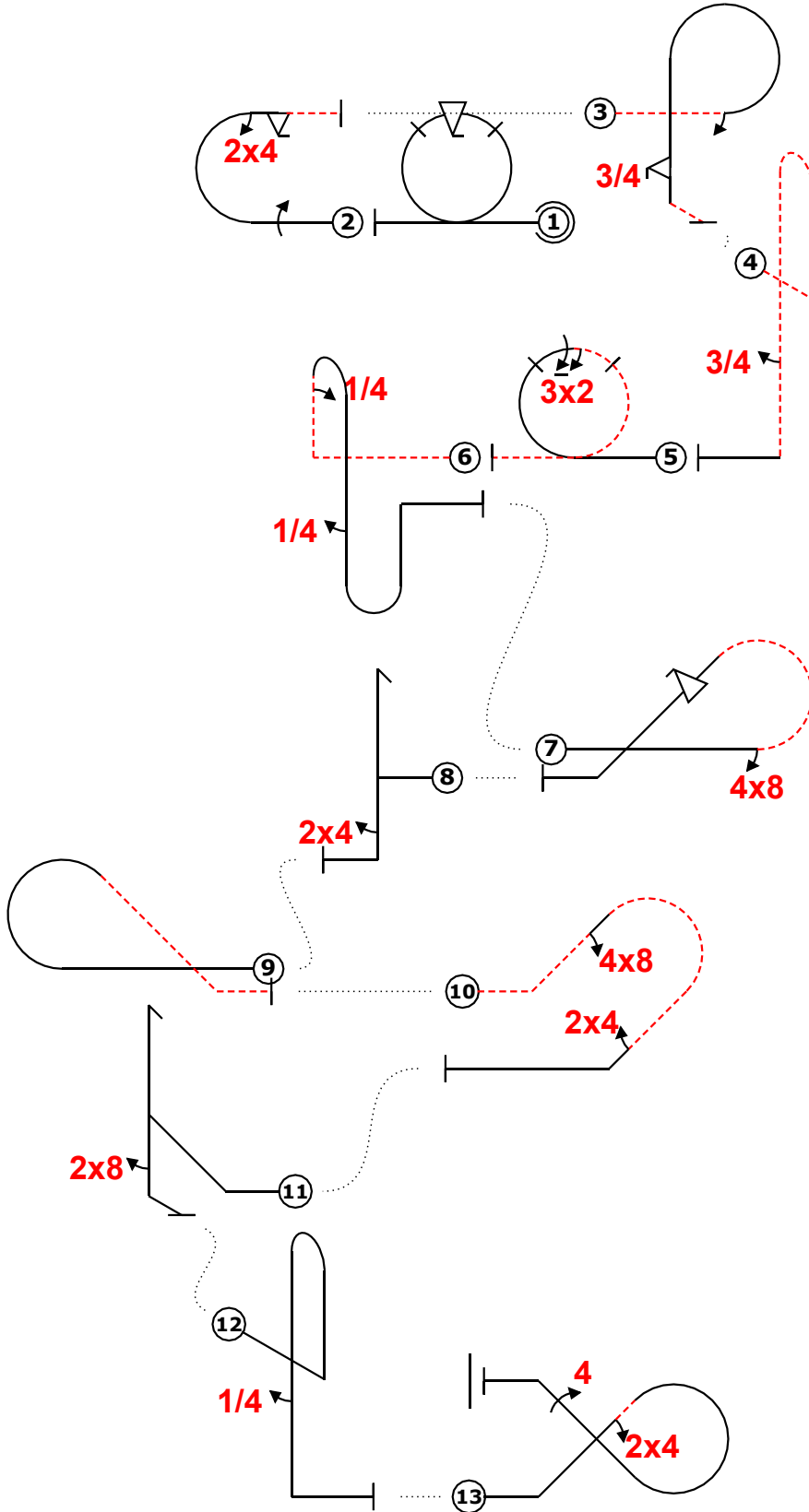
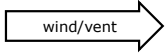

Power			
Fig	Aresti	K	
1	7.4.1.1	10	21
	9.9.3.4	11	
2	7.2.1.1	6	30
	9.1.3.4	8	
	9.4.3.2	5	
	9.9.3.2	11	
3	8.6.8.2	13	28
	9.1.3.2	4	
	9.9.5.3	11	
4	8.4.2.2	17	23
	9.1.5.3	6	
5	7.4.2.1	12	24
	9.2.3.6	12	
6	8.8.7.2	21	8
	9.1.1.1	6	
	9.1.5.1	2	
7	8.5.7.1	12	30
	9.8.3.2	7	
	9.9.4.4	11	
8	5.2.1.1	17	22
	9.4.5.2	5	
9	8.5.5.1	10	8
	8.5.5.1	10	
10	8.4.16.2	16	30
	9.8.2.2	9	
	9.4.4.2	5	
11	5.3.1.1	18	21
	9.8.5.1	3	
12	8.4.1.1	13	8
	9.1.5.1	2	
13	7.3.2.1	14	34
	9.4.2.2	7	
	9.4.2.4	13	
<b>Total K = 287</b>			

"@A" of "@D" 1'm24;2f- (-15,0) "@E" -2p3f- (0,1) "@G" -pb..'3.> "@J" o32- "@L" ~-4bb(4) (-1,18) "@F" 48cf (3,0) "@B" h24 (0,8) "@L" c- (-10,0) "@H" -48rdb24 (7,9) "@I" dh8 (0,6) "@L" ~+b..'4. (-3,0) "@C" 24g44

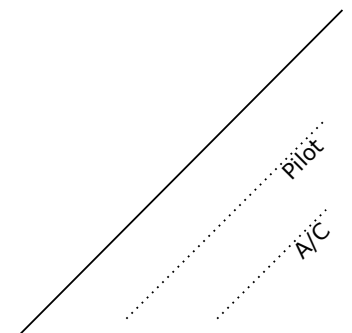

Pilot ID

France Advanced inconnu-libre 2

Flight #

L

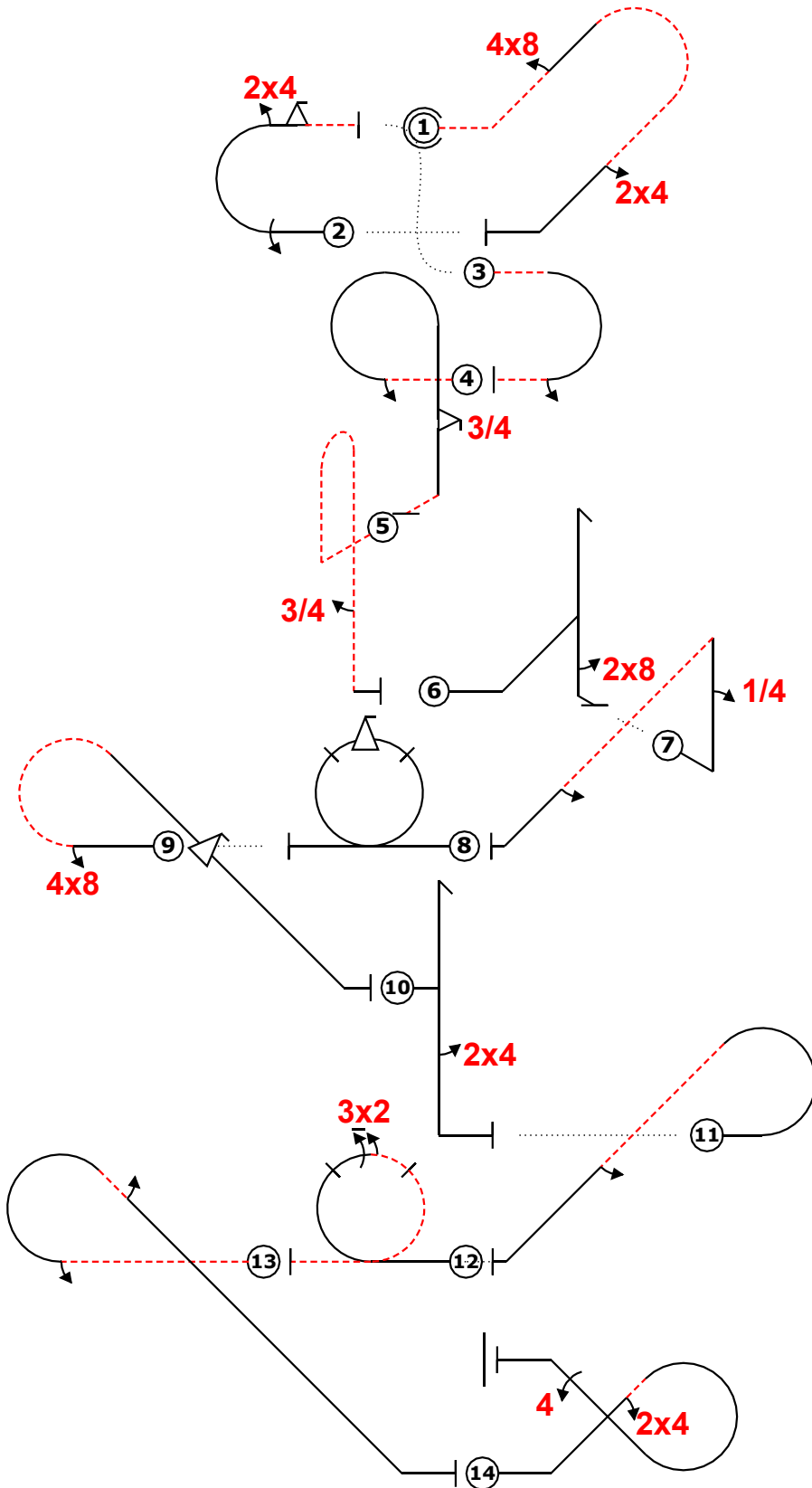
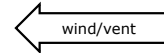

Power			
Fig	Aresti	K	
1 H	8.4.16.2	16	30
	9.8.2.2	9	
	9.4.4.2	5	
2 D	7.2.1.1	6	30
	9.1.3.4	8	
	9.4.3.2	5	
	9.9.3.2	11	
3 Add.	7.2.2.4	7	6
	9.1.3.2	4	
4 E	8.6.8.2	13	28
	9.1.3.2	4	
	9.9.5.3	11	
5 G	8.4.2.2	17	23
	9.1.5.3	6	
6 I	5.3.1.1	18	21
	9.8.5.1	3	
7 Add.	1.2.7.1	13	6
	9.1.1.1	6	
	9.1.4.2	4	
8 A	7.4.1.1	10	21
	9.9.3.4	11	
9 F	8.5.7.1	12	30
	9.8.3.2	7	
	9.9.4.4	11	
10 B	5.2.1.1	17	22
	9.4.5.2	5	
11 Add.	8.5.6.1	10	6
	9.1.4.2	4	
12 J	7.4.2.1	12	24
	9.2.3.6	12	
13 Add.	8.5.8.2	11	6
	9.1.3.2	4	
	9.1.4.2	4	
14 C	7.3.2.1	14	34
	9.4.2.2	7	
	9.4.2.4	13	
<b>Total K = 287</b>			

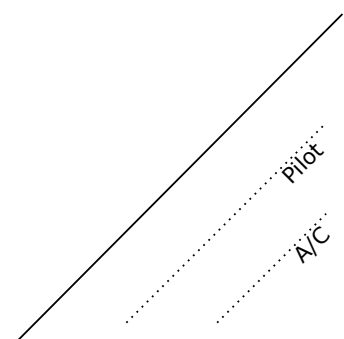

Pilot ID

France Advanced inconnu-libre 2

Flight #

L

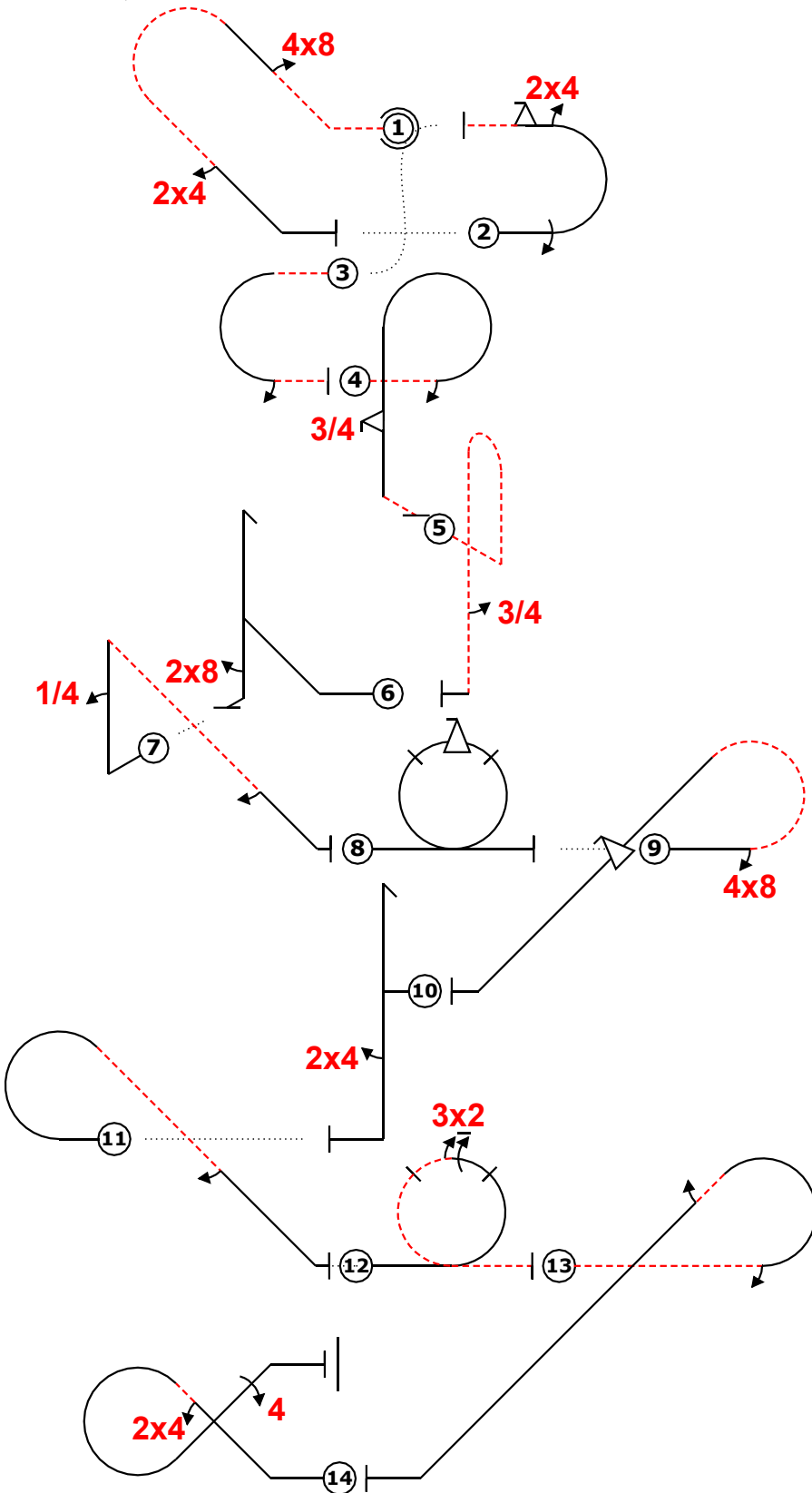
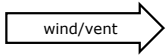

Power			
Fig	Aresti	K	
1 H	8.4.16.2	16	30
	9.8.2.2	9	
	9.4.4.2	5	
2 D	7.2.1.1	6	30
	9.1.3.4	8	
	9.4.3.2	5	
	9.9.3.2	11	
3 Add.	7.2.2.4	7	6
	9.1.3.2	4	
4 E	8.6.8.2	13	28
	9.1.3.2	4	
	9.9.5.3	11	
5 G	8.4.2.2	17	23
	9.1.5.3	6	
6 I	5.3.1.1	18	21
	9.8.5.1	3	
7 Add.	1.2.7.1	13	6
	9.1.1.1	6	
	9.1.4.2	4	
8 A	7.4.1.1	10	21
	9.9.3.4	11	
9 F	8.5.7.1	12	30
	9.8.3.2	7	
	9.9.4.4	11	
10 B	5.2.1.1	17	22
	9.4.5.2	5	
11 Add.	8.5.6.1	10	6
	9.1.4.2	4	
12 J	7.4.2.1	12	24
	9.2.3.6	12	
13 Add.	8.5.8.2	11	6
	9.1.3.2	4	
	9.1.4.2	4	
14 C	7.3.2.1	14	34
	9.4.2.2	7	
	9.4.2.4	13	
<b>Total K = 287</b>			

