





Aerofestival Mai 2022

Form A

Pilote ID

France Unlimited inconnu-libre

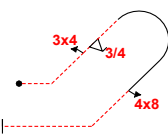
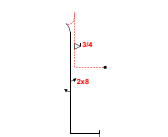
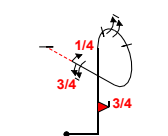
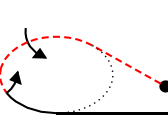
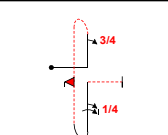
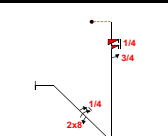
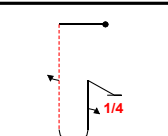
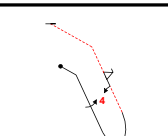
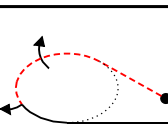
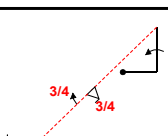
Vol N°

No	Symbol	Cat. No.	K	Total K	Grade	Pos	Remarks	Item	K	Grade
1		8.4.18.2 9.4.2.3 9.9.2.3 9.8.4.2	14	Fig A 44	.			Pos.	40	
			10					Harm.	0	
2		6.2.2.4 9.9.6.3 9.8.5.1 9.1.5.2	17	Fig B 41	.			Fig K	Total K	
			17					469	509	
3		8.6.2.1 9.10.6.3 9.1.3.8 9.1.3.7 9.1.3.1	12	Fig C 56	.			Penalties		
			19					Trop Bas		
4		2.3.2.2	34	Fig D 34	.			Trop Haut		
								Interruptions		
5		8.8.5.1 9.1.1.3 9.10.5.2 9.1.1.5	21	Fig E 58	.			Insertions		
			10					Echaf. non OK		
6		1.2.5.4 9.12.1.5 9.1.5.3 9.8.2.1 9.1.2.5	14	Fig F 42	.			Battem. d'Ailes		
			6					Disqualifié		
7		8.4.3.3 9.1.5.2 9.1.1.1	15	25	.			Autre(noter...)		
			4					Final Freestyle		
8		8.4.17.3 9.4.4.4 9.1.2.2 9.9.2.2	11	Fig G 41	.			Duration	Min	Sec
			11							
9		2.3.2.4	37	Fig H 37	.			Judges Details		
								Signature		
10		1.2.5.1 9.1.1.4 9.9.9.3 9.1.4.3	14	Fig I 45	.			Name		
			12					Number		
11		5.2.1.4 9.10.1.3 9.8.5.2	22	Fig J 46	.			Signature		
			17					Pilote		
			7					Avion		

Pilote
Avion



Pilote ID

France Unlimited inconnu-libre

Vol N°

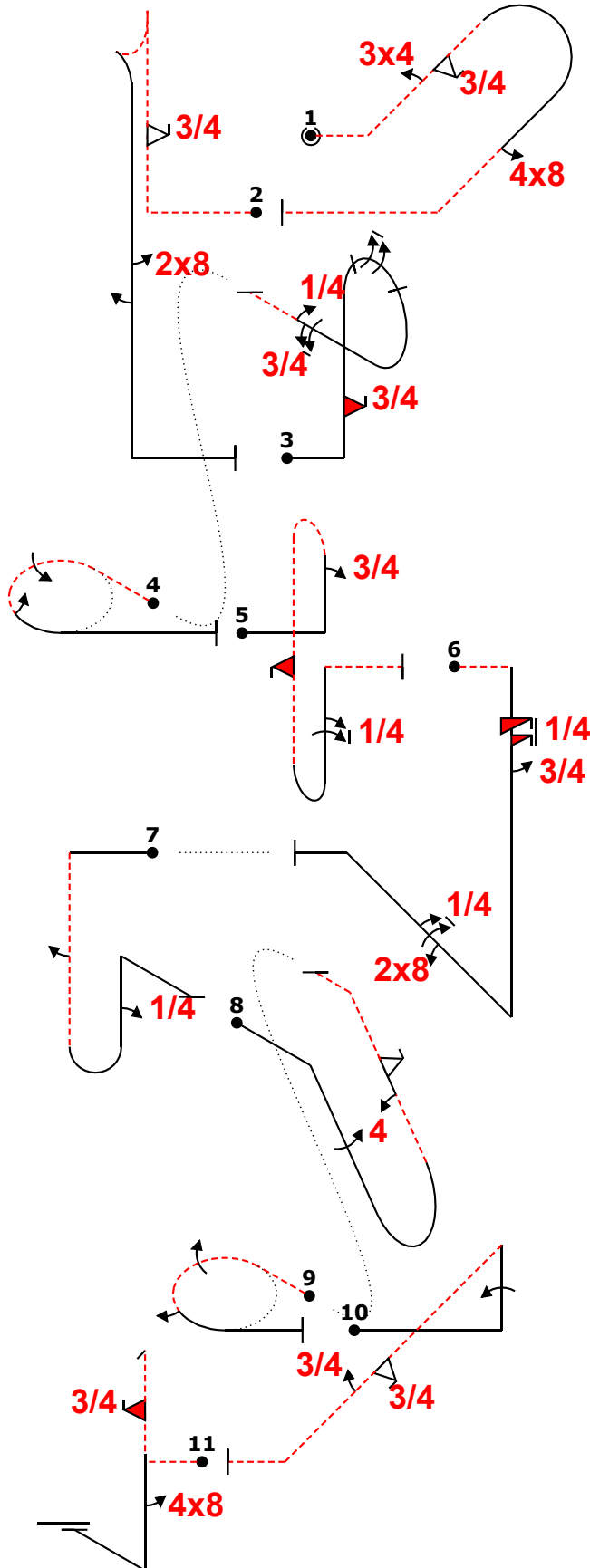

Avion			
Fig	Aresti	K	
1 A	8.4.18.2	14	44
	9.4.2.3	10	
	9.9.2.3	13	
	9.8.4.2	7	
2 B	6.2.2.4	17	41
	9.9.6.3	17	
	9.8.5.1	3	
	9.1.5.2	4	
3 C	8.6.2.1	12	56
	9.10.6.3	19	
	9.1.3.8	12	
	9.1.3.7	11	
	9.1.3.1	2	
4 D	2.3.2.2	34	34
5 E	8.8.5.1	21	58
	9.1.1.3	10	
	9.10.5.2	13	
	9.1.1.5	14	
6 F	1.2.5.4	14	42
	9.12.1.5	6	
	9.1.5.3	6	
	9.8.2.1	5	
	9.1.2.5	11	
7	8.4.3.3	15	25
	9.1.5.2	4	
	9.1.1.1	6	
8 G	8.4.17.3	11	41
	9.4.4.4	11	
	9.1.2.2	6	
	9.9.2.2	13	
9 H	2.3.2.4	37	37
10 I	1.2.5.1	14	45
	9.1.1.4	12	
	9.9.9.3	13	
	9.1.4.3	6	
11 J	5.2.1.4	22	46
	9.10.1.3	17	
	9.8.5.2	7	
Total K = 469			

"@A" /-34,3f''ndb48.''- "@B" -.,3f.ita..8''',2...' (0,0) "@C" ,3ifrp(9)...''7,4^- (-4,26) "@D" ^-3j15+>> "@E" ,3pbb(,2if.)''',5-> (0,0) "@F" ^-5is;3....ik8,5 (-7,0) ''',|"2..'ib''',4+ (0,0) "@G" 1% ~+44.irdb'2,2f.~ (3,27) "@H" ^-3jo15+>> (0,0) 1% "@I" ++''1'k.'3f,3 - "@J" ^-3ifh48.+~

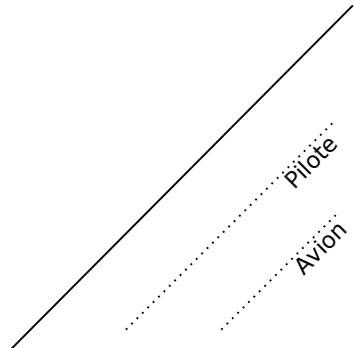



Aerofestival Mai 2022

Form C

Pilote ID

Vol N°

France Unlimited inconnu-libre

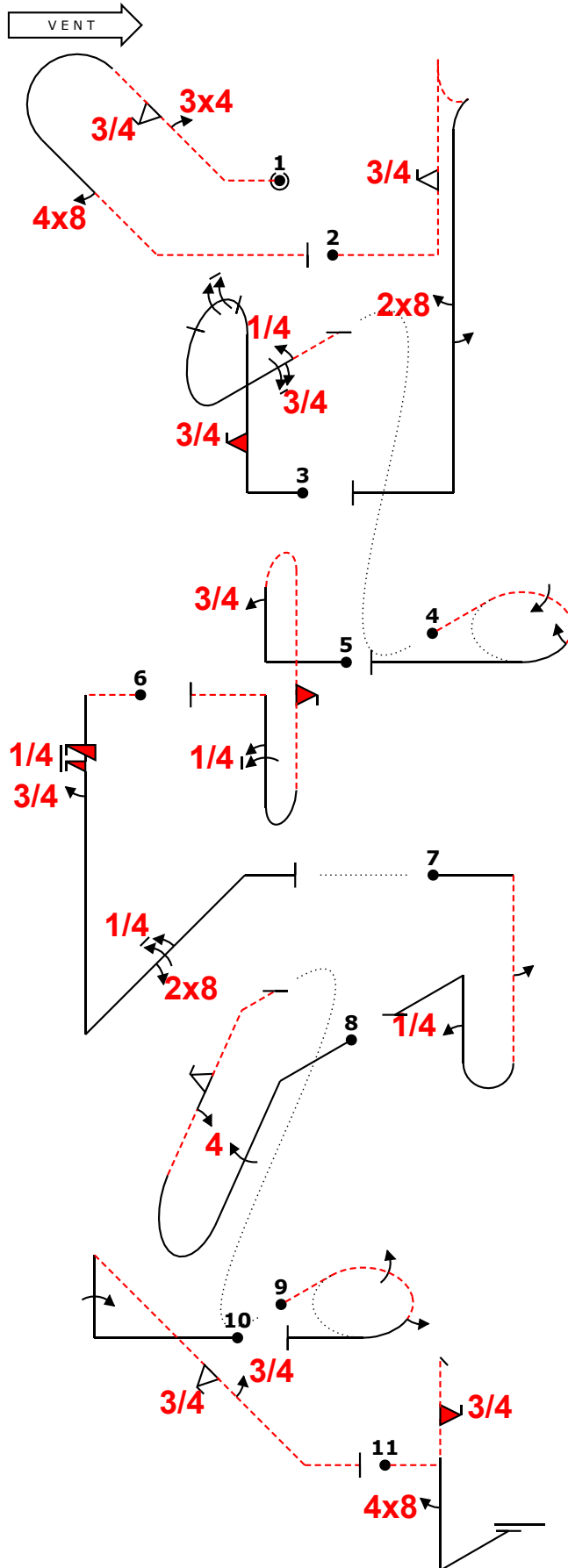

"@A" /-34,3f''ndb48.''- "@B" -.,3f.ita..8'',2... (0,0) "@C" ,3ifrp(9)...''7,4^- (-4,26) "@D" ^-3j15+>> "@E" ,3pbb(,2if.)''5-> (0,0) "@F"
 ^5is;3.....ik8,5 (-7,0) '',"|2..'ib''',4+ (0,0) "@G" 1% ~+44.irdb'2,2f.-..... (3,27) "@H" ^-3jo15+''>> (0,0) 1% "@I" ++''1'k.'3f,3
 ^- "@J" ^-3ifh48.+~

Pilote
 Avion



France Unlimited Mai 2022
 inconnu-libre Aerofestival

← VENT **R**

Figure K
469
 K total
509

Nom des Juges
 Signature Numéro

Vol N°

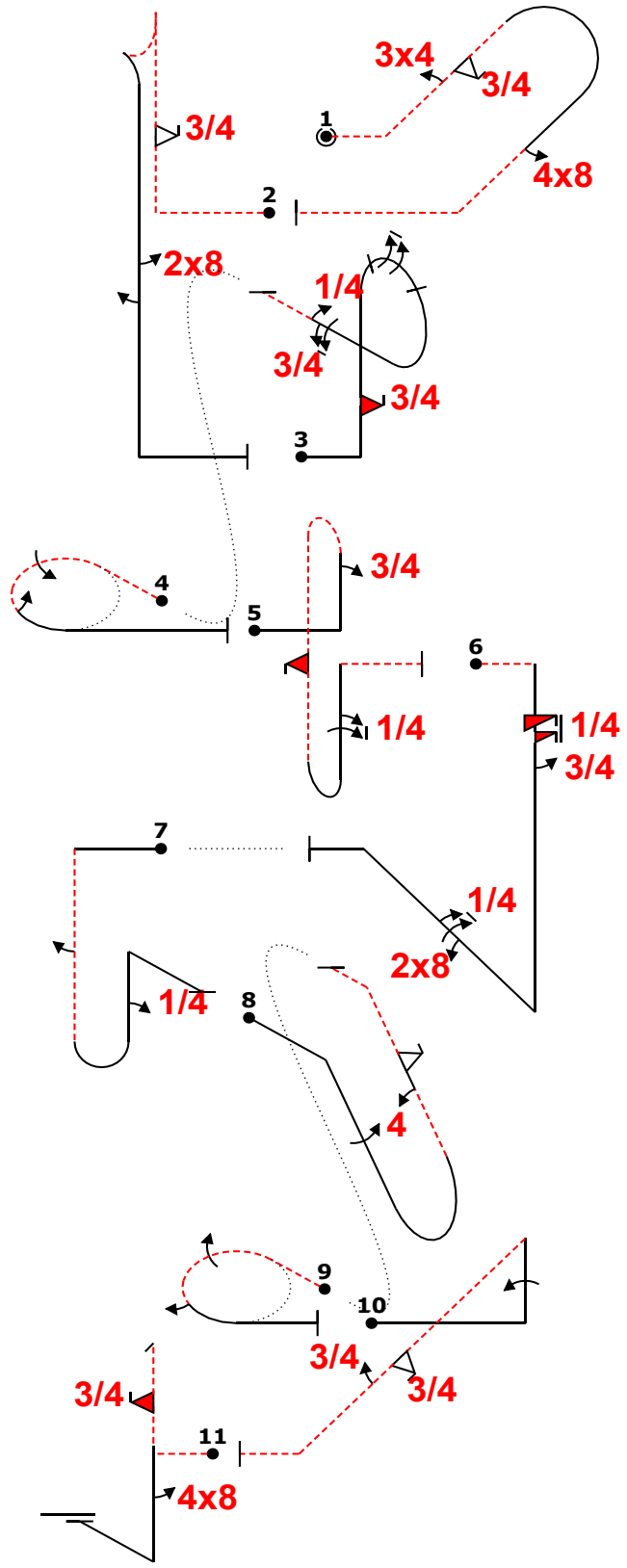

Fig	Grade	Pos	Remarks
1	.		
2	.		
3	.		
4	.		
5	.		
6	.		
7	.		
8	.		
9	.		
10	.		
11	.		

Cadre(Coef)
40 .

Trop Bas		Echauf. non OK	
Trop Haut		Battem. d'Ailes	
Interruptions		Disqualifié	
Insertions		Autre(noter...)	

"@A" /-34,3f''rdb48.''- "@B" -',3f.ita..8'',2...' (0,0) "@C" ,3ifrp(9)...''7,4-^ (-4,26) "@D" '-3j15+>> "@E" ,3 pbb(,2if.)''',5-> (0,0) "@F" -''5is;3.....ik8,5 (-7,0) ''',|"2.'''ib''''',4+ (0,0) "@G" 1% ~+44.irdb'2,2f.-..... (3,27) "@H" -''-3jo15+''>> (0,0) 1% "@I" +''''1'k.'3f,3'- "@J" -3ifh48.+~

Fig 1 A	K	Fig 2 B	K	Fig 3 C	K	Fig 4 D	K	Fig 5 E	K	Fig 6 F	K	Fig 7	K	Fig 8 G	K	Fig 9 H	K	Fig 10 I	K	Fig 11 J	K
8.4.18.2	14	6.2.2.4	17	8.6.2.1	12	2.3.2.2	34	8.8.5.1	21	1.2.5.4	14	8.4.3.3	15	8.4.17.3	11	2.3.2.4	37	1.2.5.1	14	5.2.1.4	22
9.4.2.3	10	9.9.6.3	17	9.10.6.3	19			9.1.1.3	10	9.12.1.5	6	9.1.5.2	4	9.4.4.4	11			9.1.1.4	12	9.10.1.3	17
9.9.2.3	13	9.8.5.1	3	9.1.3.8	12			9.10.5.2	13	9.1.5.3	6	9.1.1.1	6	9.1.2.2	6			9.9.9.3	13	9.8.5.2	7
9.8.4.2	7	9.1.5.2	4	9.1.3.7	11			9.1.1.5	14	9.8.2.1	5			9.9.2.2	13			9.1.4.3	6		
	44		41	9.1.3.1	2		34	9.1.2.5	11		42		25		41		37		45		46

Pilote:

Avion:

Equipe: FRA



France Unlimited Mai 2022
 inconnu-libre Aerofestival

Figure K
469
 K total
509

Nom des Juges
 Signature Numéro

Vol N°

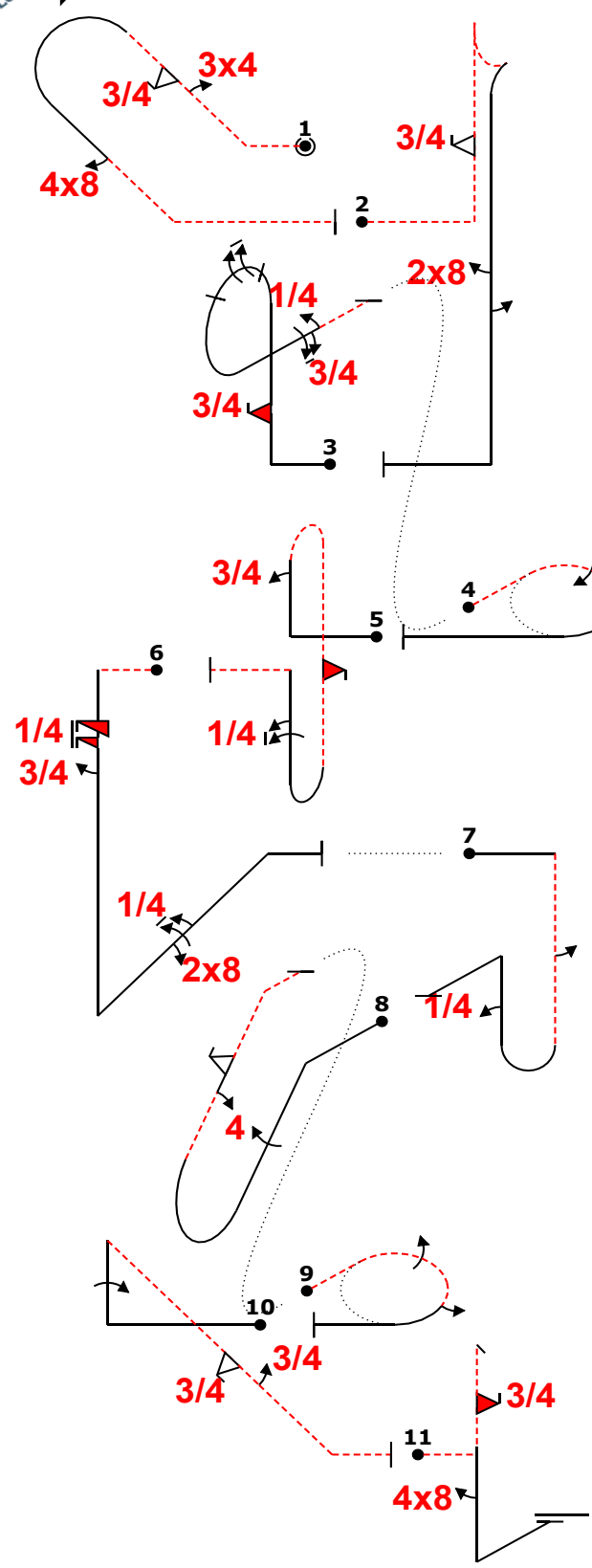

Fig	Grade	Pos	Remarks
1	.		
2	.		
3	.		
4	.		
5	.		
6	.		
7	.		
8	.		
9	.		
10	.		
11	.		

Cadre(Coef)
40 .

Trop Bas		Echauf. non OK	
Trop Haut		Battem. d'Ailes	
Interruptions		Disqualifié	
Insertions		Autre(noter...)	

"@A" /-34,3f''rdb48.''- "@B" -',3f.ita..8'',2...' (0,0) "@C" ,3ifrp(9)...''7,4^- (-4,26) "@D" '-3j15+>> "@E" ,3 pbb(,2if.)''',5-> (0,0) "@F" -''5is;3.....ik8,5 (-7,0) ''',|"2.'''ib''',4+ (0,0) "@G" 1% ~+44.irdb'2,2f.-..... (3,27) "@H" -''-3jo15+''>> (0,0) 1% "@I" ++''1'k.'3f,3'- "@J" -3ifh48.+~

Fig 1 A	K	Fig 2 B	K	Fig 3 C	K	Fig 4 D	K	Fig 5 E	K	Fig 6 F	K	Fig 7	K	Fig 8 G	K	Fig 9 H	K	Fig 10 I	K	Fig 11 J	K
8.4.18.2	14	6.2.2.4	17	8.6.2.1	12	2.3.2.2	34	8.8.5.1	21	1.2.5.4	14	8.4.3.3	15	8.4.17.3	11	2.3.2.4	37	1.2.5.1	14	5.2.1.4	22
9.4.2.3	10	9.9.6.3	17	9.10.6.3	19			9.1.1.3	10	9.12.1.5	6	9.1.5.2	4	9.4.4.4	11			9.1.1.4	12	9.10.1.3	17
9.9.2.3	13	9.8.5.1	3	9.1.3.8	12			9.10.5.2	13	9.1.5.3	6	9.1.1.1	6	9.1.2.2	6			9.9.9.3	13	9.8.5.2	7
9.8.4.2	7	9.1.5.2	4	9.1.3.7	11			9.1.1.5	14	9.8.2.1	5			9.9.2.2	13			9.1.4.3	6		
	44		41	9.1.3.1	56		34	9.1.2.5	58	9.1.2.5	42		25		41		37		45		46

Pilote:

Avion:

Equipe: FRA

