

CIVA

FAI

AEROBATICS  
COMMISSION

Form B

Pilot ID

CIVA Unlimited Free Known

Flight #

wind/vent ←

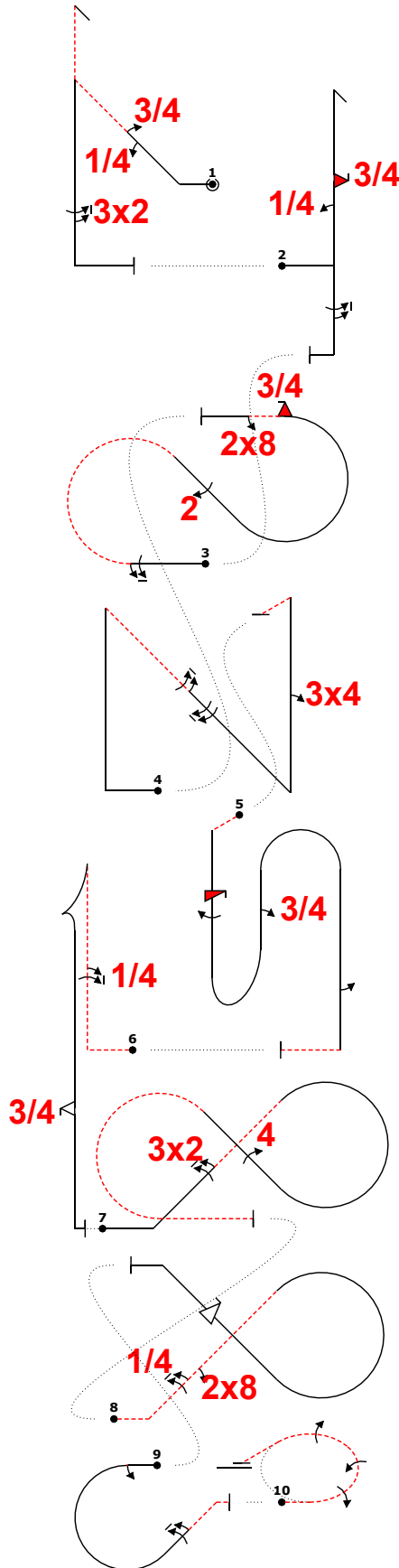

Power		
Fig	Aresti	K
1	5.3.2.1	24
	9.1.2.1	4
	9.1.2.3	8
	9.2.5.6	12
2	5.2.1.1	17
	9.1.1.1	6
	9.10.1.3	17
	9.1.5.6	10
3	7.5.6.1	16
	9.1.3.6	10
	9.2.4.4	9
	9.10.8.3	15
4	1.3.11.1	20
	9.1.4.6	10
	9.1.4.8	12
	9.4.1.3	12
5	8.8.2.4	19
	9.12.1.4	7
	9.1.5.4	8
	9.1.1.3	10
6	6.2.1.4	17
	9.1.1.5	14
	9.9.5.3	11
	7	7.8.7.1
9.2.2.6		14
9.4.2.4		13
8		7.3.1.2
	9.1.2.5	11
	9.8.2.1	5
	9.9.2.4	13
9	8.5.8.3	11
	9.1.3.2	4
	9.1.2.6	12
10	2.3.5.4	37
<b>Total K = 450</b>		
<b>(max K = 450)</b>		

Nicolas Durin Pilot  
EA330SC F-HODV A/C

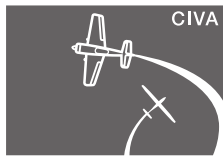

CIVA

FAI

AEROBATICS  
COMMISSION

Pilot ID

CIVA Unlimited Free Known

Form C

Flight #

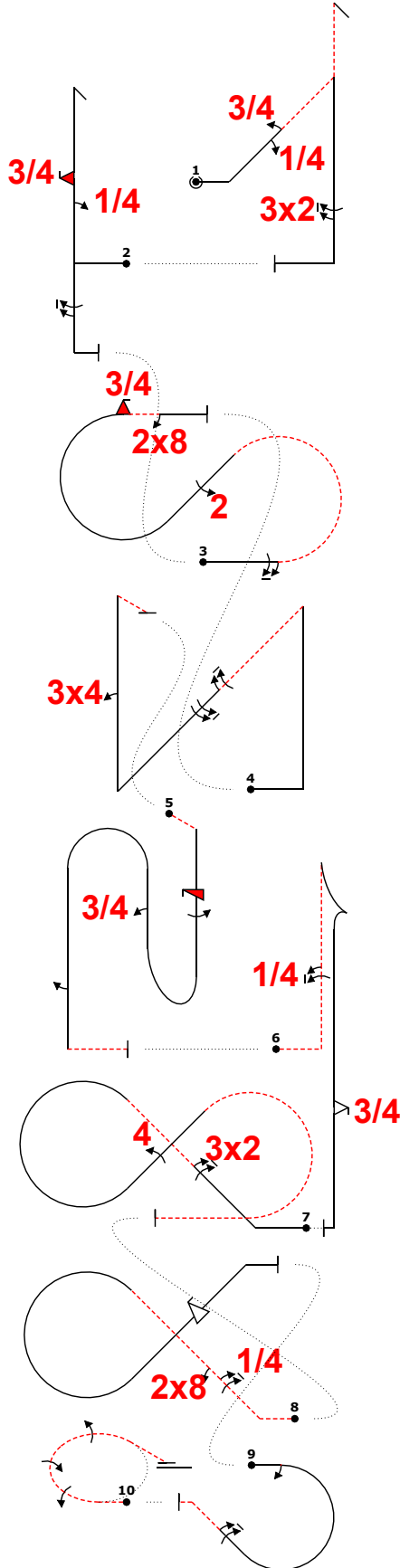

Power		
Fig	Aresti	K
1	5.3.2.1	24
	9.1.2.1	4
	9.1.2.3	8
	9.2.5.6	12
2 D	5.2.1.1	17
	9.1.1.1	6
	9.10.1.3	17
	9.1.5.6	10
3 C	7.5.6.1	16
	9.1.3.6	10
	9.2.4.4	9
	9.10.8.3	15
4	9.8.3.1	3
	1.3.11.1	20
	9.1.4.6	10
	9.1.4.8	12
5	9.4.1.3	12
	8.8.2.4	19
	9.12.1.4	7
	9.1.5.4	8
6 B	9.1.1.3	10
	9.1.5.2	4
	6.2.1.4	17
	9.1.1.5	14
7	9.9.5.3	11
	7.8.7.1	21
	9.2.2.6	14
	9.4.2.4	13
8 A	7.3.1.2	14
	9.1.2.5	11
	9.8.2.1	8
	9.9.2.4	13
9	8.5.8.3	11
	9.1.3.2	4
	9.1.2.6	12
	2.3.5.4	37
10 E		
<b>Total K = 450</b>		
(max K = 450)		

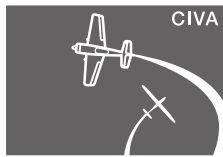

CIVA

FAI

AEROBATICS  
COMMISSION

Form B

Pilot ID

CIVA Unlimited Programme1

Flight #

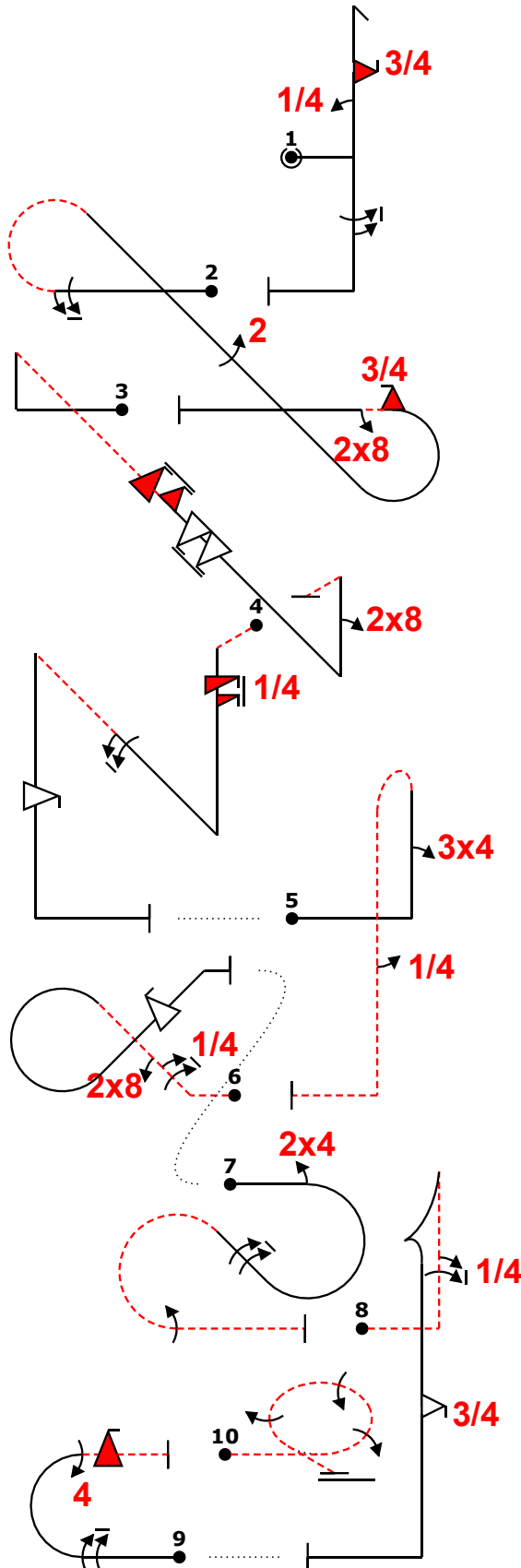
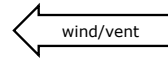

Power			
Fig	Aresti	K	
1 D	5.2.1.1	17	50
	9.1.1.1	6	
	9.10.1.3	17	
	9.1.5.6	10	
2 C	7.5.6.1	16	53
	9.1.3.6	10	
	9.2.4.4	9	
	9.10.8.3	15	
	9.8.3.1	3	
3	1.3.11.1	20	60
	9.10.4.6	16	
	9.9.4.8	17	
	9.8.1.1	7	
4	1.3.11.4	20	49
	9.12.1.5	6	
	9.1.2.6	12	
	9.9.5.4	11	
5	8.4.4.1	16	30
	9.4.1.3	12	
	9.1.5.1	2	
6 A	7.3.1.2	14	43
	9.1.2.5	11	
	9.8.2.1	5	
	9.9.2.4	13	
7	7.5.3.3	16	44
	9.4.3.2	5	
	9.1.2.8	15	
	9.1.3.4	8	
8 B	6.2.1.4	17	42
	9.1.1.5	14	
	9.9.5.3	11	
9	7.2.1.1	6	42
	9.1.3.8	12	
	9.4.3.4	11	
	9.10.3.4	13	
10 E	2.3.5.4	37	37
<b>Total K = 450</b> (max K = 450)			

Louis Pilot  
E330SC FHMKF  
A/C

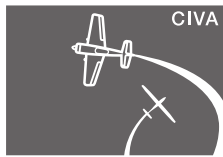

CIVA

FAI

AEROBATICS  
COMMISSION

Form C

Pilot ID

CIVA Unlimited Programme1

Flight #

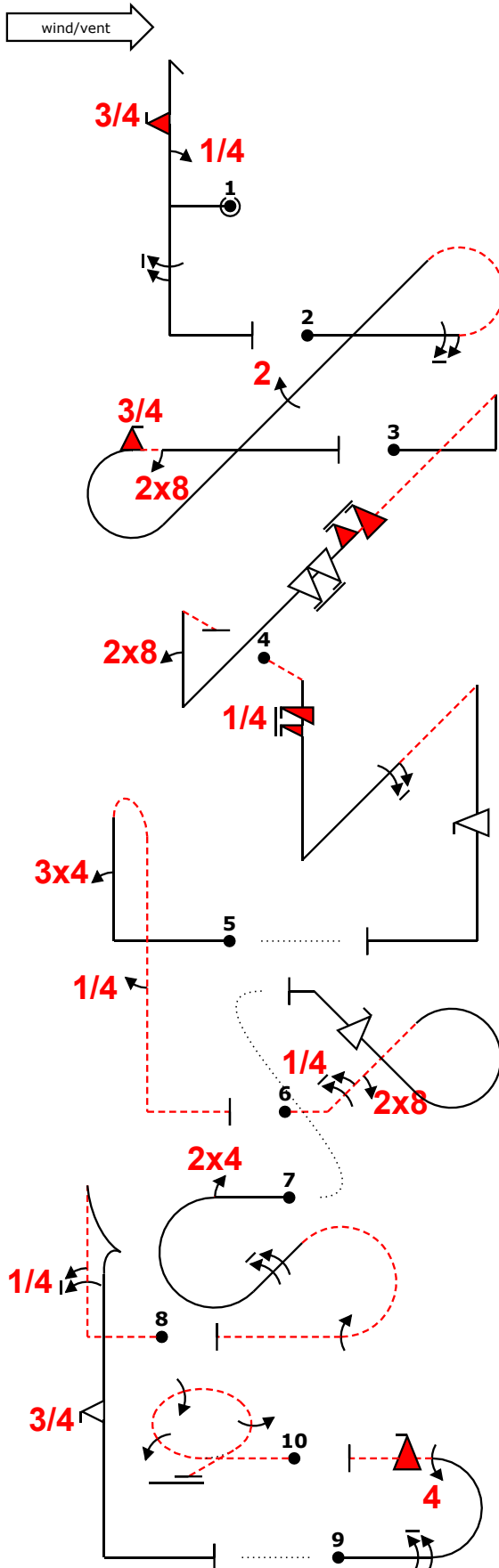

Power			
Fig	Aresti	K	
1 D	5.2.1.1	17	50
	9.1.1.1	6	
	9.10.1.3	17	
	9.1.5.6	10	
2 C	7.5.6.1	16	53
	9.1.3.6	10	
	9.2.4.4	9	
	9.10.8.3	15	
	9.8.3.1	3	
3	1.3.11.1	20	60
	9.10.4.6	16	
	9.9.4.8	17	
	9.8.1.1	7	
4	1.3.11.4	20	49
	9.12.1.5	6	
	9.1.2.6	12	
	9.9.5.4	11	
5	8.4.4.1	16	30
	9.4.1.3	12	
	9.1.5.1	2	
6 A	7.3.1.2	14	43
	9.1.2.5	11	
	9.8.2.1	5	
	9.9.2.4	13	
7	7.5.3.3	16	44
	9.4.3.2	5	
	9.1.2.8	15	
	9.1.3.4	8	
8 B	6.2.1.4	17	42
	9.1.1.5	14	
	9.9.5.3	11	
9	7.2.1.1	6	42
	9.1.3.8	12	
	9.4.3.4	11	
	9.10.3.4	13	
10 E	2.3.5.4	37	37
<b>Total K = 450</b> (max K = 450)			

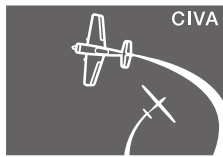

CIVA

FAI

AEROBATICS  
COMMISSION

Pilot ID

CIVA Unlimited Programme1

Form B

Flight #

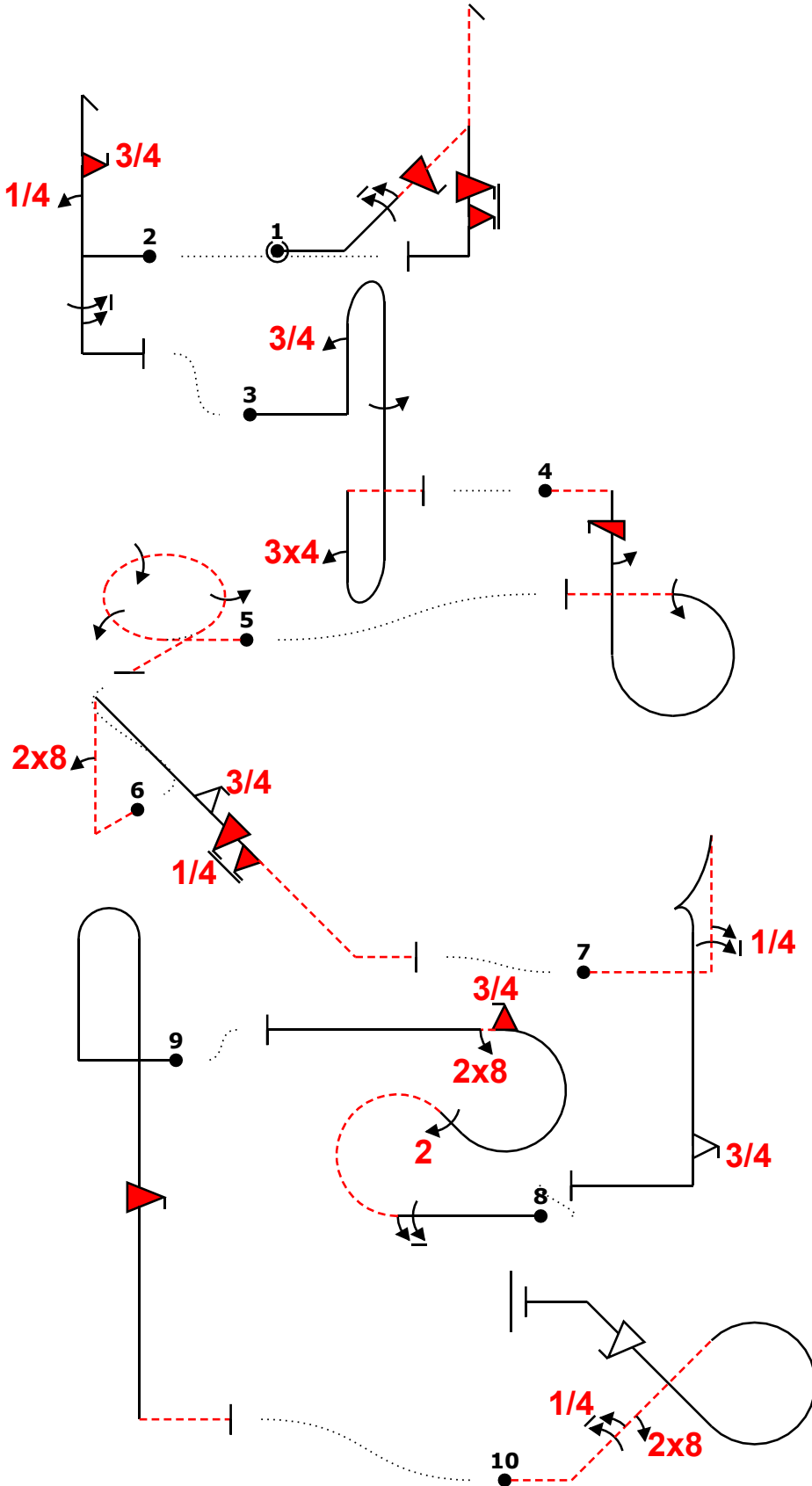
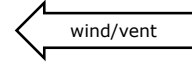

Power			
Fig	Aresti	K	
1	5.3.2.1	24	67
	9.1.2.6	12	
	9.10.2.4	15	
	9.10.5.6	16	
2 D	5.2.1.1	17	50
	9.1.1.1	6	
	9.10.1.3	17	
	9.1.5.6	10	
3	8.8.1.1	18	48
	9.1.1.3	10	
	9.1.5.4	8	
	9.4.1.3	12	
4	8.6.1.4	12	31
	9.12.1.4	7	
	9.1.5.2	4	
	9.1.3.4	8	
5 E	2.3.5.4	37	37
6	1.2.7.2	17	50
	9.8.1.1	7	
	9.9.4.3	11	
	9.10.4.5	15	
7 B	6.2.1.4	17	42
	9.1.1.5	14	
	9.9.5.3	11	
8 C	7.5.6.1	16	53
	9.1.3.6	10	
	9.2.4.4	9	
	9.10.8.3	15	
	9.8.3.1	3	
9	8.4.2.1	14	29
	9.10.10.4	15	
10 A	7.3.1.2	14	43
	9.1.2.5	11	
	9.8.2.1	5	
	9.9.2.4	13	
<b>Total K = 450</b> (max K = 450)			

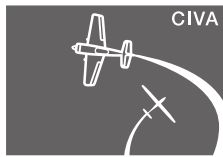

FAI

AEROBATICS  
COMMISSION

Pilot ID

CIVA Unlimited Programme1

Form C

Flight #

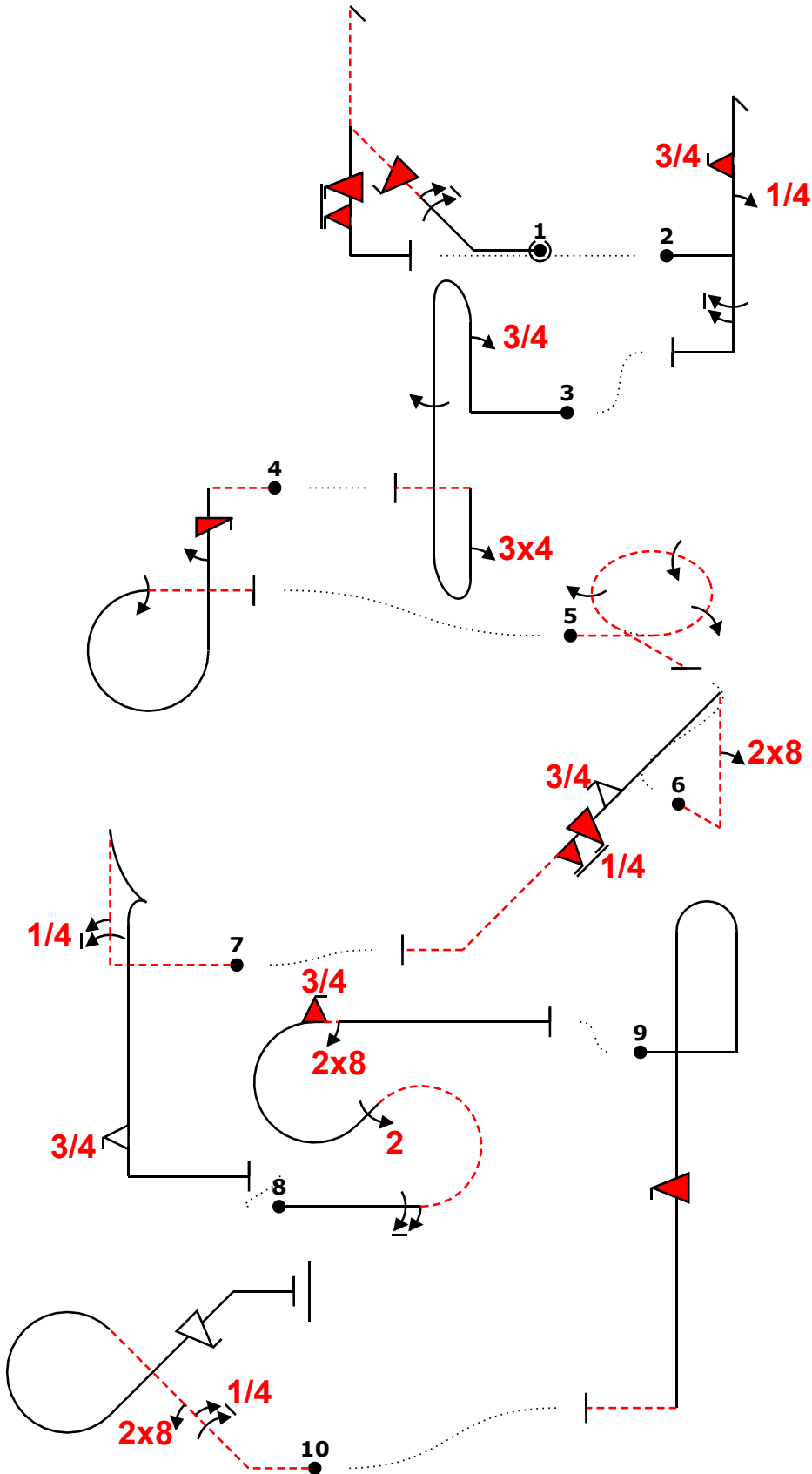
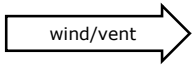

Power			
Fig	Aresti	K	
1	5.3.2.1	24	67
	9.1.2.6	12	
	9.10.2.4	15	
	9.10.5.6	16	
2 D	5.2.1.1	17	50
	9.1.1.1	6	
	9.10.1.3	17	
	9.1.5.6	10	
3	8.8.1.1	18	48
	9.1.1.3	10	
	9.1.5.4	8	
	9.4.1.3	12	
4	8.6.1.4	12	31
	9.12.1.4	7	
	9.1.5.2	4	
	9.1.3.4	8	
5 E	2.3.5.4	37	37
6	1.2.7.2	17	50
	9.8.1.1	7	
	9.9.4.3	11	
	9.10.4.5	15	
7 B	6.2.1.4	17	42
	9.1.1.5	14	
	9.9.5.3	11	
8 C	7.5.6.1	16	53
	9.1.3.6	10	
	9.2.4.4	9	
	9.10.8.3	15	
	9.8.3.1	3	
9	8.4.2.1	14	29
	9.10.10.4	15	
10 A	7.3.1.2	14	43
	9.1.2.5	11	
	9.8.2.1	5	
	9.9.2.4	13	
<b>Total K = 450</b> (max K = 450)			

Jonathan Vincent Pilot  
EA 300 F-HMTM A/C

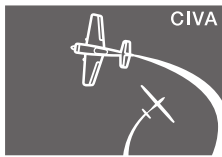

CIVA

FAI

AEROBATICS COMMISSION

Pilot ID

CIVA Unlimited Free Known

Form B

Flight #

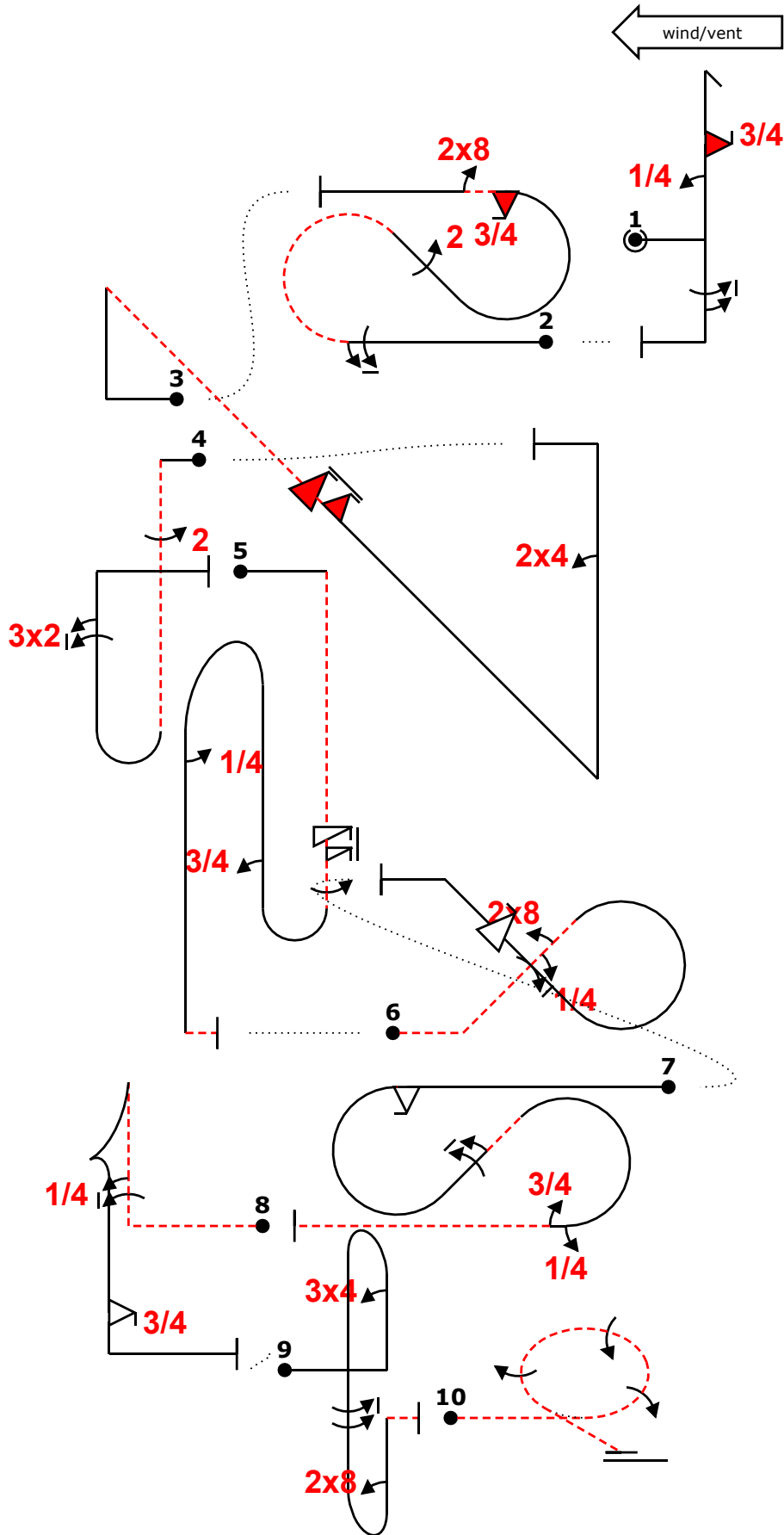

BUSQUE Pilot  
 Extra 330 SC F-TGCJ A/C

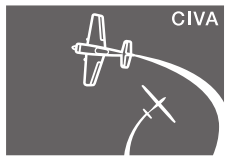

FAI

AEROBATICS  
COMMISSION

Pilot ID

CIVA Unlimited Free Known

Form C

Flight #

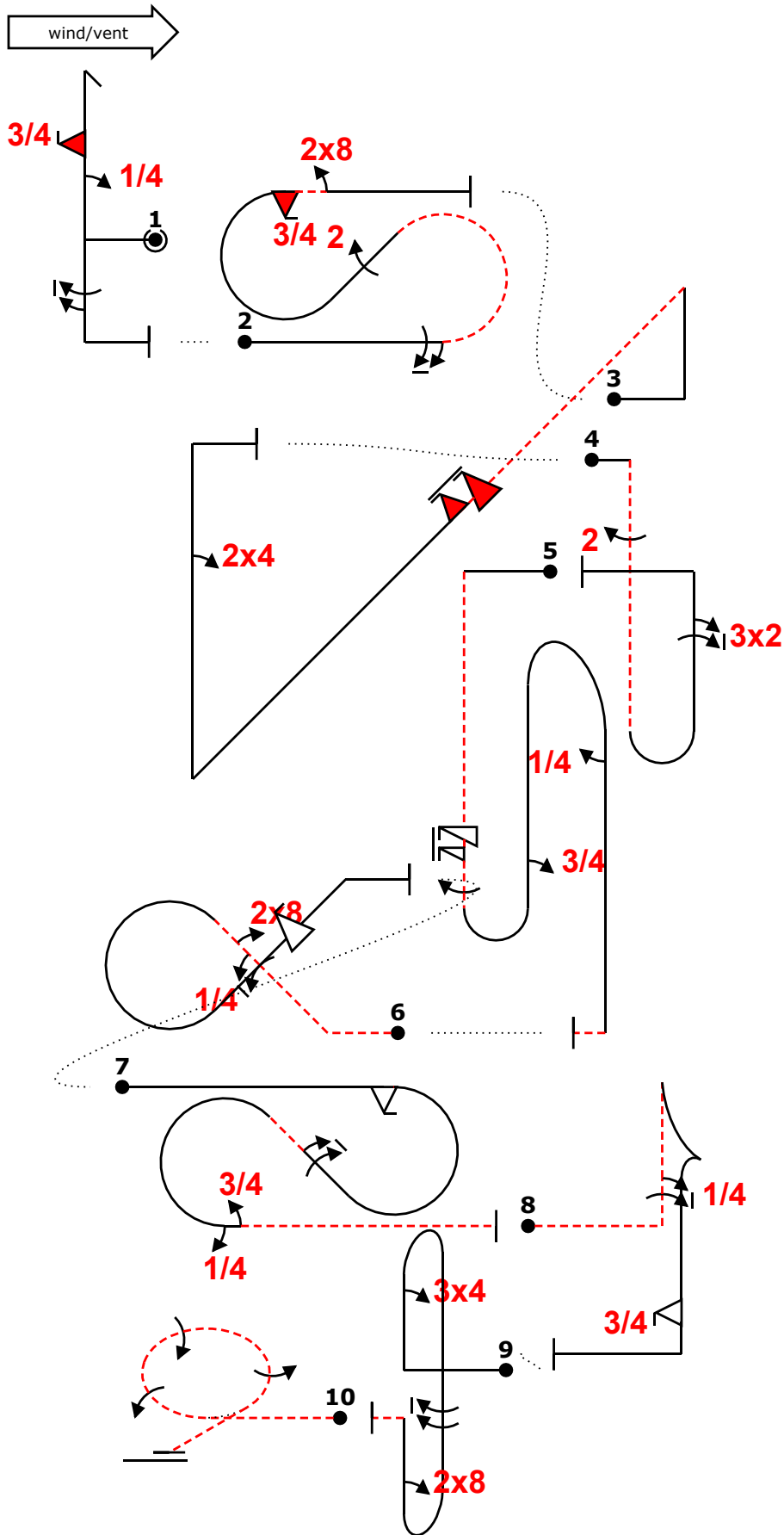

BUSQUE Pilot  
Extra 330 SC F-TGCJ  
A/C



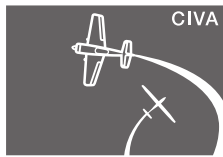

CIVA

FAI

AEROBATICS  
COMMISSION

BRIARE 082020

Form B

Pilot ID

CIVA Unlimited Programme1

Flight #

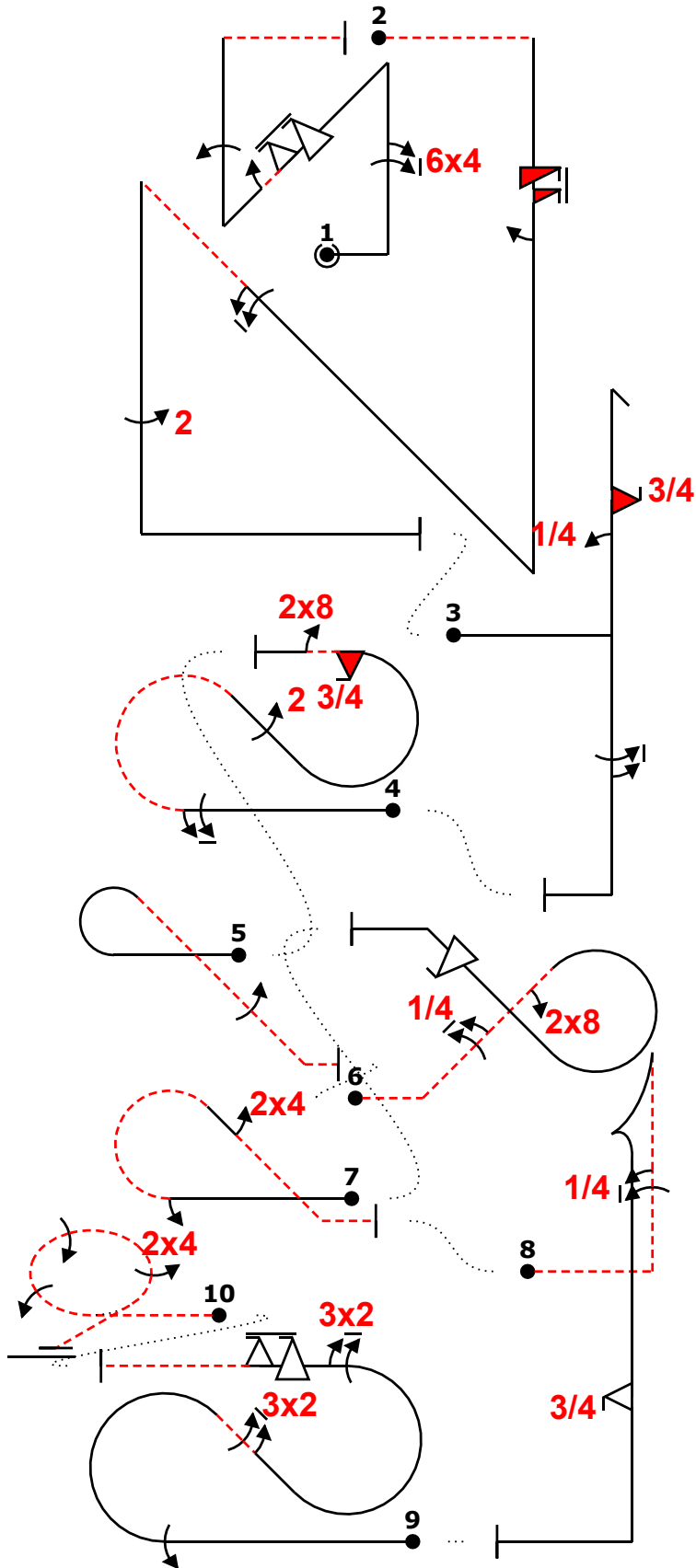
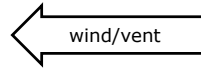

CHESNEAU Pilot  
 SUKHOI 26 HA HUR A/C

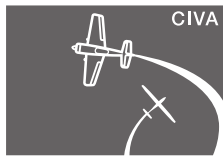

CIVA

FAI

AEROBATICS  
COMMISSION

BRIARE 082020

Form C

Pilot ID

Flight #

CIVA Unlimited Programme1

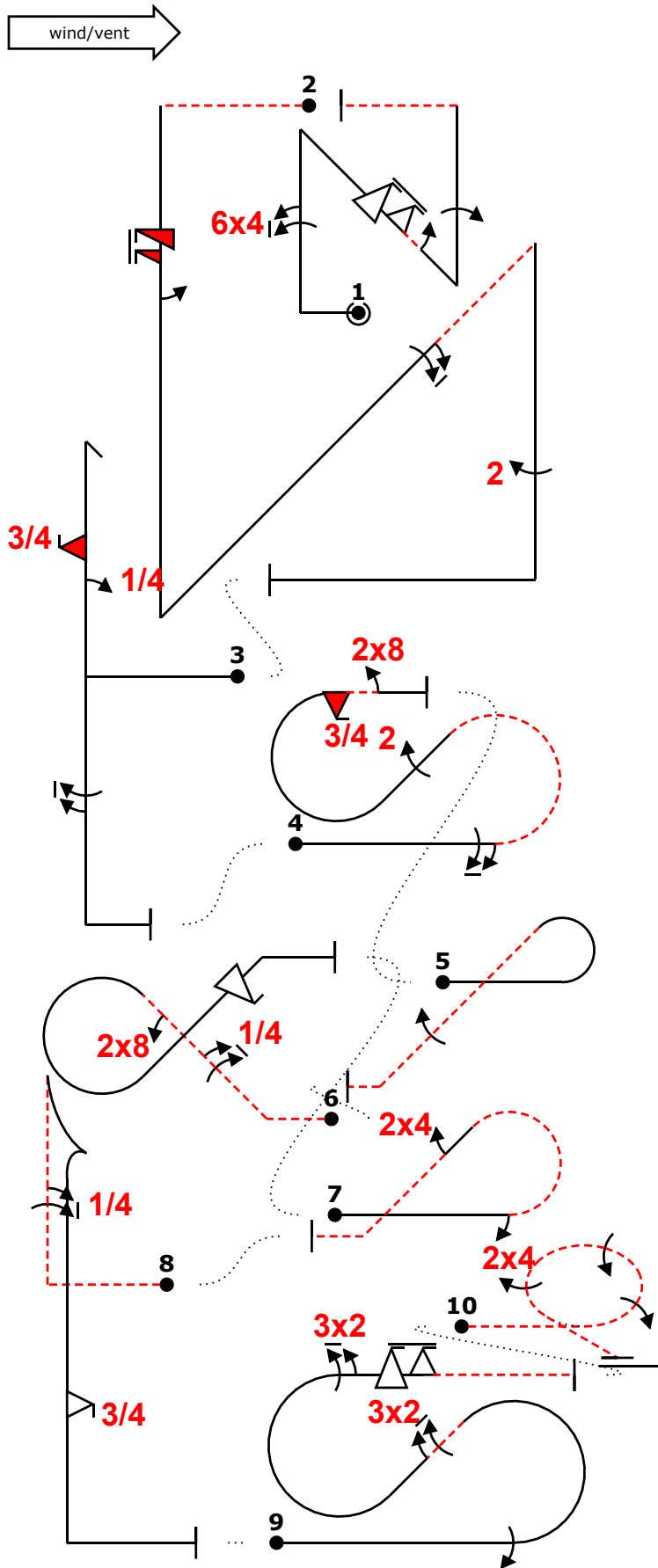

CHESNEAU Pilot  
 SUKHOI 26 HA HUR A/C

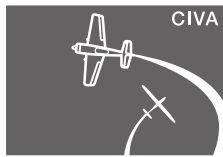

CIVA

FAI

AEROBATICS  
COMMISSION

Form B

Pilot ID

CIVA Unlimited Free Known

Flight #

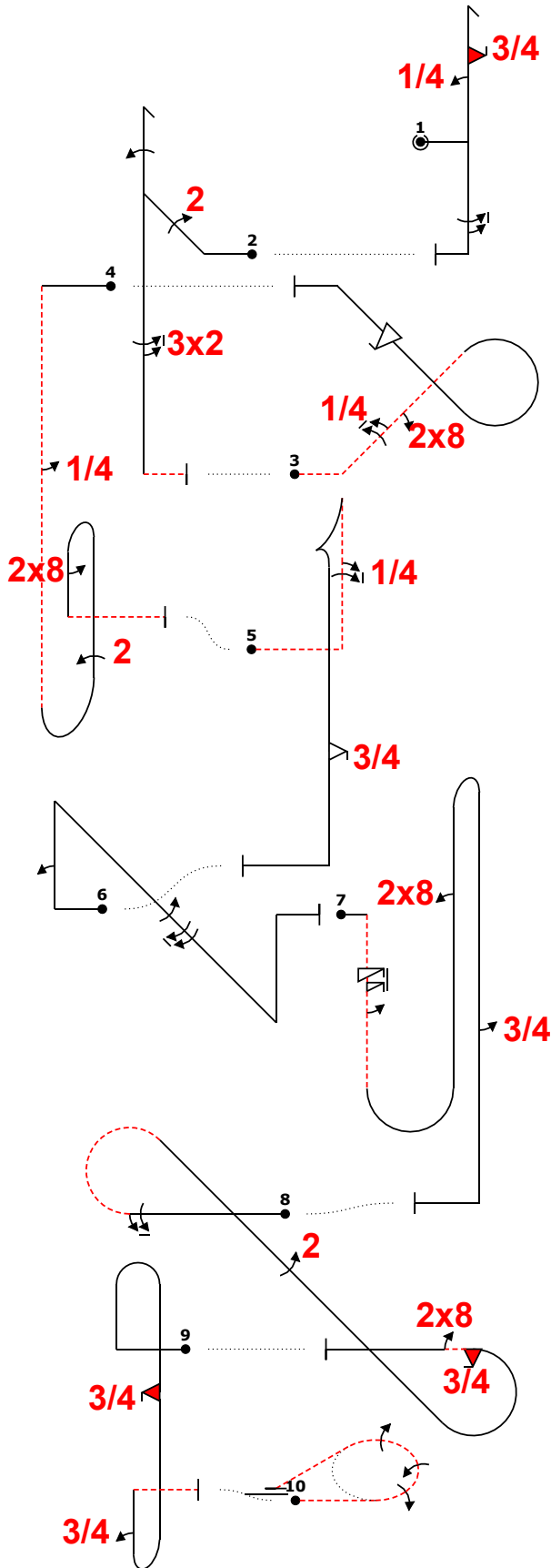
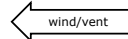

Power		
Fig	Aresti	K
1	5.2.1.1	17
	9.1.1.1	6
	9.10.1.3	17
	9.1.5.6	10
2	5.3.1.3	20
	9.2.2.4	11
	9.1.1.4	12
	9.2.5.6	12
3	7.3.1.2	14
	9.1.2.5	11
	9.8.2.1	5
	9.9.2.4	13
4	8.8.7.3	20
	9.1.5.1	2
	9.2.1.4	13
	9.8.5.1	3
5	6.2.1.4	17
	9.1.1.5	14
	9.9.5.3	11
6	1.3.13.1	22
	9.1.1.2	8
	9.1.4.4	8
	9.1.4.8	12
7	8.8.8.3	19
	9.11.1.6	3
	9.1.5.2	4
	9.8.1.1	7
8	7.5.6.1	16
	9.1.3.6	10
	9.2.4.4	9
	9.10.8.3	15
9	8.8.1.1	18
	9.10.10.3	15
	9.1.1.3	10
	2.3.5.4	37
10	2.3.5.4	37
<b>Total K = 450</b>		
(max K = 450)		

Flo Pilot  
Extra CI  
A/C

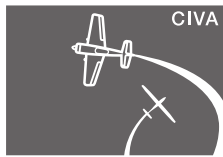

CIVA

FAI

AEROBATICS  
COMMISSION

Form C

Pilot ID

CIVA Unlimited Free Known

Flight #

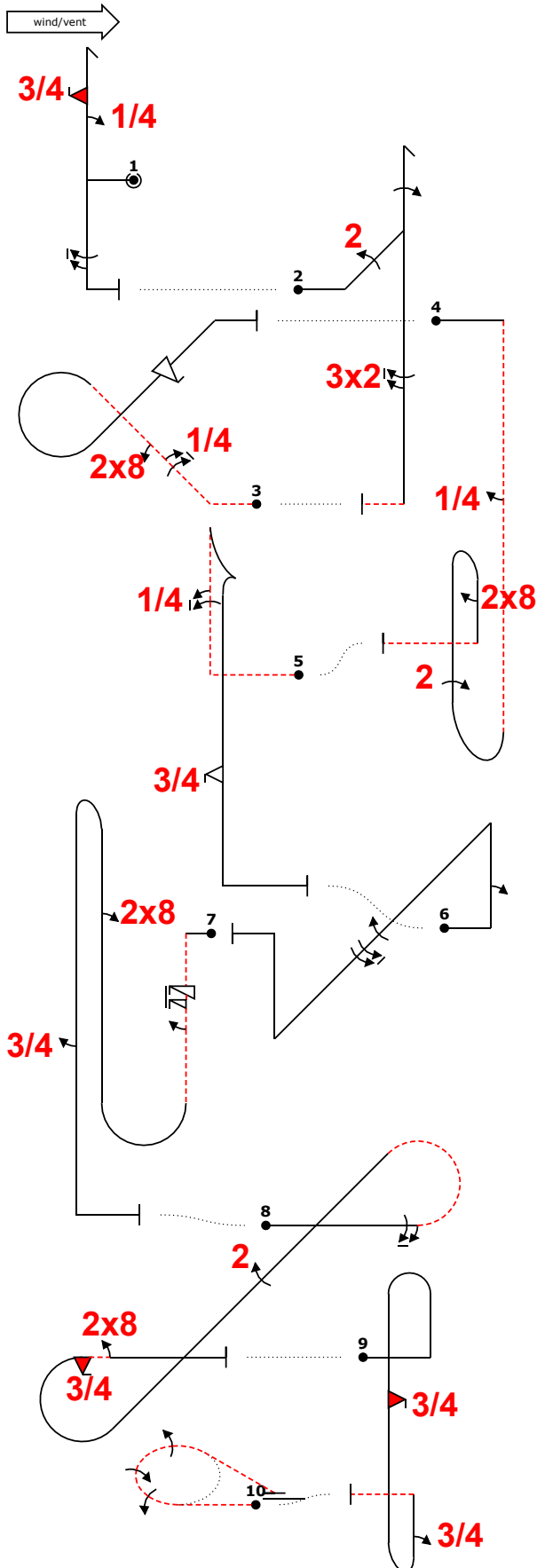

Power		
Fig	Aresti	K
1 D	5.2.1.1	17
	9.1.1.1	6
	9.10.1.3	17
	9.1.5.6	10
2	5.3.1.3	20
	9.2.2.4	11
	9.1.1.4	12
	9.2.5.6	12
3 A	7.3.1.2	14
	9.1.2.5	11
	9.8.2.1	5
	9.9.2.4	13
4	8.8.7.3	20
	9.1.5.1	2
	9.2.1.4	13
	9.8.5.1	3
5 B	6.2.1.4	17
	9.1.1.5	14
	9.9.5.3	11
6	1.3.13.1	22
	9.1.1.2	8
	9.1.4.4	8
	9.1.4.8	12
7	8.8.8.3	19
	9.1.1.6	3
	9.1.5.2	4
	9.8.1.1	7
	9.1.5.3	6
8 C	7.5.6.1	16
	9.1.3.6	10
	9.2.4.4	9
	9.10.8.3	15
	9.8.3.1	3
9	8.8.1.1	18
	9.10.10.3	15
	9.1.1.3	10
10 E	2.3.5.4	37
<b>Total K = 450</b>		
(max K = 450)		

Flo Pilot  
Extra CI  
A/C

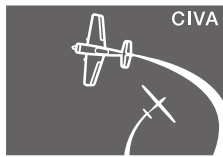

CIVA

FAI

AEROBATICS  
COMMISSION

Form B

Pilot ID

CIVA Unlimited Free Known

Flight #

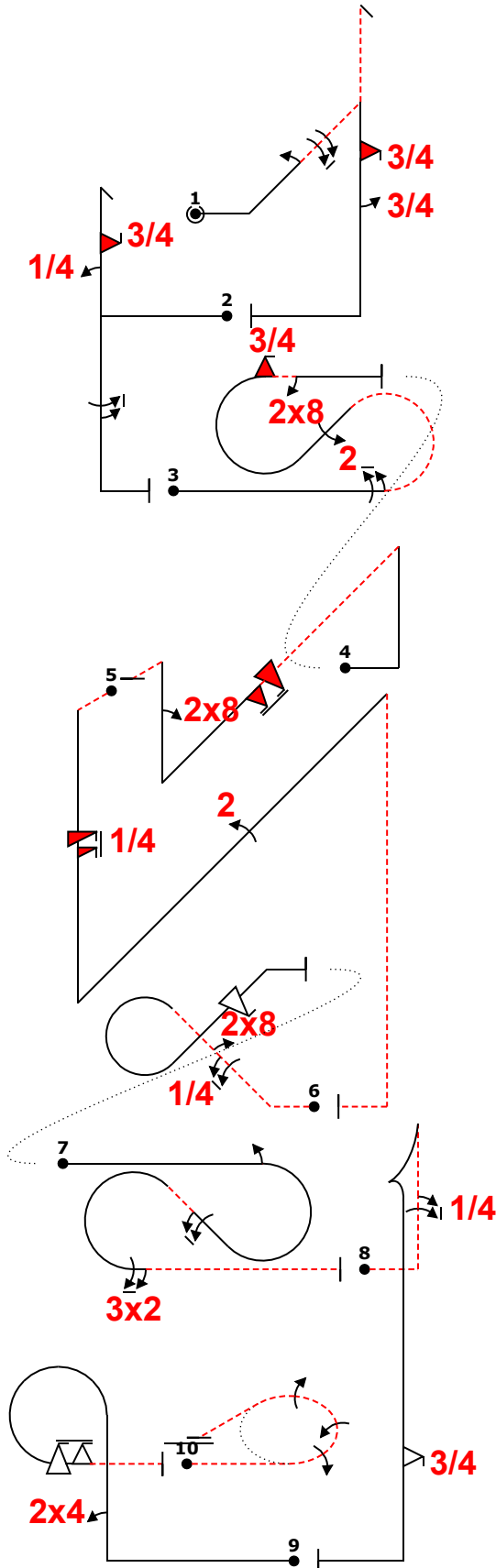
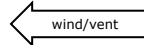

Power			
Fig	Aresti	K	
1	5.3.2.1	24	64
	9.1.2.2	6	
	9.1.2.8	15	
	9.10.5.3	13	
	9.1.5.3	6	
2 D	5.2.1.1	17	50
	9.1.1.1	6	
	9.10.1.3	17	
	9.1.5.6	10	
3 C	7.5.6.1	16	53
	9.1.3.6	10	
	9.2.4.4	9	
	9.10.8.3	15	
	9.8.3.1	3	
4	1.3.11.1	20	43
	9.10.4.6	16	
	9.8.1.1	7	
5	1.3.9.4	23	40
	9.12.1.5	6	
	9.2.2.4	11	
6 A	7.3.1.2	14	43
	9.1.2.5	11	
	9.8.2.1	5	
	9.9.2.4	13	
7	7.5.8.3	15	43
	9.1.3.2	4	
	9.1.2.6	12	
	9.2.3.6	12	
8 B	6.2.1.4	17	42
	9.1.1.5	14	
	9.9.5.3	11	
9	8.6.2.1	12	35
	9.4.1.2	9	
	9.9.3.6	14	
10 E	2.3.5.4	37	37
<b>Total K = 450</b>		<b>(max K = 450)</b>	

Leboulanger Pilot  
FHRA A/C

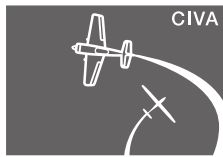

CIVA

FAI

AEROBATICS  
COMMISSION

Form C

Pilot ID

CIVA Unlimited Free Known

Flight #

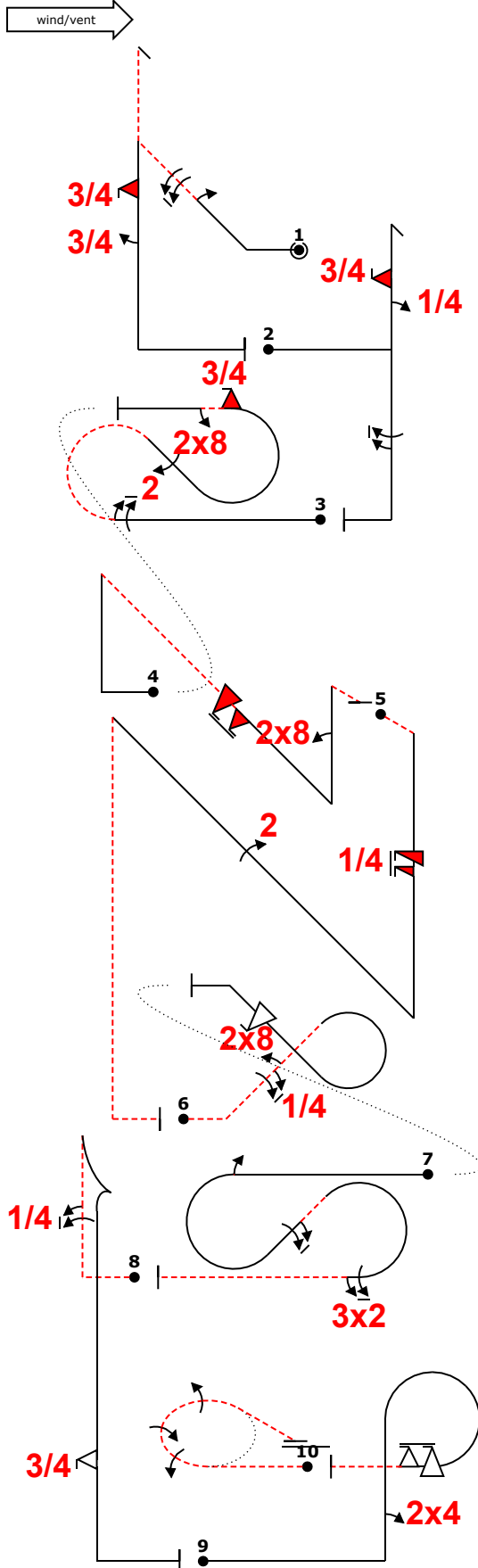

Power			
Fig	Aresti	K	
1	5.3.2.1	24	64
	9.1.2.2	6	
	9.1.2.8	15	
	9.10.5.3	13	
	9.1.5.3	6	
2 D	5.2.1.1	17	50
	9.1.1.1	6	
	9.10.1.3	17	
	9.1.5.6	10	
3 C	7.5.6.1	16	53
	9.1.3.6	10	
	9.2.4.4	9	
	9.10.8.3	15	
	9.8.3.1	3	
4	1.3.11.1	20	43
	9.10.4.6	16	
	9.8.1.1	7	
5	1.3.9.4	23	40
	9.12.1.5	6	
	9.2.2.4	11	
6 A	7.3.1.2	14	43
	9.1.2.5	11	
	9.8.2.1	5	
	9.9.2.4	13	
7	7.5.8.3	15	43
	9.1.3.2	4	
	9.1.2.6	12	
	9.2.3.6	12	
8 B	6.2.1.4	17	42
	9.1.1.5	14	
	9.9.5.3	11	
9	8.6.2.1	12	35
	9.4.1.2	9	
	9.9.3.6	14	
10 E	2.3.5.4	37	37
<b>Total K = 450</b>		<b>(max K = 450)</b>	

Leboulanger Pilot  
FHRA A/C

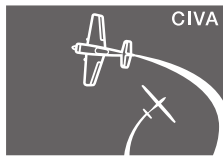

CIVA

FAI

AEROBATICS  
COMMISSION

# CF1 / CHATEAUROUX

Form B

Pilot ID

Flight #

CIVA Unlimited Free Known

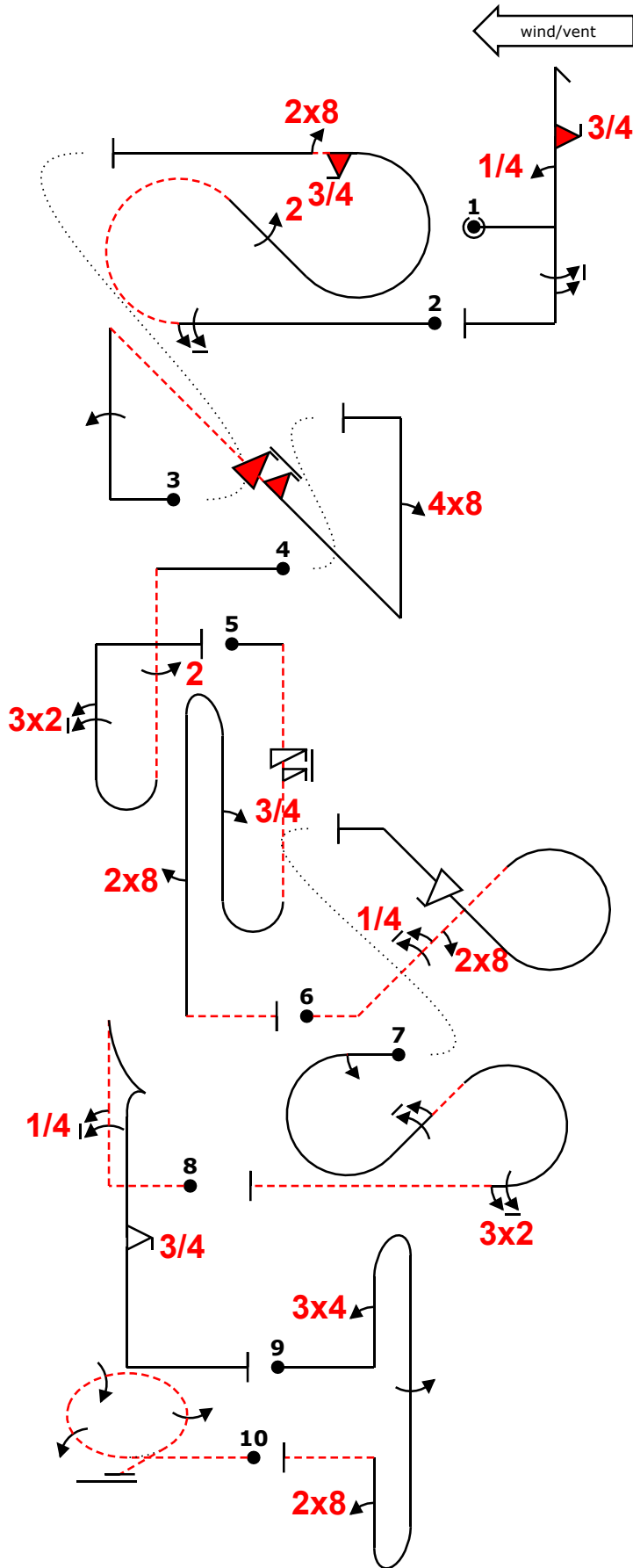

BERNEYRON Pilot  
EXTRA330SC F-TGCJ A/C

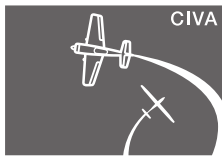

CIVA

FAI

AEROBATICS  
COMMISSION

CF1 / CHATEAUROUX

Form C

Pilot ID

CIVA Unlimited Free Known

Flight #

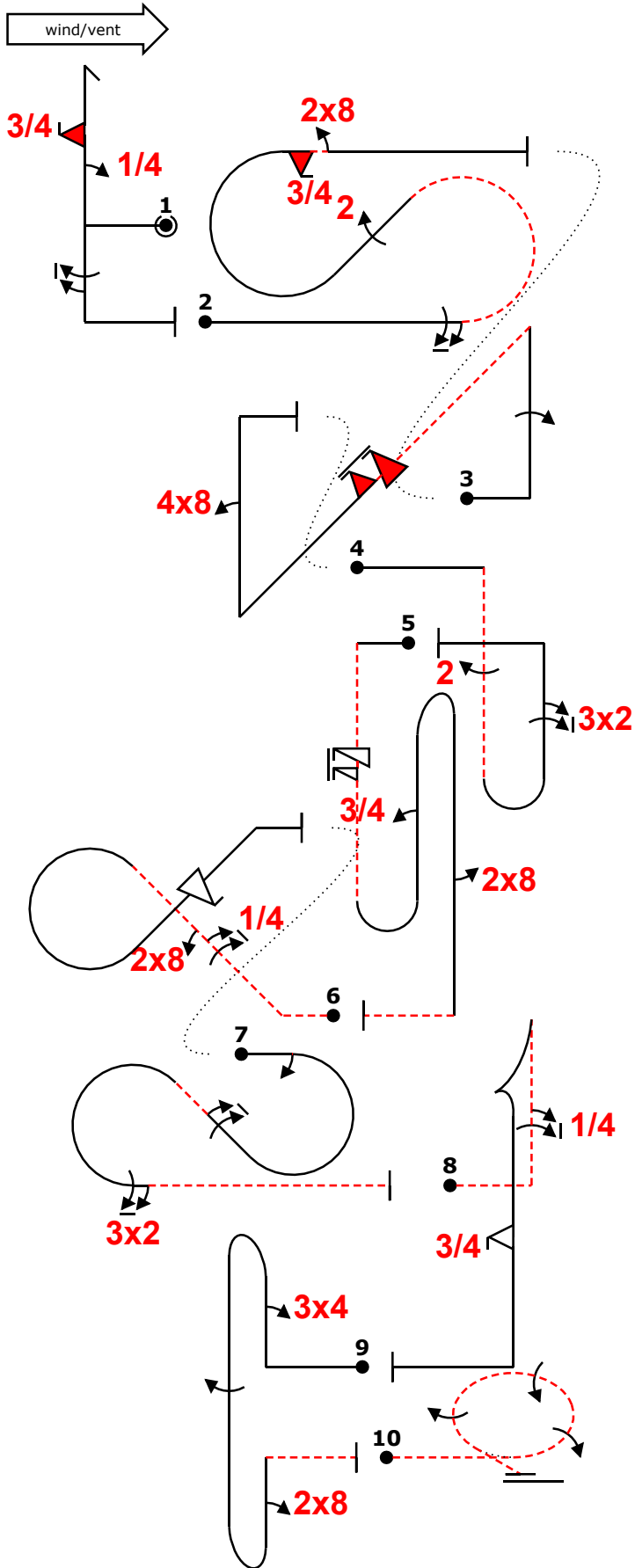

BERNEYRON Pilot  
EXTRA330SC F-TGCJ  
A/C



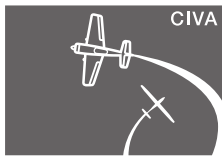

CIVA

FAI

AEROBATICS  
COMMISSION

Pilot ID

CIVA Unlimited Programme1

Form B

Flight #

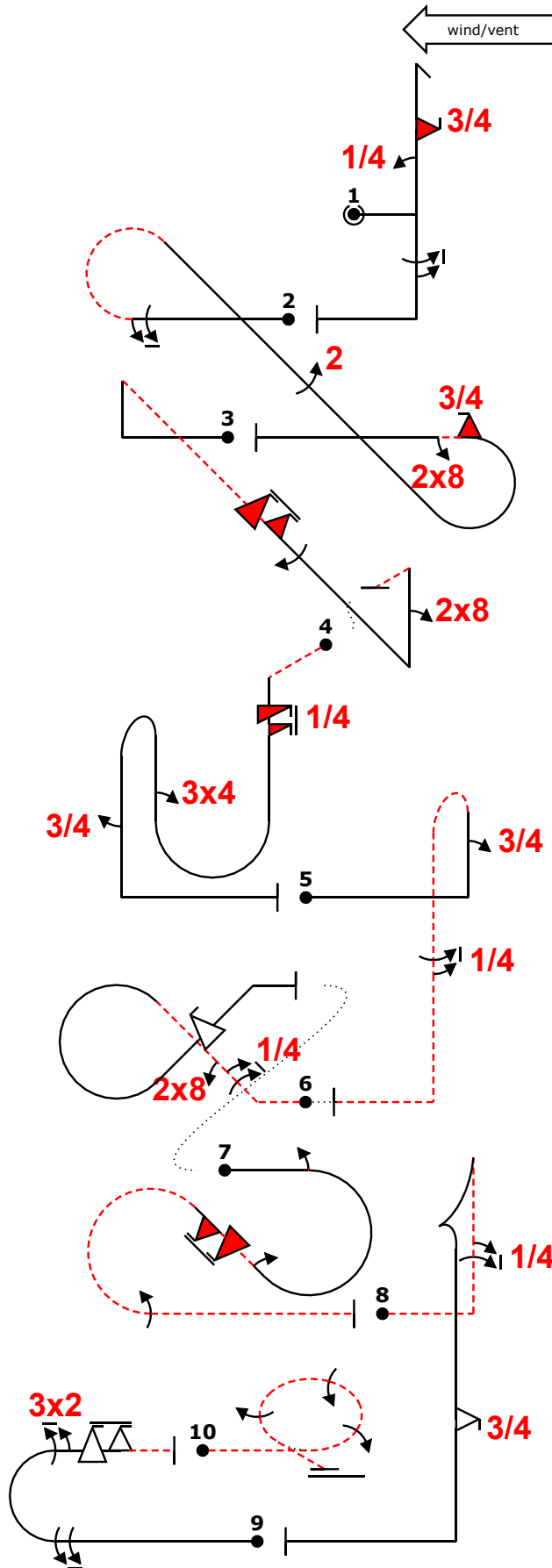

BRAGEOT Pilot  
EXTRA330 F-HMKF A/C

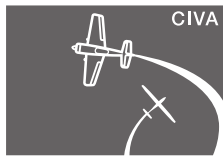

CIVA

FAI

AEROBATICS  
COMMISSION

Pilot ID

CIVA Unlimited Programme1

Form C

Flight #

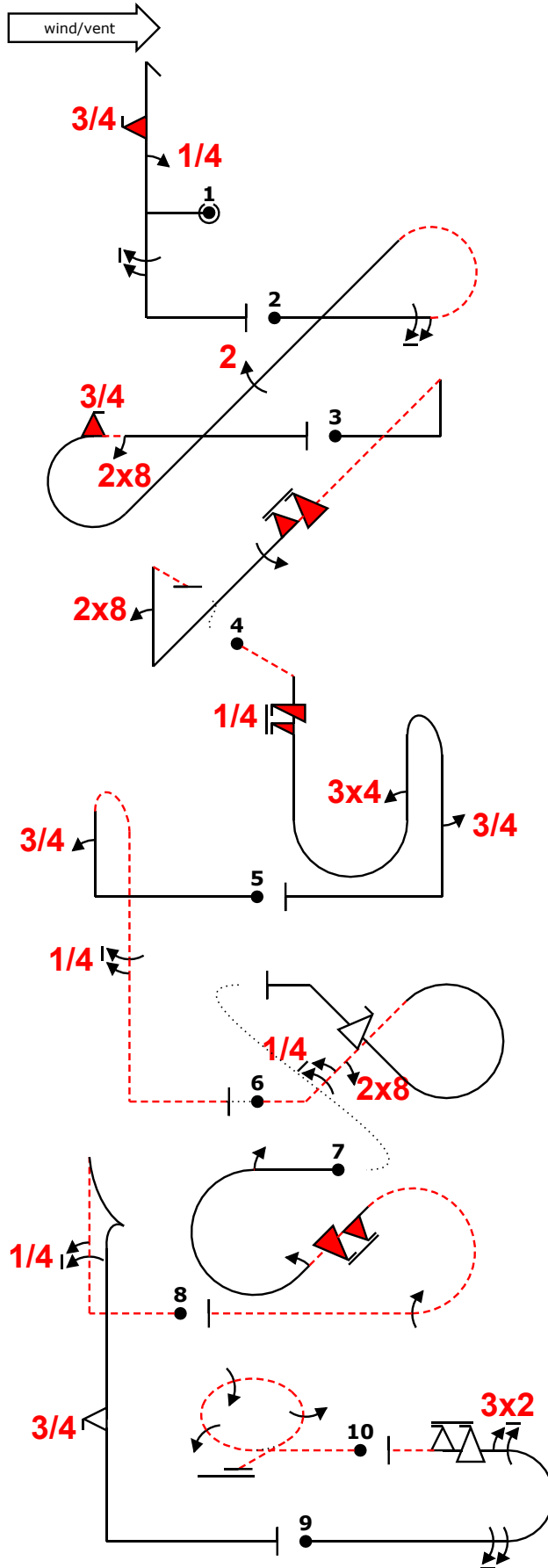

BRAGEOT Pilot  
EXTRA330 F-HMKF A/C

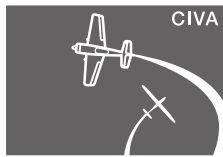

CIVA

FAI

AEROBATICS  
COMMISSION

Pilot ID

CIVA Unlimited Programme1

Form B

Flight #

wind/vent ←

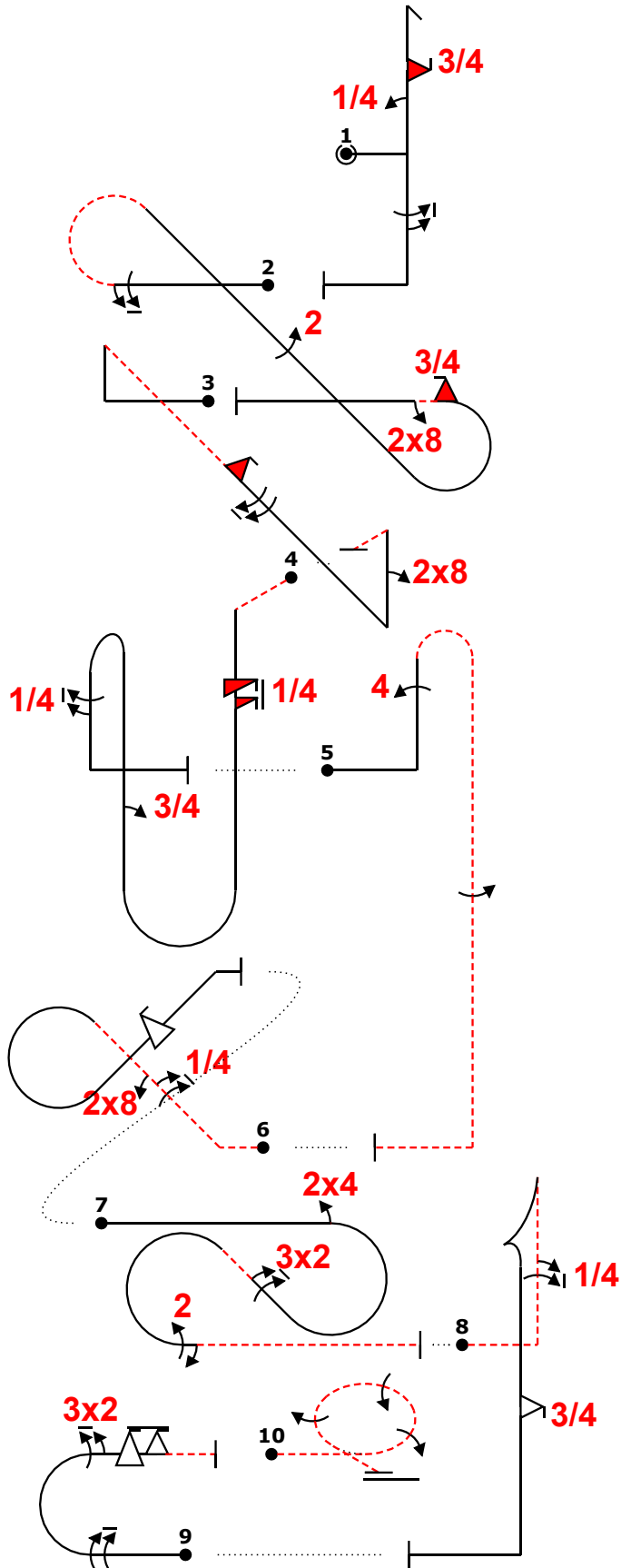

BLANCHARD Pilot  
E330SC F-HODV A/C

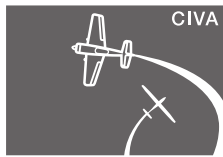

CIVA

FAI

AEROBATICS  
COMMISSION

Pilot ID

CIVA Unlimited Programme1

Form C

Flight #

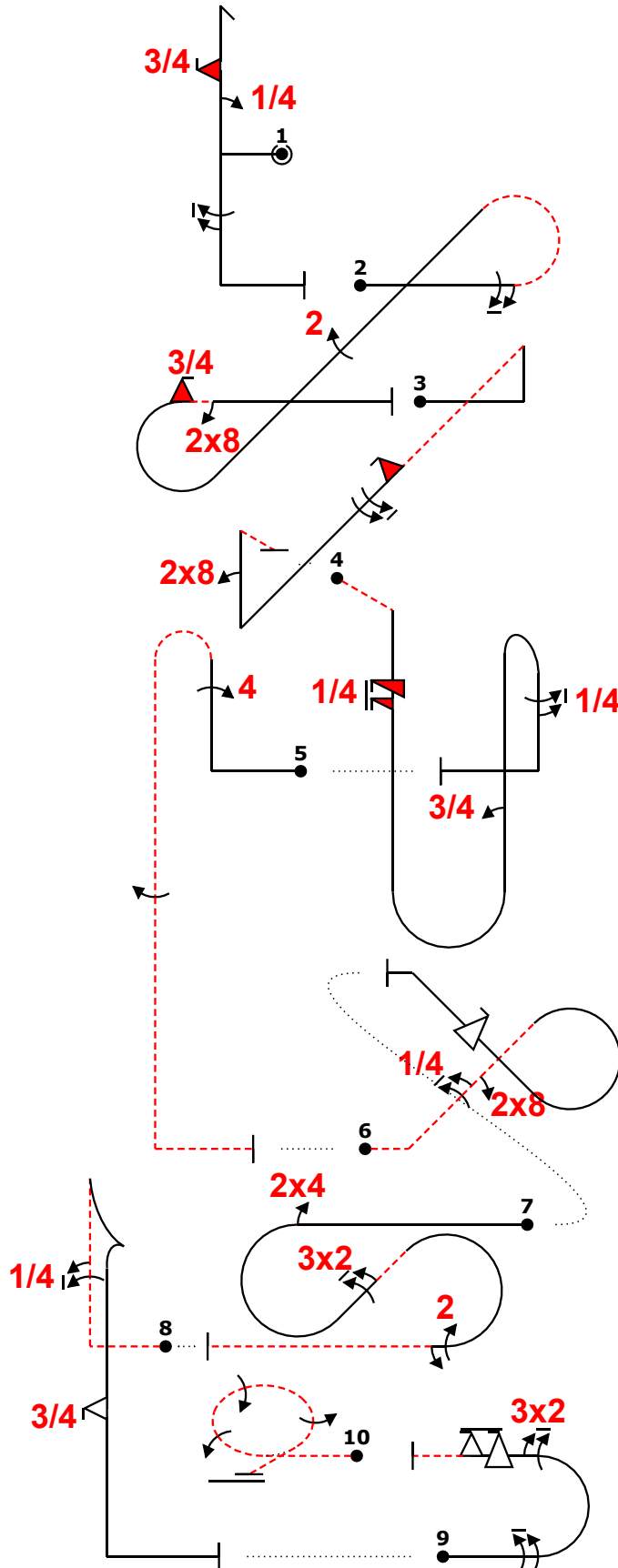

**BLANCHARD** Pilot  
**E330SC F-HODV** A/C

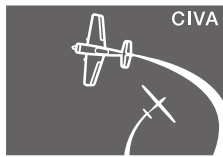

CIVA

FAI

AEROBATICS  
COMMISSION

Villers Sep 2020

Form B

Pilot ID

CIVA Unlimited Programme1

Flight #

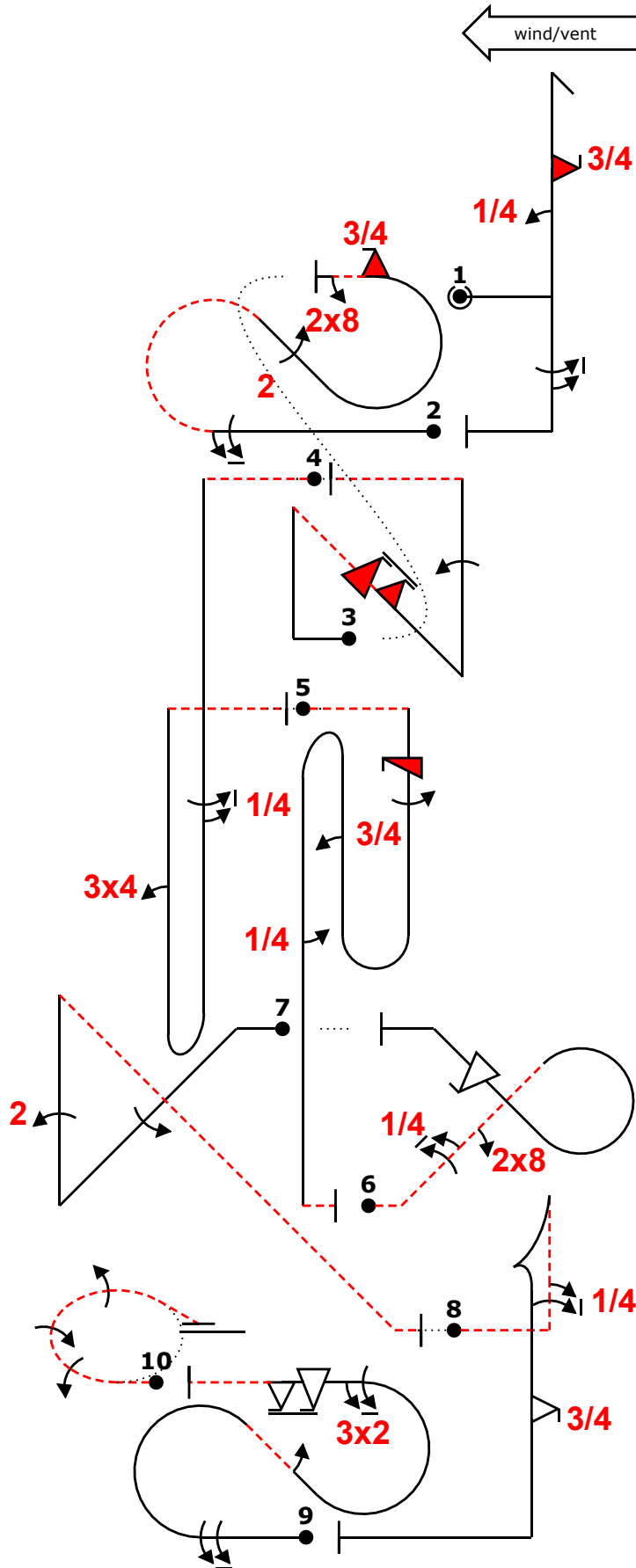

Melanie Astles Pilot  
 Extra 330 SC F-HUSA A/C

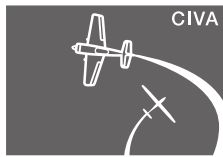

CIVA

FAI

AEROBATICS  
COMMISSION

Villers Sep 2020

Form C

Pilot ID

CIVA Unlimited Programme1

Flight #

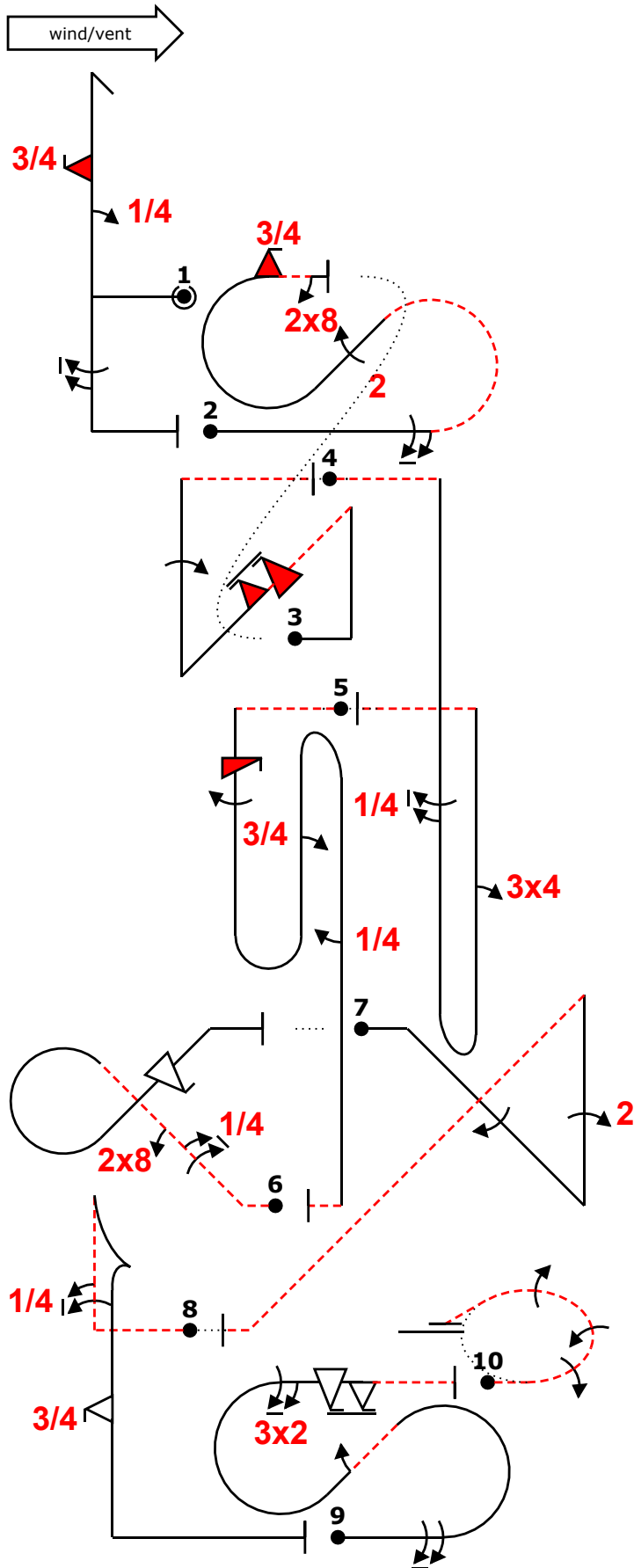

Melanie Astles Pilot  
 Extra 330 SC F-HUSA A/C

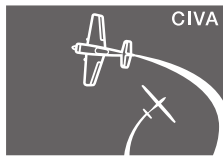

CIVA

FAI

AEROBATICS  
COMMISSION

CF1 2020

Form B

Pilot ID

CIVA Unlimited Programme1

Flight #

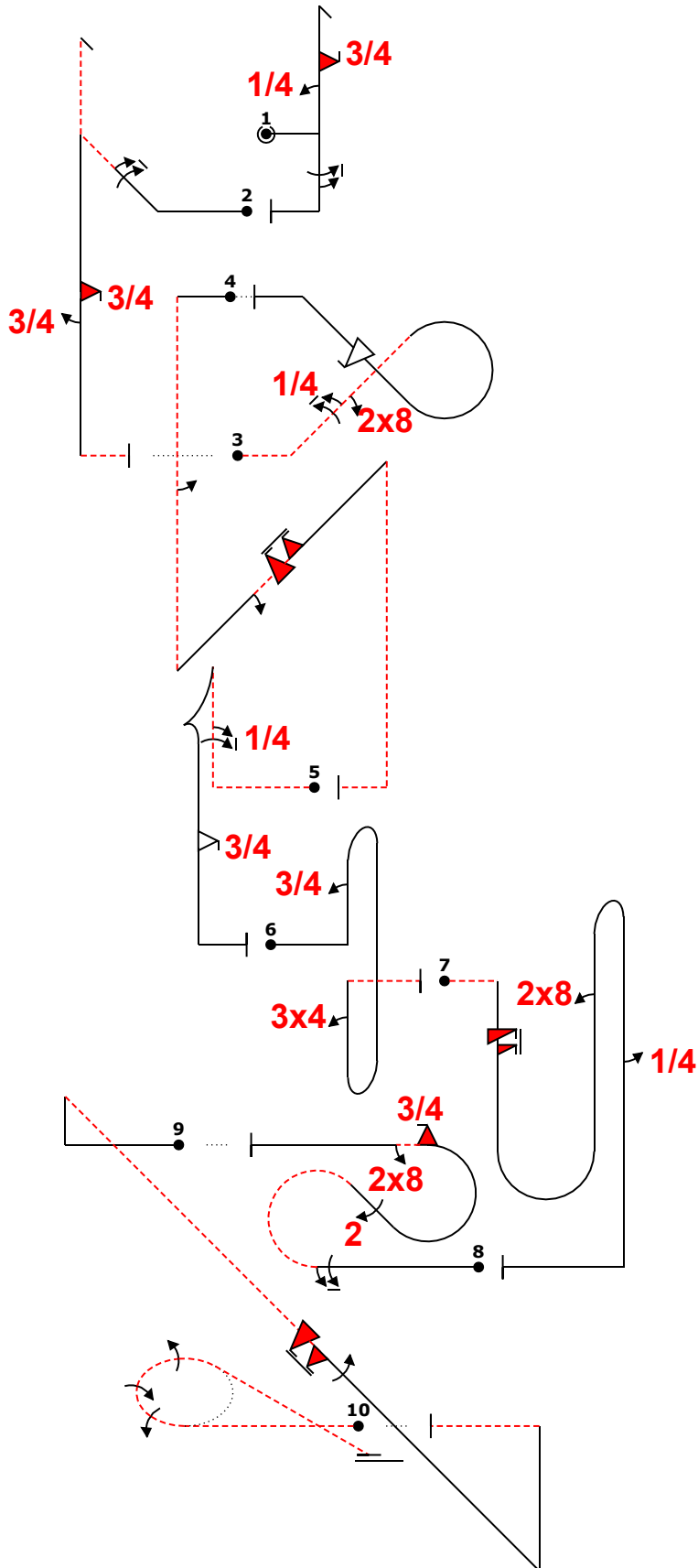
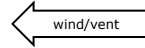

Power			
Fig	Aresti	K	
1 D	5.2.1.1	17	50
	9.1.1.1	6	
	9.10.1.3	17	
	9.1.5.6	10	
2	5.3.2.3	25	56
	9.1.2.6	12	
	9.10.5.3	13	
	9.1.5.3	6	
3 A	7.3.1.2	14	43
	9.1.2.5	11	
	9.8.2.1	5	
4	1.3.14.3	24	53
	9.1.5.2	4	
	9.1.2.2	6	
	9.10.2.6	19	
5 B	6.2.1.4	17	42
	9.1.1.5	14	
	9.9.5.3	11	
6	8.8.1.1	18	40
	9.1.1.3	10	
	9.4.1.3	12	
7	8.8.1.4	18	32
	9.12.1.6	5	
	9.8.1.1	7	
	9.1.5.1	2	
8 C	7.5.6.1	16	53
	9.1.3.6	10	
	9.2.4.4	9	
	9.10.8.3	15	
	9.8.3.1	3	
9	1.3.11.1	20	44
	9.10.4.6	16	
	9.1.4.4	8	
10 E	2.3.5.4	37	37
<b>Total K = 450</b>		<b>(max K = 450)</b>	

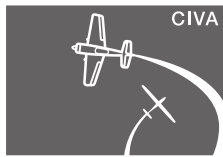

CIVA

FAI

AEROBATICS  
COMMISSION

CF1 2020

Form C

Pilot ID

CIVA Unlimited Programme1

Flight #

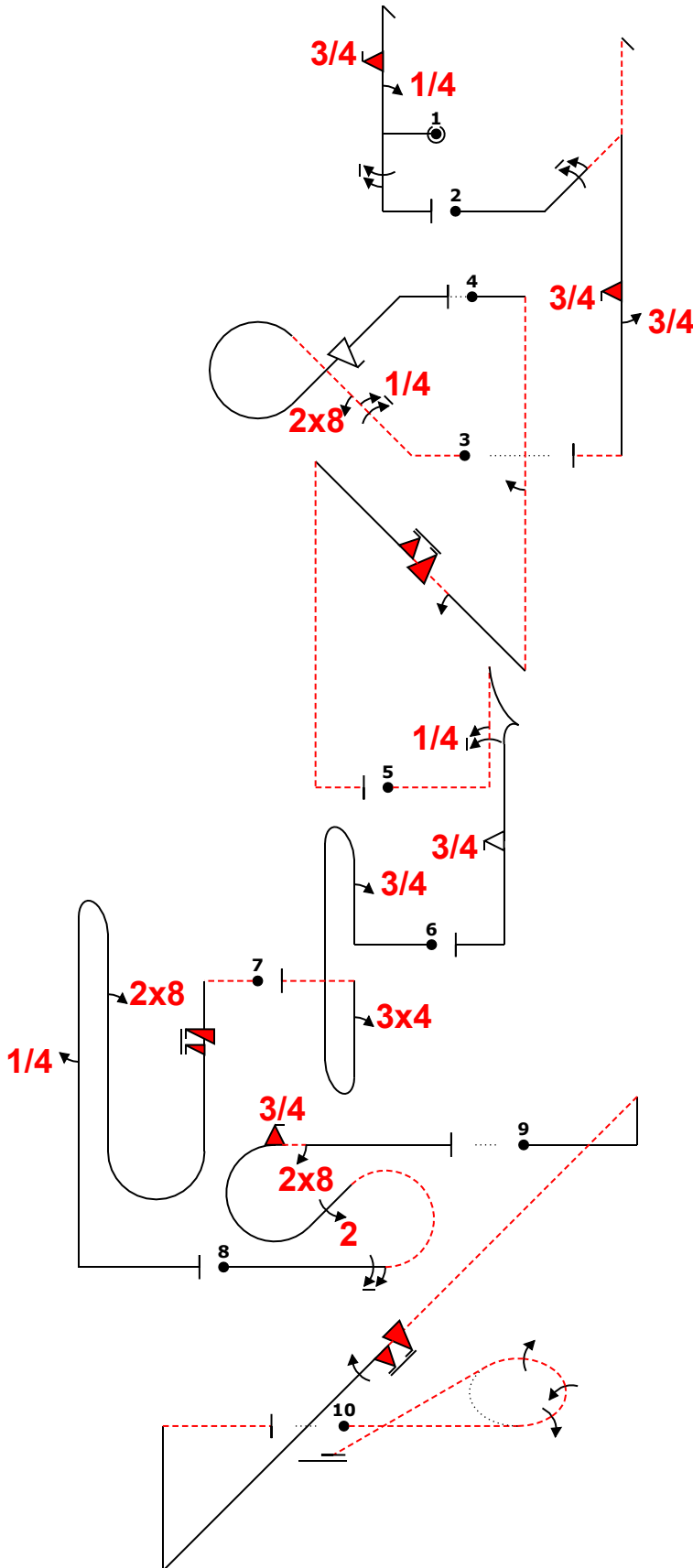
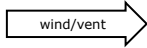

Power			
Fig	Aresti	K	
1 D	5.2.1.1	17	50
	9.1.1.1	6	
	9.10.1.3	17	
	9.1.5.6	10	
2	5.3.2.3	25	56
	9.1.2.6	12	
	9.10.5.3	13	
	9.1.5.3	6	
3 A	7.3.1.2	14	43
	9.1.2.5	11	
	9.8.2.1	5	
	9.9.2.4	13	
4	1.3.14.3	24	53
	9.1.5.2	4	
	9.1.2.2	6	
	9.10.2.6	19	
5 B	6.2.1.4	17	42
	9.1.1.5	14	
	9.9.5.3	11	
6	8.8.1.1	18	40
	9.1.1.3	10	
	9.4.1.3	12	
7	8.8.1.4	18	32
	9.12.1.6	5	
	9.8.1.1	7	
	9.1.5.1	2	
8 C	7.5.6.1	16	53
	9.1.3.6	10	
	9.2.4.4	9	
	9.10.8.3	15	
	9.8.3.1	3	
9	1.3.11.1	20	44
	9.10.4.6	16	
	9.1.4.4	8	
10 E	2.3.5.4	37	37
<b>Total K = 450</b>		<b>(max K = 450)</b>	

ORLOWSKI Pilot  
EA 300 SC FTGCJ  
A/C



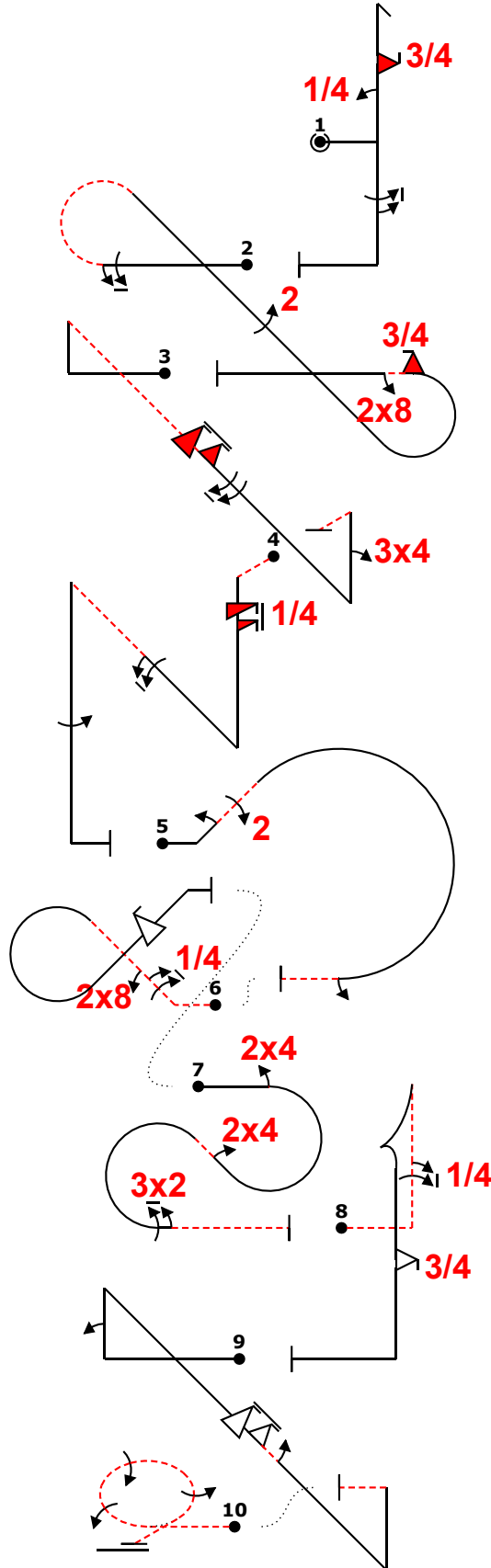
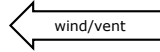

Power			
Fig	Aresti	K	
1 D	5.2.1.1	17	50
	9.1.1.1	6	
	9.10.1.3	17	
	9.1.5.6	10	
2 C	7.5.6.1	16	53
	9.1.3.6	10	
	9.2.4.4	9	
	9.10.8.3	15	
	9.8.3.1	3	
3	1.3.11.1	20	60
	9.10.4.6	16	
	9.1.4.8	12	
	9.4.1.3	12	
4	1.3.11.4	20	46
	9.12.1.5	6	
	9.1.2.6	12	
	9.1.5.4	8	
5	8.5.4.1	11	32
	9.1.2.2	6	
	9.2.2.4	11	
	9.1.3.2	4	
6 A	7.3.1.2	14	43
	9.1.2.5	11	
	9.8.2.1	5	
	9.9.2.4	13	
7	7.5.8.3	15	39
	9.4.3.2	5	
	9.4.2.2	7	
	9.2.3.6	12	
8 B	6.2.1.4	17	42
	9.1.1.5	14	
	9.9.5.3	11	
9	1.3.14.1	22	48
	9.1.1.2	8	
	9.9.4.6	14	
	9.1.4.2	4	
10 E	2.3.5.4	37	37
<b>Total K = 450</b> (max K = 450)			

**J-B Claudin** Pilot  
**EA 330 SC F-HDBV** A/C

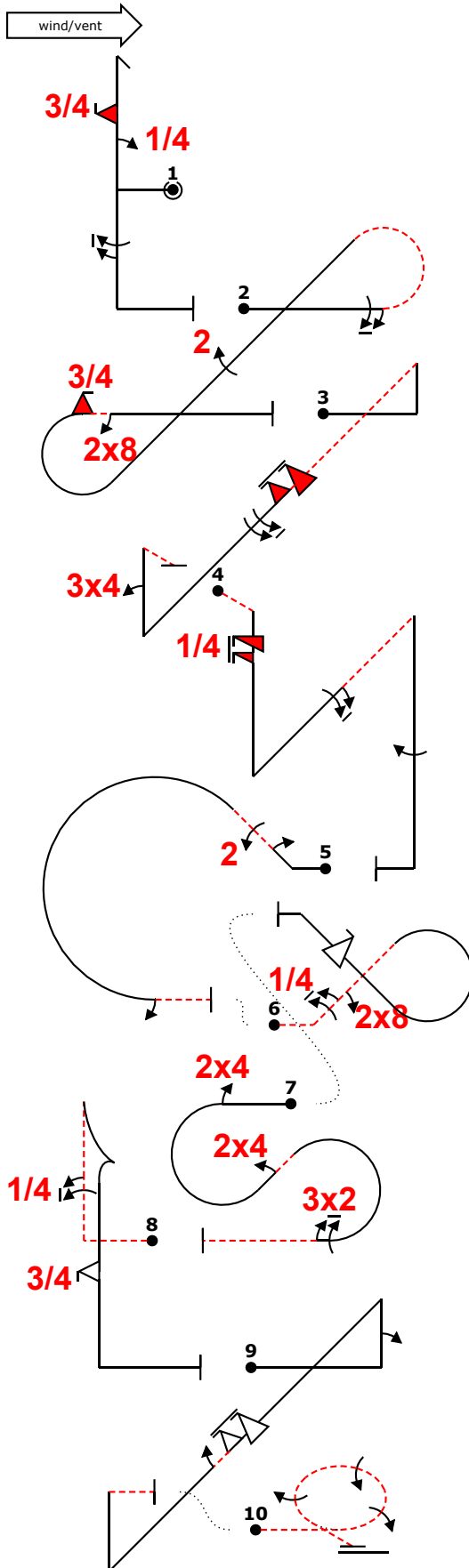

Power			
Fig	Aresti	K	
1 D	5.2.1.1	17	50
	9.1.1.1	6	
	9.10.1.3	17	
	9.1.5.6	10	
2 C	7.5.6.1	16	53
	9.1.3.6	10	
	9.2.4.4	9	
	9.10.8.3	15	
	9.8.3.1	3	
3	1.3.11.1	20	60
	9.10.4.6	16	
	9.1.4.8	12	
	9.4.1.3	12	
4	1.3.11.4	20	46
	9.12.1.5	6	
	9.1.2.6	12	
	9.1.5.4	8	
5	8.5.4.1	11	32
	9.1.2.2	6	
	9.2.2.4	11	
	9.1.3.2	4	
6 A	7.3.1.2	14	43
	9.1.2.5	11	
	9.8.2.1	5	
	9.9.2.4	13	
7	7.5.8.3	15	39
	9.4.3.2	5	
	9.4.2.2	7	
	9.2.3.6	12	
8 B	6.2.1.4	17	42
	9.1.1.5	14	
	9.9.5.3	11	
9	1.3.14.1	22	48
	9.1.1.2	8	
	9.9.4.6	14	
	9.1.4.2	4	
10 E	2.3.5.4	37	37
<b>Total K = 450</b> (max K = 450)			

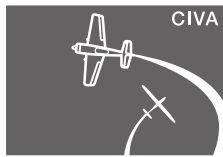

CIVA

FAI

AEROBATICS  
COMMISSION

Pilot ID

CIVA Unlimited Programme1

Form B

Flight #

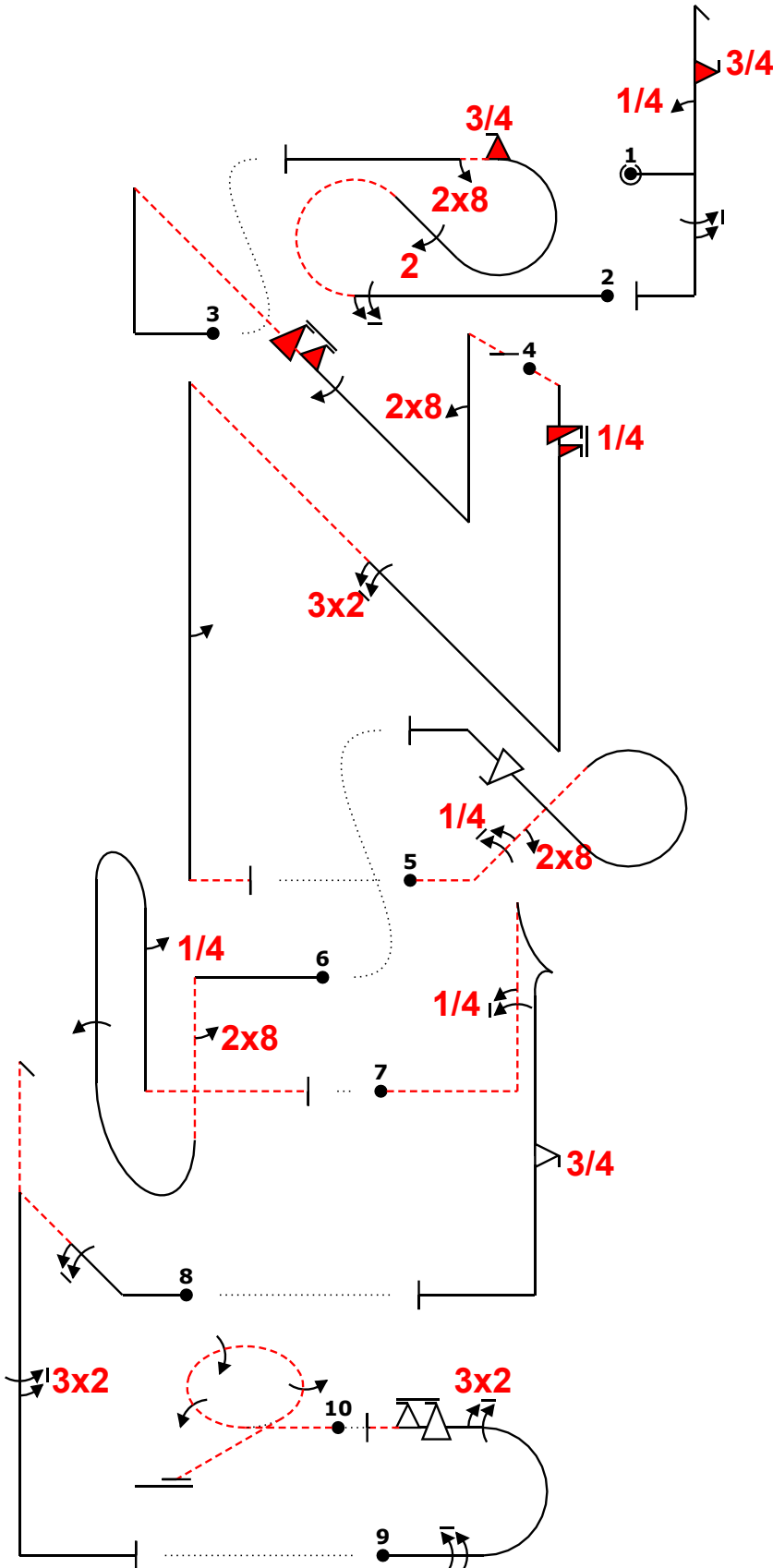
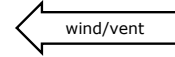

Power			
Fig	Aresti	K	
1 D	5.2.1.1	17	50
	9.1.1.1	6	
	9.10.1.3	17	
	9.1.5.6	10	
2 C	7.5.6.1	16	53
	9.1.3.6	10	
	9.2.4.4	9	
	9.10.8.3	15	
	9.8.3.1	3	
3	1.3.11.1	20	51
	9.10.4.6	16	
	9.1.4.4	8	
	9.8.1.1	7	
4	1.3.12.4	21	45
	9.12.1.5	6	
	9.2.2.6	14	
	9.1.5.2	4	
5 A	7.3.1.2	14	43
	9.1.2.5	11	
	9.8.2.1	5	
	9.9.2.4	13	
6	8.8.7.3	20	37
	9.8.5.1	3	
	9.1.1.4	12	
	9.1.5.1	2	
7 B	6.2.1.4	17	42
	9.1.1.5	14	
	9.9.5.3	11	
8	5.3.2.1	24	48
	9.1.2.6	12	
	9.2.5.6	12	
9	7.2.1.1	6	44
	9.1.3.8	12	
	9.2.3.6	12	
	9.9.3.6	14	
10 E	2.3.5.4	37	37
<b>Total K = 450</b>		<b>(max K = 450)</b>	

Check: 17-9-2020 0:52 OpenAero 2020.1.9 2020 civa unlimited programme1 Sequence is correct

Alex HORY Pilot  
Extra 330 F-HIGS  
A/C

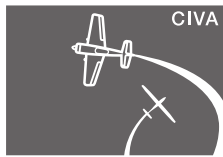

FAI

AEROBATICS  
COMMISSION

Form C

Pilot ID

CIVA Unlimited Programme1

Flight #

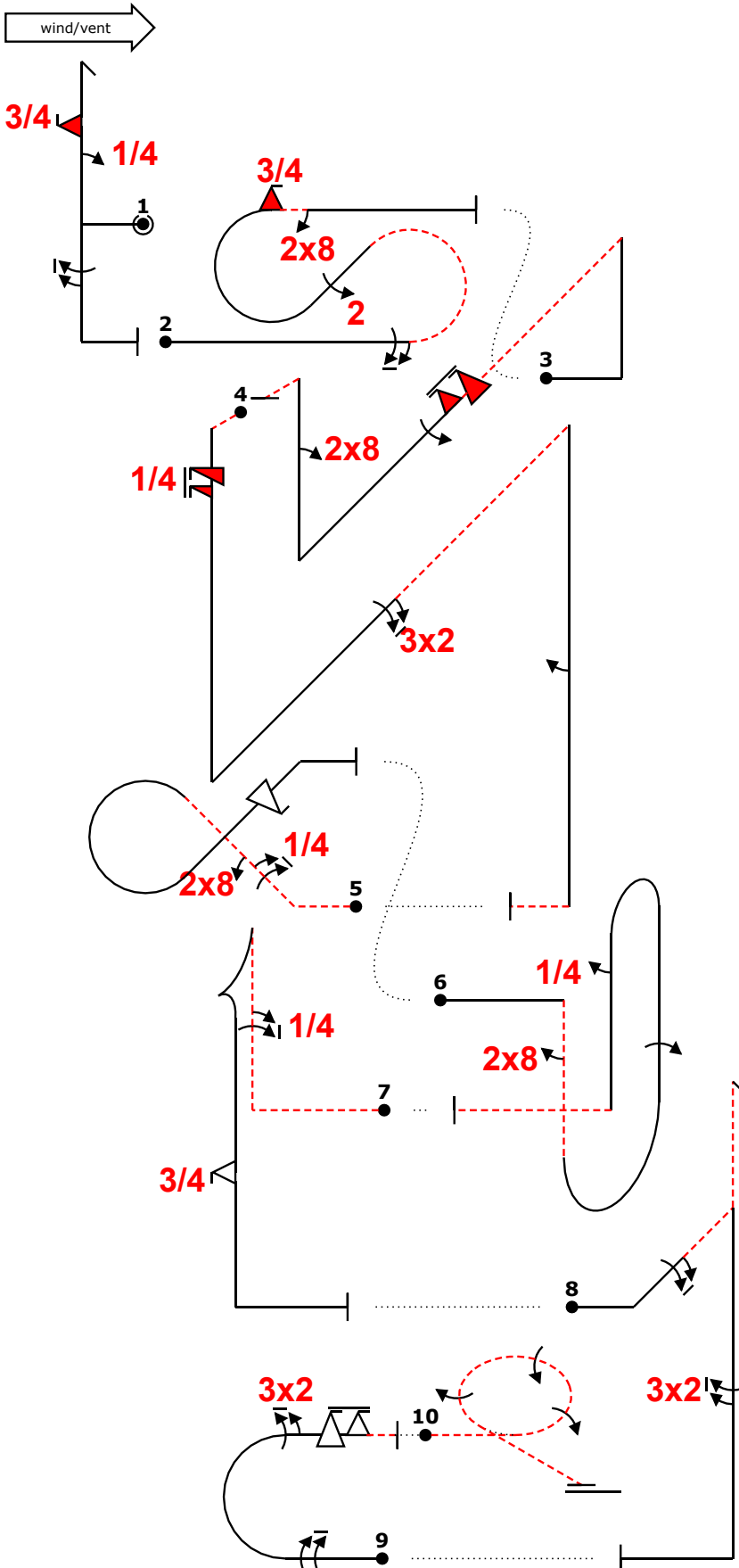

Power			
Fig	Aresti	K	
1 D	5.2.1.1	17	50
	9.1.1.1	6	
	9.10.1.3	17	
	9.1.5.6	10	
2 C	7.5.6.1	16	53
	9.1.3.6	10	
	9.2.4.4	9	
	9.10.8.3	15	
	9.8.3.1	3	
3	1.3.11.1	20	51
	9.10.4.6	16	
	9.1.4.4	8	
	9.8.1.1	7	
4	1.3.12.4	21	45
	9.12.1.5	6	
	9.2.2.6	14	
	9.1.5.2	4	
5 A	7.3.1.2	14	43
	9.1.2.5	11	
	9.8.2.1	5	
	9.9.2.4	13	
6	8.8.7.3	20	37
	9.8.5.1	3	
	9.1.1.4	12	
	9.1.5.1	2	
7 B	6.2.1.4	17	42
	9.1.1.5	14	
	9.9.5.3	11	
8	5.3.2.1	24	48
	9.1.2.6	12	
	9.2.5.6	12	
9	7.2.1.1	6	44
	9.1.3.8	12	
	9.2.3.6	12	
	9.9.3.6	14	
10 E	2.3.5.4	37	37
<b>Total K = 450</b>			
(max K = 450)			

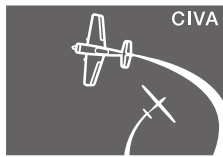

CIVA

FAI

AEROBATICS  
COMMISSION

CF1 Septembre 2020

Form B

Pilot ID

CIVA Unlimited Programme1

Flight #

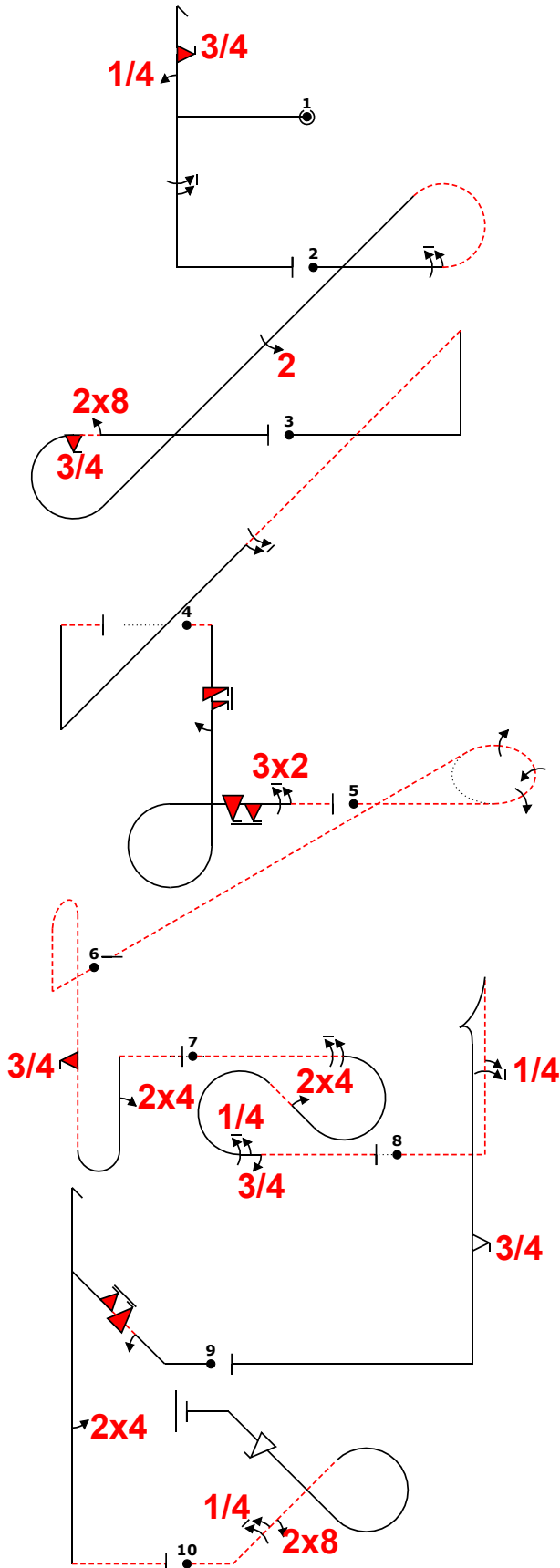
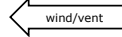

Power			
Fig	Aresti	K	
1 D	5.2.1.1	17	50
	9.1.1.1	6	
	9.10.1.3	17	
	9.1.5.6	10	
2 C	7.5.6.1	16	53
	9.1.3.6	10	
	9.2.4.4	9	
	9.10.8.3	15	
	9.8.3.1	3	
3	1.3.11.1	20	30
	9.1.4.6	10	
4	8.6.1.4	12	52
	9.12.1.6	5	
	9.1.5.2	4	
	9.10.8.6	19	
5 E	2.3.5.4	37	37
6	8.8.4.2	22	44
	9.10.5.3	13	
	9.4.1.2	9	
7	7.5.7.4	15	49
	9.1.3.8	12	
	9.4.2.2	7	
	9.1.3.5	9	
8 B	6.2.1.4	17	42
	9.1.1.5	14	
	9.9.5.3	11	
9	5.3.1.3	20	50
	9.1.2.2	6	
	9.10.2.6	19	
	9.4.5.2	5	
10 A	7.3.1.2	14	43
	9.1.2.5	11	
	9.8.2.1	5	
	9.9.2.4	13	
<b>Total K = 450</b> (max K = 450)			

Check: 17-9-2020 0:56 OpenAero 2020.1.9 2020 civa unlimited programme1 Sequence is correct

Vignes Pilot  
EA330SC F-HXAL  
A/C

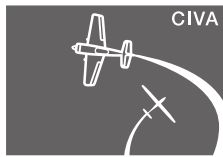

FAI

AEROBATICS  
COMMISSION

CF1 Septembre 2020

Form C

Pilot ID

CIVA Unlimited Programme1

Flight #

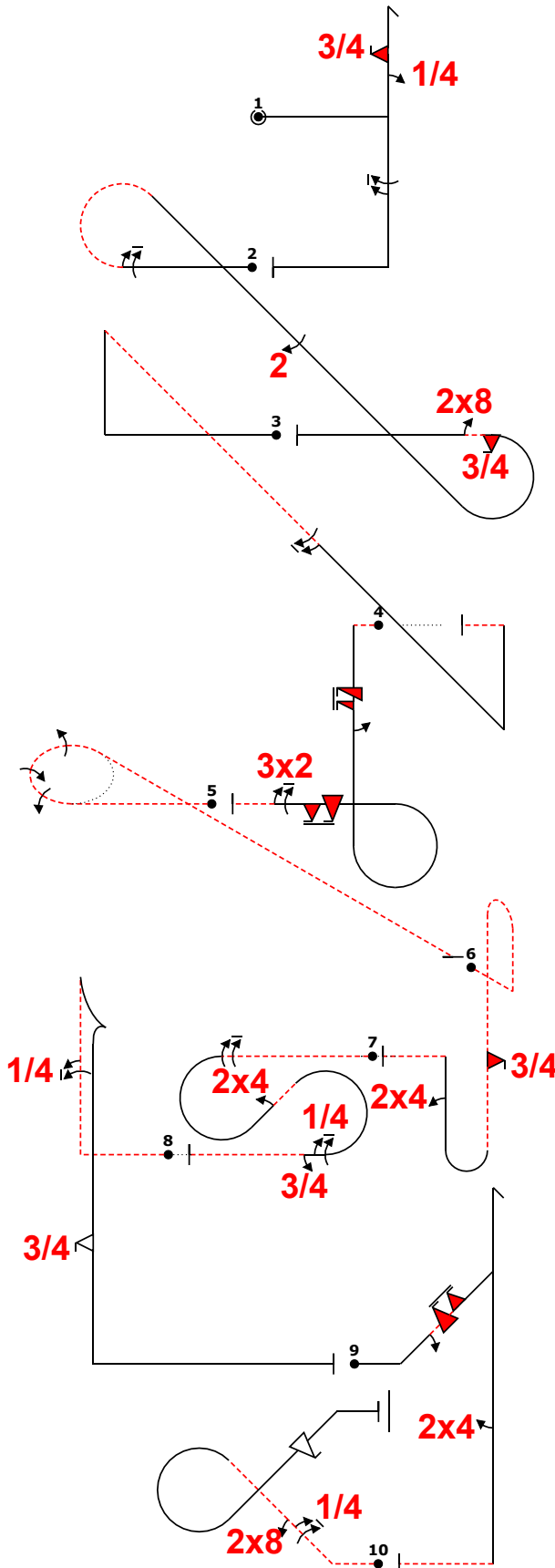
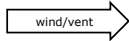

Power			
Fig	Aresti	K	
1 D	5.2.1.1	17	50
	9.1.1.1	6	
	9.10.1.3	17	
	9.1.5.6	10	
2 C	7.5.6.1	16	53
	9.1.3.6	10	
	9.2.4.4	9	
	9.10.8.3	15	
	9.8.3.1	3	
3	1.3.11.1	20	30
	9.1.4.6	10	
4	8.6.1.4	12	52
	9.12.1.6	5	
	9.1.5.2	4	
	9.10.8.6	19	
	9.2.3.6	12	
5 E	2.3.5.4	37	37
6	8.8.4.2	22	44
	9.10.5.3	13	
	9.4.1.2	9	
7	7.5.7.4	15	49
	9.1.3.8	12	
	9.4.2.2	7	
	9.1.3.5	9	
	9.1.3.3	6	
8 B	6.2.1.4	17	42
	9.1.1.5	14	
	9.9.5.3	11	
9	5.3.1.3	20	50
	9.1.2.2	6	
	9.10.2.6	19	
	9.4.5.2	5	
10 A	7.3.1.2	14	43
	9.1.2.5	11	
	9.8.2.1	5	
	9.9.2.4	13	
<b>Total K = 450</b>		<b>(max K = 450)</b>	

Vignes Pilot  
EA330SC F-HXAL  
A/C

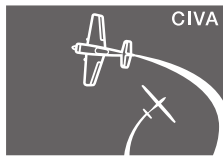

CIVA

FAI

AEROBATICS  
COMMISSION

Pilot ID

CIVA Unlimited Free Known

Form B

Flight #

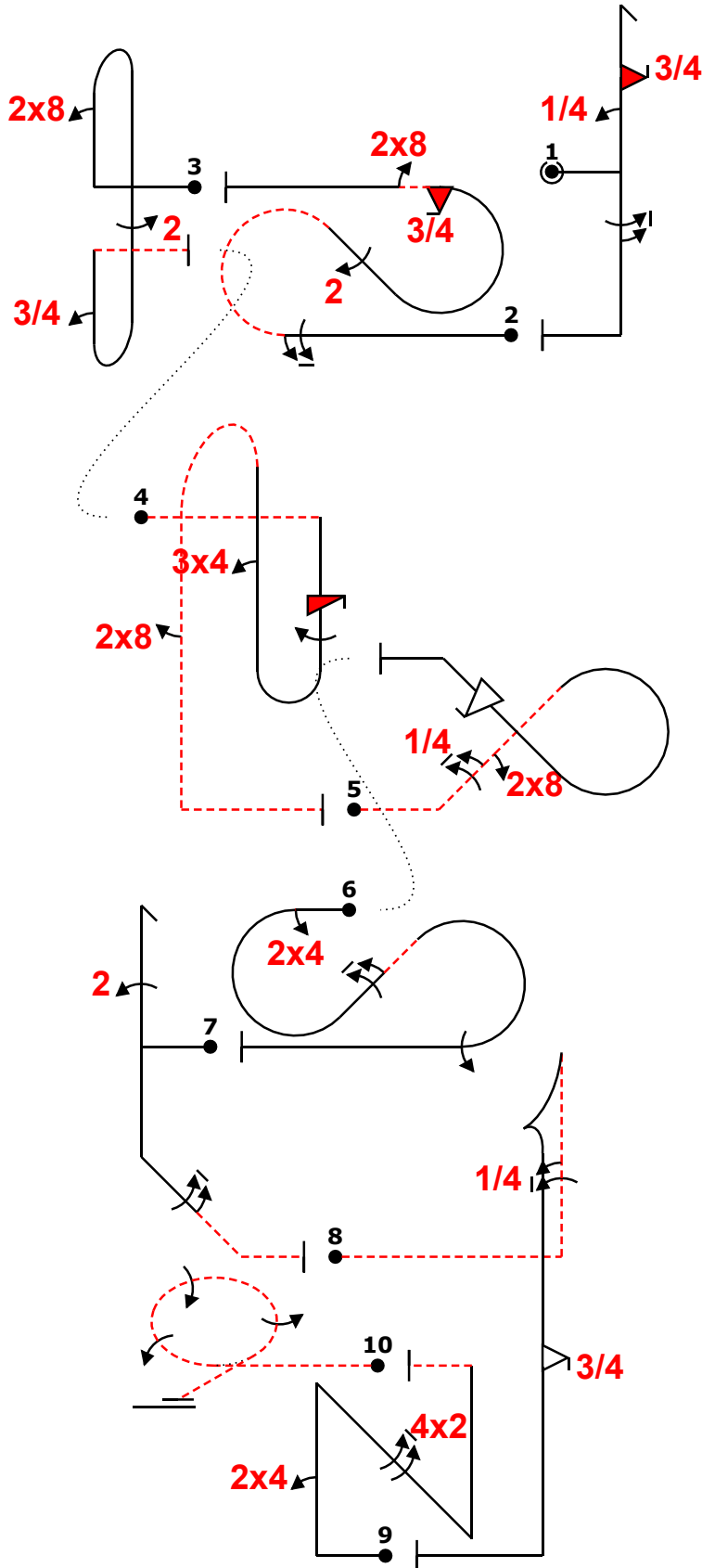
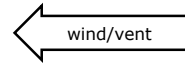

Power			
Fig	Aresti	K	
1 D	5.2.1.1	17	50
	9.1.1.1	6	
	9.10.1.3	17	
	9.1.5.6	10	
2 C	7.5.6.1	16	53
	9.1.3.6	10	
	9.2.4.4	9	
	9.10.8.3	15	
	9.8.3.1	3	
3	8.8.1.1	18	44
	9.8.1.1	7	
	9.2.5.4	9	
	9.1.1.3	10	
4	8.8.4.4	22	52
	9.12.1.4	7	
	9.1.5.4	8	
	9.4.1.3	12	
	9.8.5.1	3	
5 A	7.3.1.2	14	43
	9.1.2.5	11	
	9.8.2.1	5	
	9.9.2.4	13	
6	7.5.5.3	15	40
	9.4.3.2	5	
	9.1.2.6	12	
	9.1.3.4	8	
7	5.3.4.3	20	43
	9.2.1.4	13	
	9.1.4.6	10	
8 B	6.2.1.4	17	42
	9.1.1.5	14	
	9.9.5.3	11	
9	1.3.14.1	22	46
	9.4.1.2	9	
	9.2.4.8	15	
10 E	2.3.5.4	37	37
<b>Total K = 450</b> (max K = 450)			

LALLOUE Pilot  
EXTRA330SC FTGCJ  
A/C

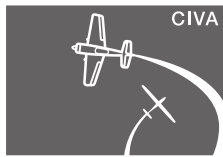

FAI

AEROBATICS  
COMMISSION

Pilot ID

CIVA Unlimited Free Known

Form C

Flight #

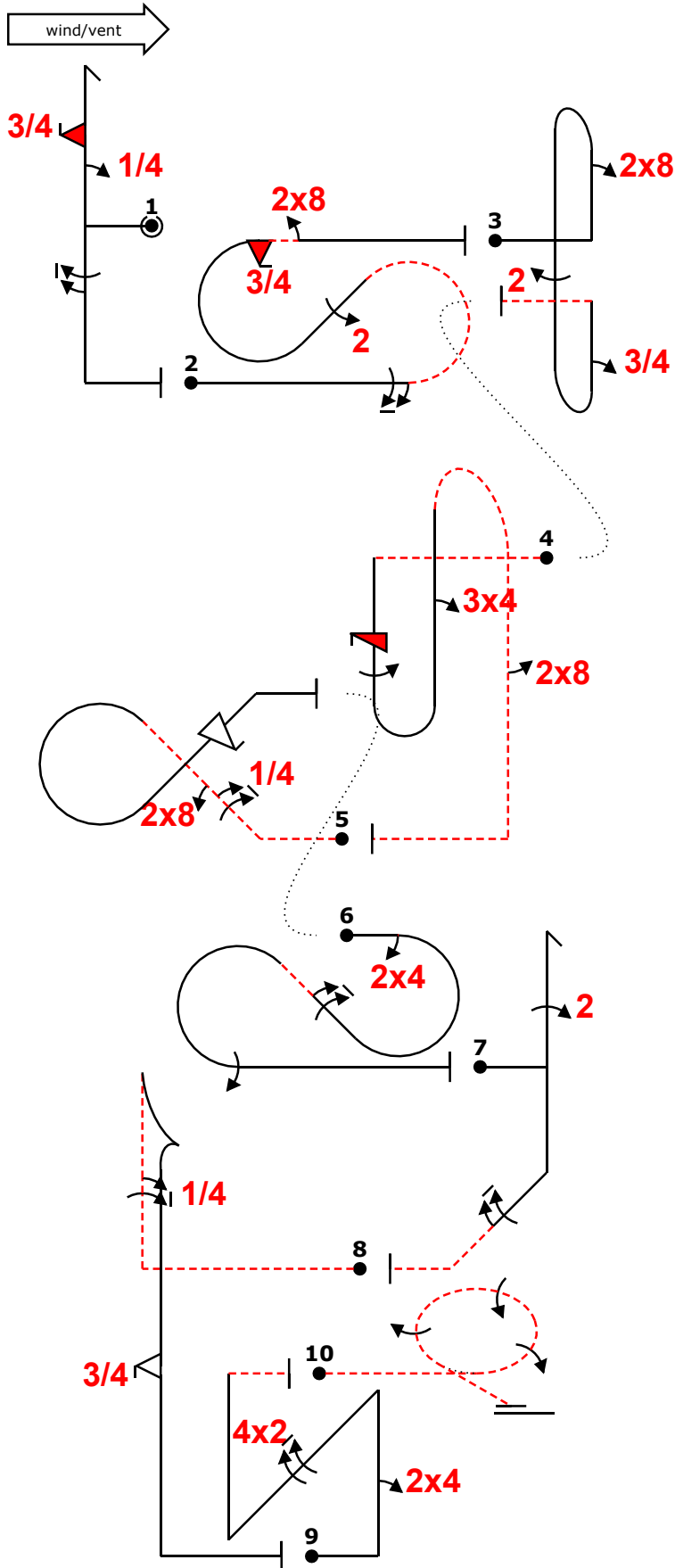

Power			
Fig	Aresti	K	
1 D	5.2.1.1	17	50
	9.1.1.1	6	
	9.10.1.3	17	
	9.1.5.6	10	
2 C	7.5.6.1	16	53
	9.1.3.6	10	
	9.2.4.4	9	
	9.10.8.3	15	
	9.8.3.1	3	
3	8.8.1.1	18	44
	9.8.1.1	7	
	9.2.5.4	9	
	9.1.1.3	10	
4	8.8.4.4	22	52
	9.12.1.4	7	
	9.1.5.4	8	
	9.4.1.3	12	
	9.8.5.1	3	
5 A	7.3.1.2	14	43
	9.1.2.5	11	
	9.8.2.1	5	
	9.9.2.4	13	
6	7.5.5.3	15	40
	9.4.3.2	5	
	9.1.2.6	12	
	9.1.3.4	8	
7	5.3.4.3	20	43
	9.2.1.4	13	
	9.1.4.6	10	
8 B	6.2.1.4	17	42
	9.1.1.5	14	
	9.9.5.3	11	
9	1.3.14.1	22	46
	9.4.1.2	9	
	9.2.4.8	15	
10 E	2.3.5.4	37	37
<b>Total K = 450</b> (max K = 450)			

LALLOUE Pilot  
EXTRA330SC FTGCJ  
A/C



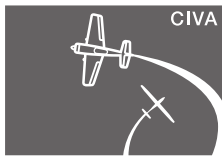

CIVA

FAI

AEROBATICS  
COMMISSION

Pilot ID

CIVA Unlimited Free Known

Form B

Flight #

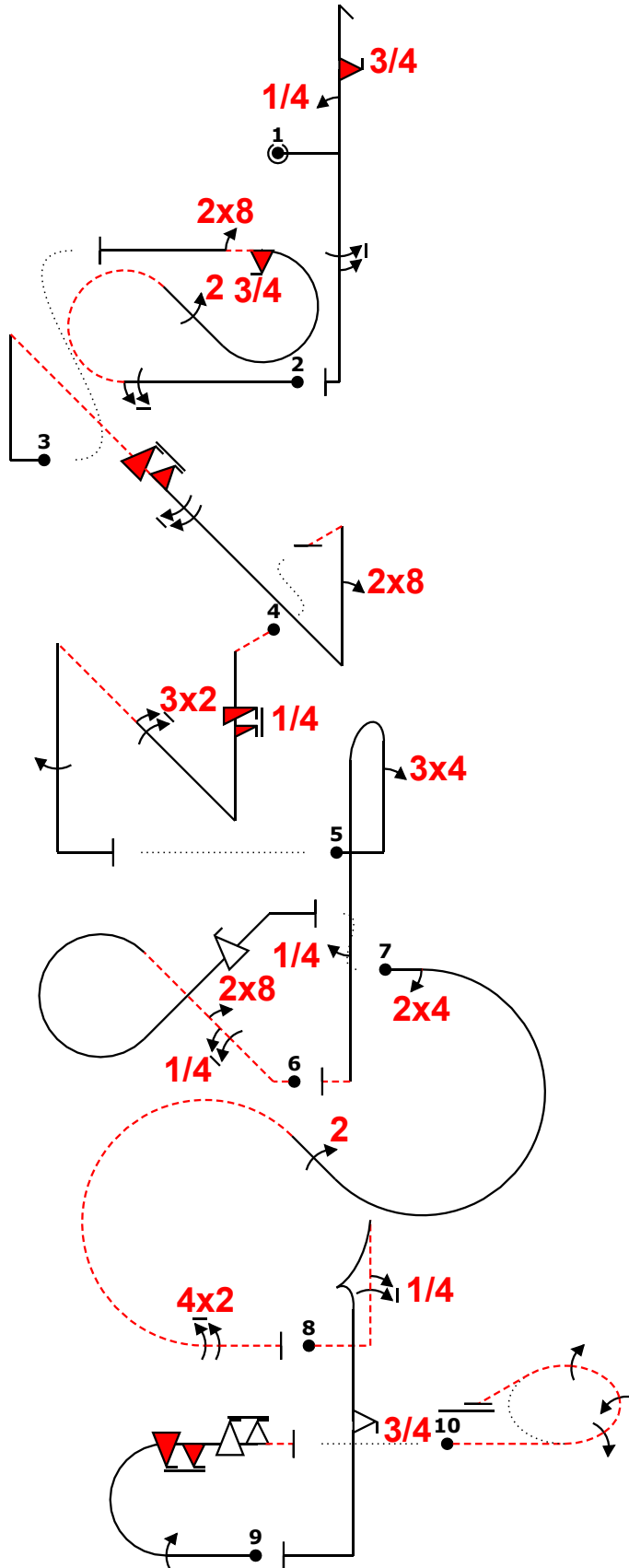
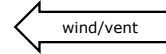

Power			
Fig	Aresti	K	
1 D	5.2.1.1	17	50
	9.1.1.1	6	
	9.10.1.3	17	
	9.1.5.6	10	
2 C	7.5.6.1	16	53
	9.1.3.6	10	
	9.2.4.4	9	
	9.10.8.3	15	
	9.8.3.1	3	
3	1.3.11.1	20	55
	9.10.4.6	16	
	9.1.4.8	12	
	9.8.1.1	7	
4	1.3.11.4	20	48
	9.12.1.5	6	
	9.2.2.6	14	
	9.1.5.4	8	
5	8.4.2.1	14	28
	9.4.1.3	12	
	9.1.5.1	2	
6 A	7.3.1.2	14	43
	9.1.2.5	11	
	9.8.2.1	5	
	9.9.2.4	13	
7	7.5.3.3	16	47
	9.4.3.2	5	
	9.2.2.4	11	
	9.2.3.8	15	
8 B	6.2.1.4	17	42
	9.1.1.5	14	
	9.9.5.3	11	
9	7.2.1.1	6	47
	9.1.3.4	8	
	9.10.8.6	19	
	9.9.3.6	14	
10 E	2.3.5.4	37	37
<b>Total K = 450</b> (max K = 450)			

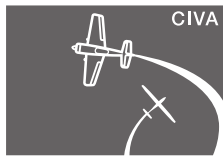

FAI

AEROBATICS  
COMMISSION

Pilot ID

CIVA Unlimited Free Known

Form C

Flight #

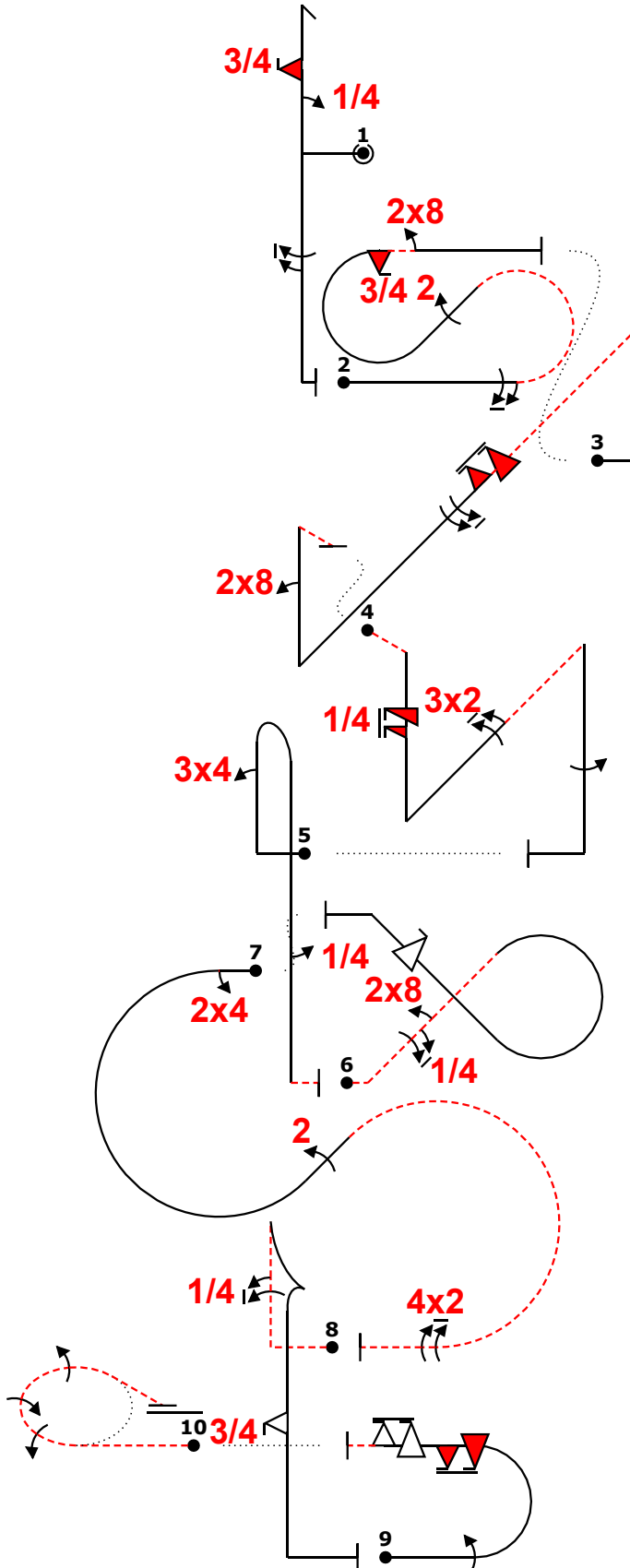
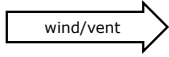

Power			
Fig	Aresti	K	
1 D	5.2.1.1	17	50
	9.1.1.1	6	
	9.1.0.1.3	17	
	9.1.5.6	10	
2 C	7.5.6.1	16	53
	9.1.3.6	10	
	9.2.4.4	9	
	9.1.0.8.3	15	
	9.8.3.1	3	
3	1.3.11.1	20	55
	9.1.0.4.6	16	
	9.1.4.8	12	
	9.8.1.1	7	
4	1.3.11.4	20	48
	9.1.2.1.5	6	
	9.2.2.6	14	
	9.1.5.4	8	
5	8.4.2.1	14	28
	9.4.1.3	12	
	9.1.5.1	2	
6 A	7.3.1.2	14	43
	9.1.2.5	11	
	9.8.2.1	5	
	9.9.2.4	13	
7	7.5.3.3	16	47
	9.4.3.2	5	
	9.2.2.4	11	
	9.2.3.8	15	
8 B	6.2.1.4	17	42
	9.1.1.5	14	
	9.9.5.3	11	
9	7.2.1.1	6	47
	9.1.3.4	8	
	9.1.0.8.6	19	
	9.9.3.6	14	
10 E	2.3.5.4	37	37
<b>Total K = 450</b> (max K = 450)			

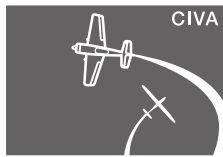

FAI

AEROBATICS  
COMMISSION

Form B

Pilot ID

CIVA Unlimited Programme1

Flight #

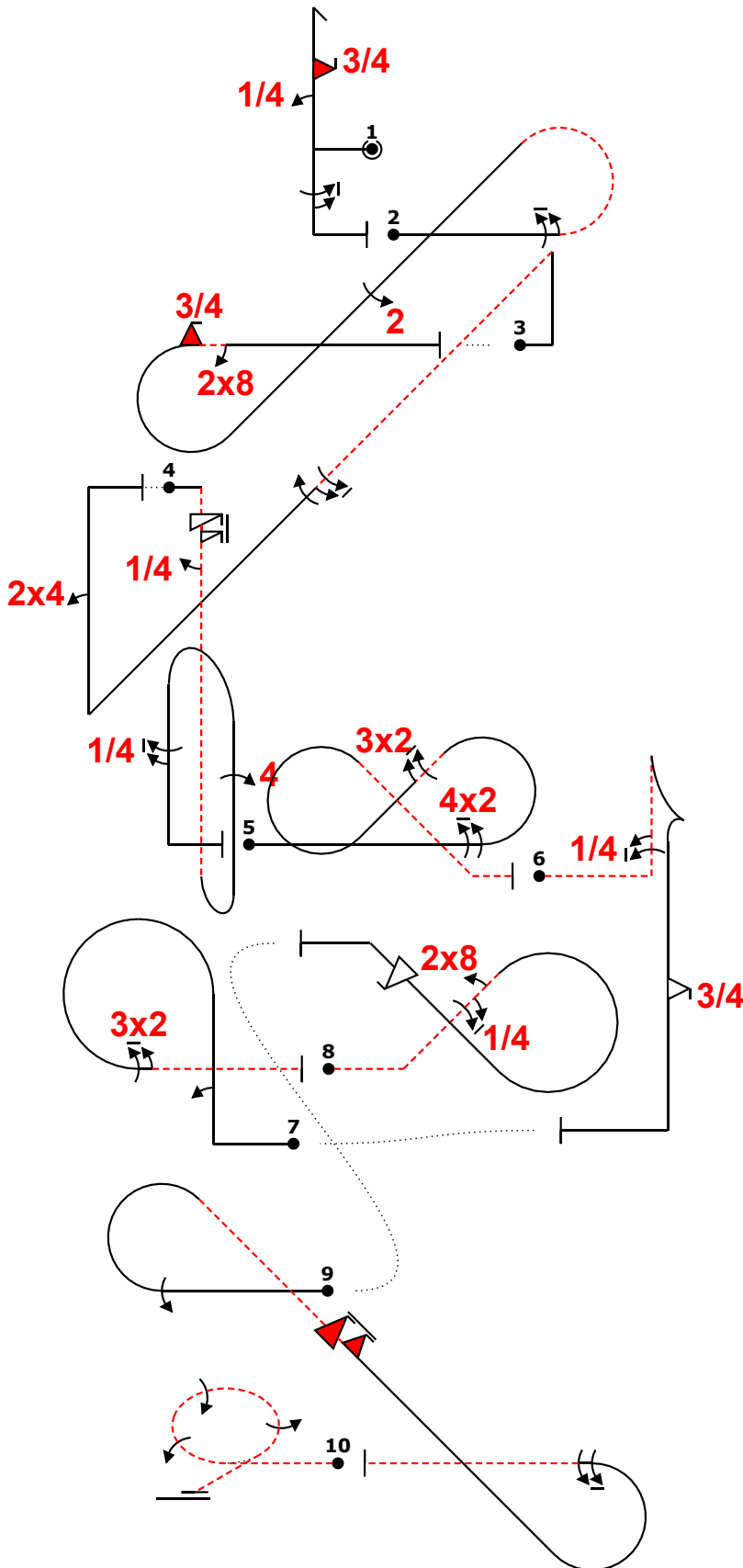
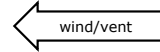

Power			
Fig	Aresti	K	
1 D	5.2.1.1	17	50
	9.1.1.1	6	
	9.10.1.3	17	
	9.1.5.6	10	
2 C	7.5.6.1	16	53
	9.1.3.6	10	
	9.2.4.4	9	
	9.10.8.3	15	
	9.8.3.1	3	
3	1.3.12.1	21	48
	9.1.4.6	10	
	9.1.4.4	8	
	9.4.1.2	9	
4	8.8.8.3	19	48
	9.11.1.6	3	
	9.1.5.1	2	
	9.4.1.4	15	
	9.1.5.5	9	
5	7.8.3.1	19	46
	9.2.3.8	15	
	9.2.4.6	12	
6 B	6.2.1.4	17	42
	9.1.1.5	14	
	9.9.5.3	11	
7	8.6.2.1	12	32
	9.1.1.2	8	
	9.2.3.6	12	
8 A	7.3.1.2	14	43
	9.1.2.5	11	
	9.8.2.1	5	
	9.9.2.4	13	
9	7.5.2.1	15	51
	9.1.3.4	8	
	9.10.4.6	16	
	9.1.3.8	12	
10 E	2.3.5.4	37	37
<b>Total K = 450</b> (max K = 450)			



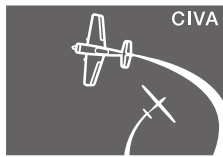

CIVA

FAI

AEROBATICS  
COMMISSION

Pilot ID

CIVA Unlimited Programme1

Form B

Flight #

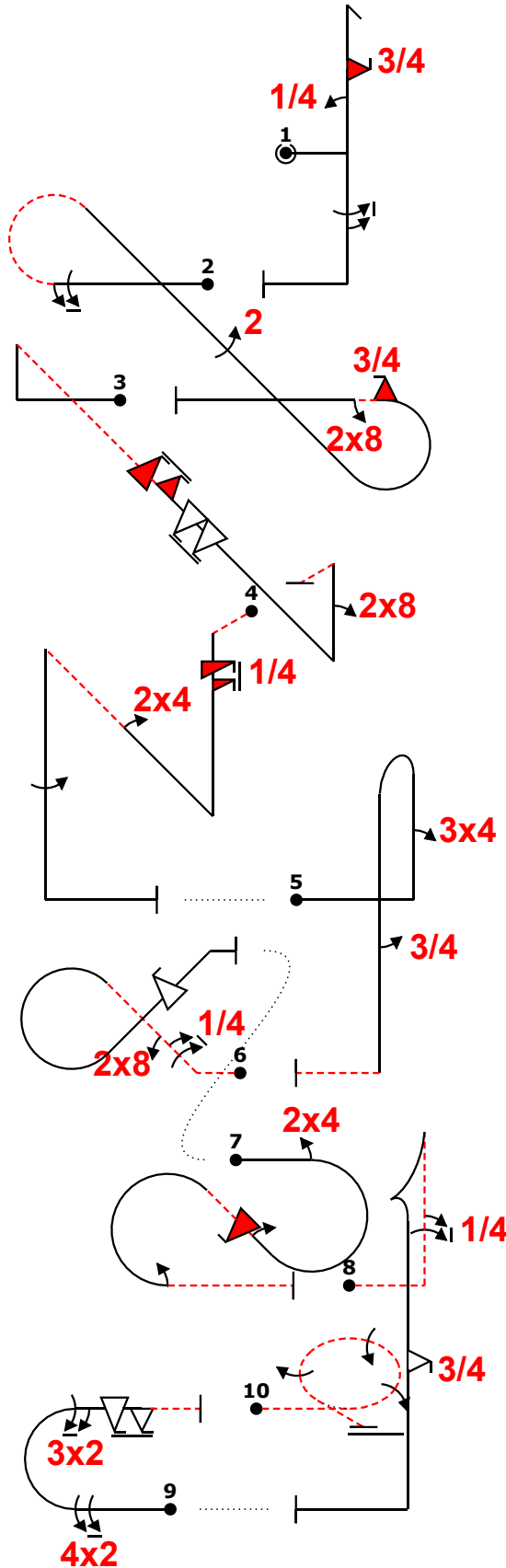
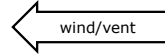

Power			
Fig	Aresti	K	
1 D	5.2.1.1	17	50
	9.1.1.1	6	
	9.10.1.3	17	
	9.1.5.6	10	
2 C	7.5.6.1	16	53
	9.1.3.6	10	
	9.2.4.4	9	
	9.10.8.3	15	
	9.8.3.1	3	
3	1.3.11.1	20	60
	9.10.4.6	16	
	9.9.4.8	17	
	9.8.1.1	7	
4	1.3.11.4	20	41
	9.12.1.5	6	
	9.4.2.2	7	
	9.1.5.4	8	
5	8.4.2.1	14	32
	9.4.1.3	12	
	9.1.5.3	6	
6 A	7.3.1.2	14	43
	9.1.2.5	11	
	9.8.2.1	5	
	9.9.2.4	13	
7	7.5.8.3	15	45
	9.4.3.2	5	
	9.1.2.2	6	
	9.10.2.4	15	
	9.1.3.2	4	
8 B	6.2.1.4	17	42
	9.1.1.5	14	
	9.9.5.3	11	
9	7.2.1.1	6	47
	9.2.3.8	15	
	9.2.3.6	12	
	9.9.3.6	14	
10 E	2.3.5.4	37	37
<b>Total K = 450</b> (max K = 450)			

Thomas LIBAUD Pilot  
E330SC FHMKF A/C

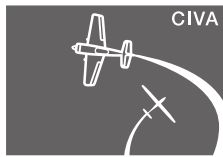

CIVA

FAI

AEROBATICS  
COMMISSION

Form C

Pilot ID

CIVA Unlimited Programme1

Flight #

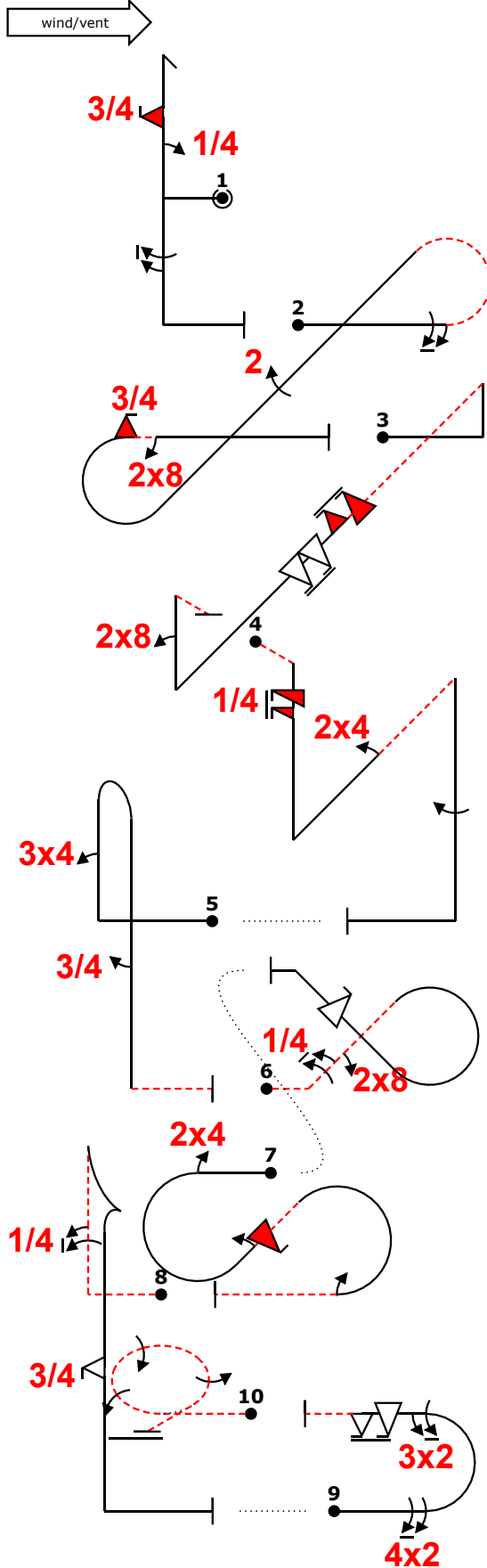

Power			
Fig	Aresti	K	
1 D	5.2.1.1	17	50
	9.1.1.1	6	
	9.10.1.3	17	
	9.1.5.6	10	
2 C	7.5.6.1	16	53
	9.1.3.6	10	
	9.2.4.4	9	
	9.10.8.3	15	
	9.8.3.1	3	
3	1.3.11.1	20	60
	9.10.4.6	16	
	9.9.4.8	17	
	9.8.1.1	7	
4	1.3.11.4	20	41
	9.12.1.5	6	
	9.4.2.2	7	
	9.1.5.4	8	
5	8.4.2.1	14	32
	9.4.1.3	12	
	9.1.5.3	6	
6 A	7.3.1.2	14	43
	9.1.2.5	11	
	9.8.2.1	5	
	9.9.2.4	13	
7	7.5.8.3	15	45
	9.4.3.2	5	
	9.1.2.2	6	
	9.10.2.4	15	
	9.1.3.2	4	
8 B	6.2.1.4	17	42
	9.1.1.5	14	
	9.9.5.3	11	
9	7.2.1.1	6	47
	9.2.3.8	15	
	9.2.3.6	12	
	9.9.3.6	14	
10 E	2.3.5.4	37	37
<b>Total K = 450</b> (max K = 450)			

Pilot ID

France Unlimited connu-libre

Flight #

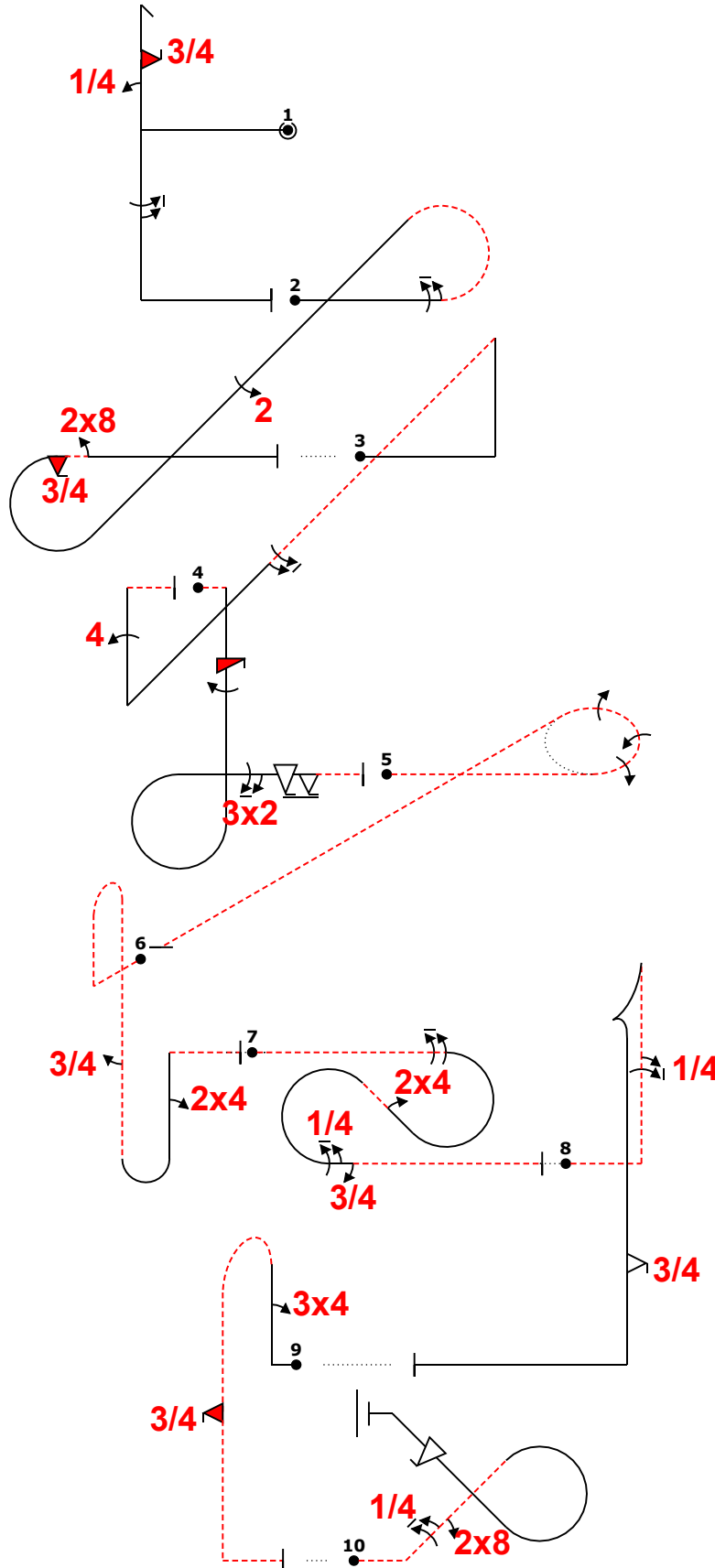
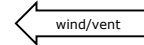

Power			
Fig	Aresti	K	
1 D	5.2.1.1	17	50
	9.1.1.1	6	
	9.10.1.3	17	
	9.1.5.6	10	
2 C	7.5.6.1	16	53
	9.1.3.6	10	
	9.2.4.4	9	
	9.10.8.3	15	
	9.8.3.1	3	
3	1.3.11.1	20	45
	9.1.4.6	10	
	9.4.1.4	15	
4	8.6.1.4	12	53
	9.12.1.4	7	
	9.1.5.4	8	
	9.2.3.6	12	
	9.9.3.6	14	
5 E	2.3.5.4	37	37
6	8.8.4.2	22	37
	9.1.5.3	6	
	9.4.1.2	9	
7	7.5.7.4	15	49
	9.1.3.8	12	
	9.4.2.2	7	
	9.1.3.5	9	
	9.1.3.3	6	
8 B	6.2.1.4	17	42
	9.1.1.5	14	
	9.9.5.3	11	
9	8.4.4.1	16	41
	9.4.1.3	12	
	9.10.5.3	13	
10 A	7.3.1.2	14	43
	9.1.2.5	11	
	9.8.2.1	5	
	9.9.2.4	13	
<b>Total K = 450</b>		<b>(max K = 450)</b>	

Pilot ID

France Unlimited connu-libre

Flight #

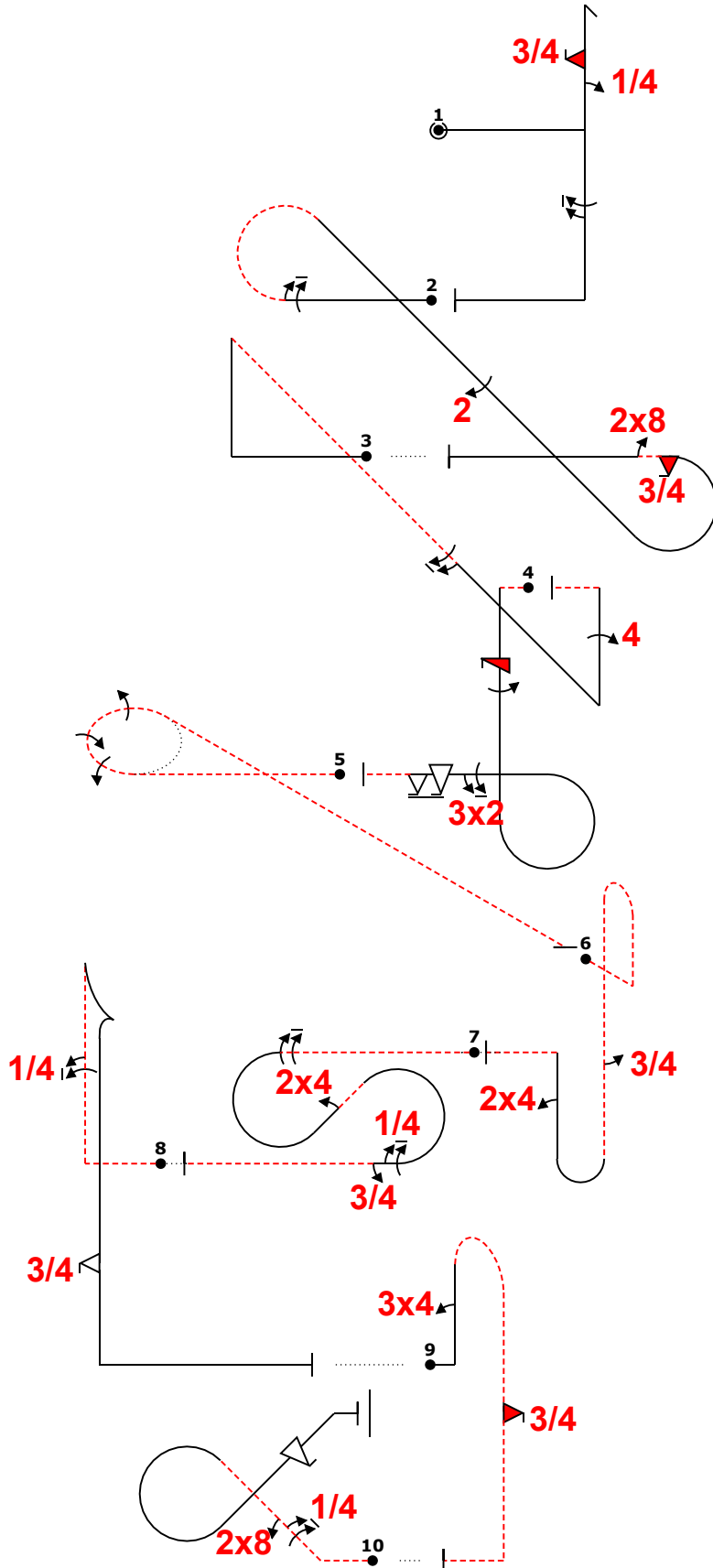
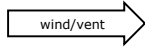

Power			
Fig	Aresti	K	
1	5.2.1.1	17	50
	9.1.1.1	6	
	9.10.1.3	17	
	9.1.5.6	10	
2	7.5.6.1	16	53
	9.1.3.6	10	
	9.2.4.4	9	
	9.10.8.3	15	
	9.8.3.1	3	
3	1.3.11.1	20	45
	9.1.4.6	10	
	9.4.1.4	15	
4	8.6.1.4	12	53
	9.12.1.4	7	
	9.1.5.4	8	
	9.2.3.6	12	
	9.9.3.6	14	
5	2.3.5.4	37	37
6	8.8.4.2	22	37
	9.1.5.3	6	
	9.4.1.2	9	
7	7.5.7.4	15	49
	9.1.3.8	12	
	9.4.2.2	7	
	9.1.3.5	9	
	9.1.3.3	6	
8	6.2.1.4	17	42
	9.1.1.5	14	
	9.9.5.3	11	
9	8.4.4.1	16	41
	9.4.1.3	12	
	9.10.5.3	13	
10	7.3.1.2	14	43
	9.1.2.5	11	
	9.8.2.1	5	
	9.9.2.4	13	
<b>Total K = 450</b>		<b>(max K = 450)</b>	