

FAI

AEROBATICS
COMMISSION

Pilot ID

CIVA Advanced Free Known

Form C

Flight #

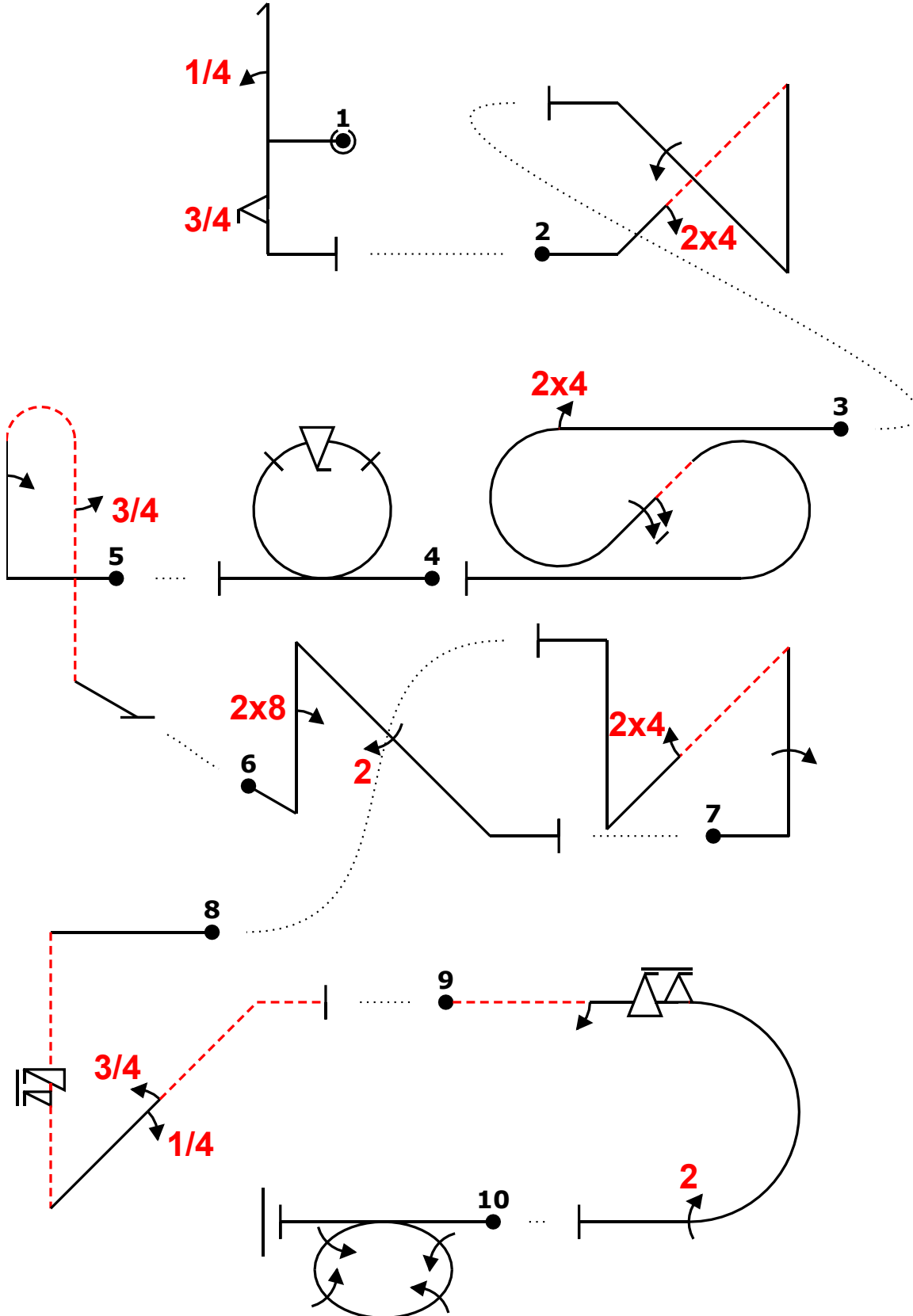
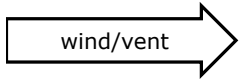

Power			
Fig	Aresti	K	
1 A	5.2.1.1	17	34
	9.1.1.1	6	
	9.9.5.3	11	
2 E	1.3.2.1	18	35
	9.4.2.2	7	
	9.1.2.4	10	
3 C	7.5.5.3	15	32
	9.4.3.2	5	
	9.1.2.6	12	
4	7.4.1.1	10	21
	9.9.3.4	11	
5 D	8.4.3.1	15	29
	9.1.1.2	8	
	9.1.5.3	6	
6	1.2.6.1	14	30
	9.8.1.1	7	
	9.2.4.4	9	
7	1.3.12.1	21	38
	9.1.1.4	12	
	9.4.4.2	5	
8 B	1.2.8.3	15	30
	9.11.1.6	3	
	9.1.2.1	4	
	9.1.2.3	8	
9	7.2.1.4	6	33
	9.1.3.2	4	
	9.9.3.6	14	
	9.2.3.4	9	
10	2.4.7.1	38	38
Total K = 320 (max K = 320)			

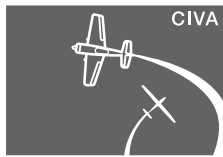

CIVA

FAI

AEROBATICS
COMMISSION

Pilot ID

CIVA Advanced Free Known

Form B

Flight #

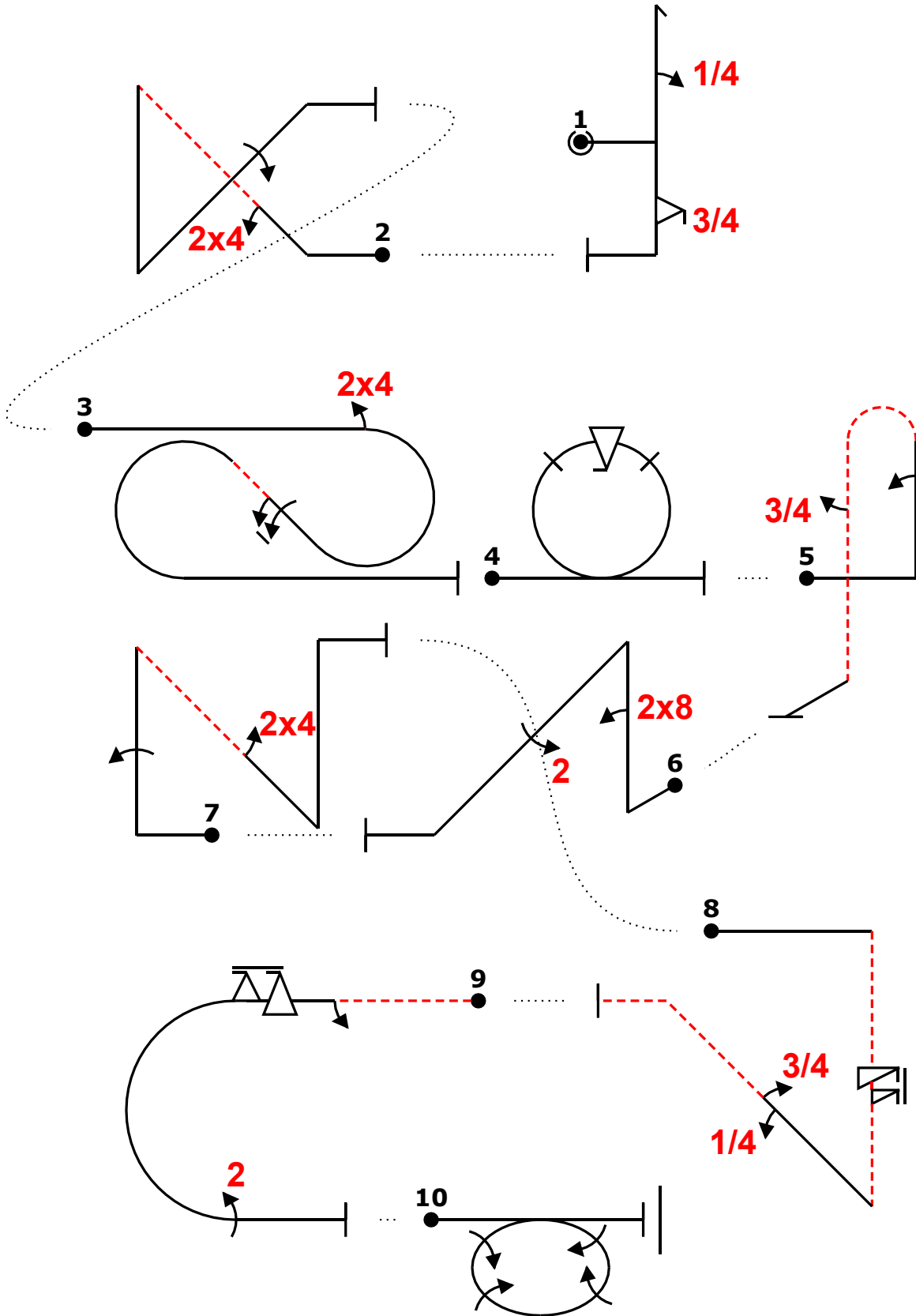
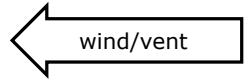

Power			
Fig	Aresti	K	
1 A	5.2.1.1	17	34
	9.1.1.1	6	
	9.9.5.3	11	
2 E	1.3.2.1	18	35
	9.4.2.2	7	
	9.1.2.4	10	
3 C	7.5.5.3	15	32
	9.4.3.2	5	
	9.1.2.6	12	
4	7.4.1.1	10	21
	9.9.3.4	11	
5 D	8.4.3.1	15	29
	9.1.1.2	8	
	9.1.5.3	6	
6	1.2.6.1	14	30
	9.8.1.1	7	
	9.2.4.4	9	
7	1.3.12.1	21	38
	9.1.1.4	12	
	9.4.4.2	5	
8 B	1.2.8.3	15	30
	9.11.1.6	3	
	9.1.2.1	4	
	9.1.2.3	8	
9	7.2.1.4	6	33
	9.1.3.2	4	
	9.9.3.6	14	
	9.2.3.4	9	
10	2.4.7.1	38	38
Total K = 320 (max K = 320)			

Camilo Benito Pilot
AVA432 F-PRNJ A/C

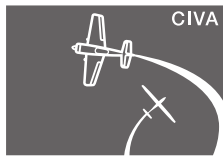

CIVA

FAI

AEROBATICS
COMMISSION

CF1 2020

Form C

Pilot ID

CIVA Advanced Programme1

Flight #

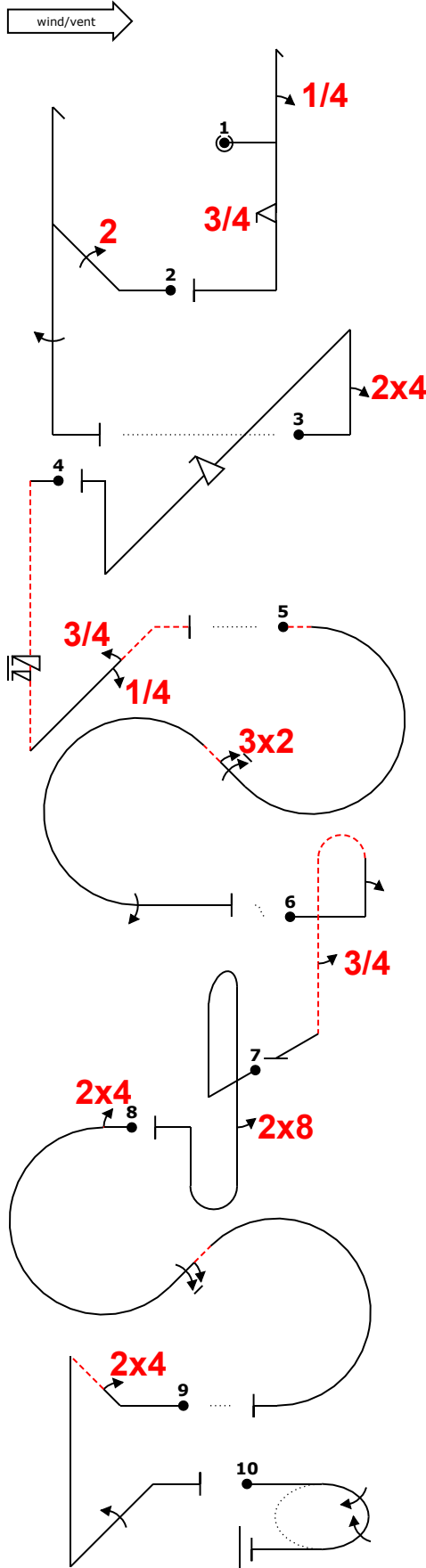

Power			
Fig	Aresti	K	
1 A	5.2.1.1	17	34
	9.1.1.1	6	
	9.9.5.3	11	
2	5.3.1.1	18	37
	9.2.2.4	11	
	9.1.5.4	8	
3	1.3.13.1	22	42
	9.4.1.2	9	
	9.9.4.4	11	
4 B	1.2.8.3	15	30
	9.11.1.6	3	
	9.1.2.1	4	
	9.1.2.3	8	
5	7.5.2.4	15	37
	9.2.2.6	14	
	9.1.3.4	8	
6 D	8.4.3.1	15	29
	9.1.1.2	8	
	9.1.5.3	6	
7	8.8.2.1	19	22
	9.8.5.1	3	
8 C	7.5.5.3	15	32
	9.4.3.2	5	
	9.1.2.6	12	
9 E	1.3.2.1	18	35
	9.4.2.2	7	
	9.1.2.4	10	
10	2.2.5.1	22	22
Total K = 320		(max K = 320)	

Graton Pilot
EX330SC F-HODV
A/C

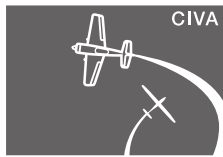

CIVA

FAI

AEROBATICS
COMMISSION

CF1 2020

Form B

Pilot ID

CIVA Advanced Programme1

Flight #

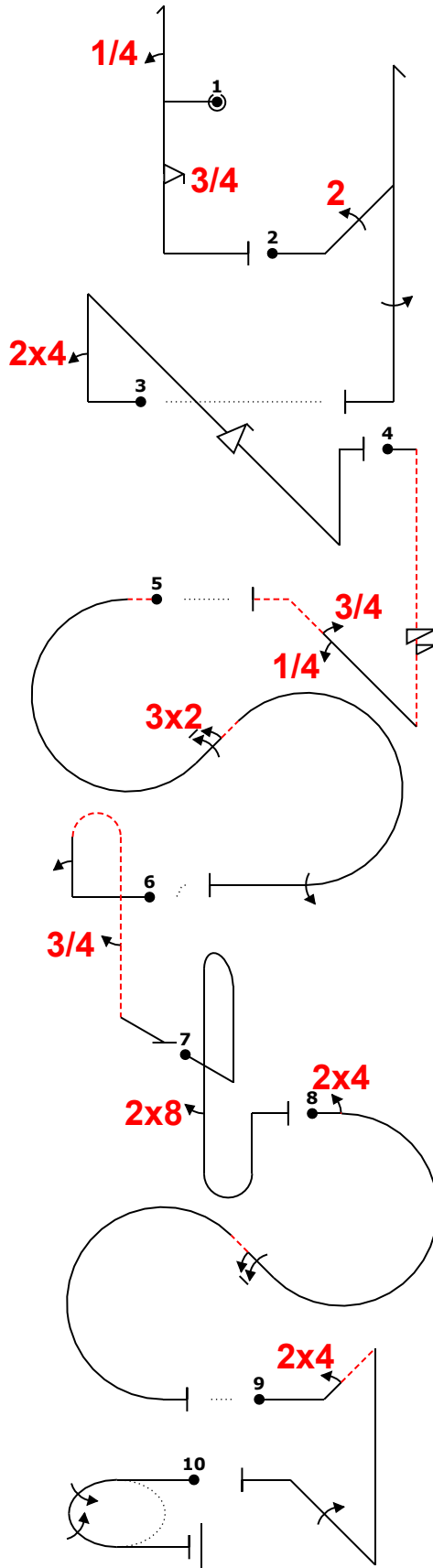
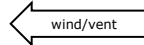

Power			
Fig	Aresti	K	
1 A	5.2.1.1	17	34
	9.1.1.1	6	
	9.9.5.3	11	
2	5.3.1.1	18	37
	9.2.2.4	11	
	9.1.5.4	8	
3	1.3.13.1	22	42
	9.4.1.2	9	
	9.9.4.4	11	
4 B	1.2.8.3	15	30
	9.11.1.6	3	
	9.1.2.1	4	
	9.1.2.3	8	
5	7.5.2.4	15	37
	9.2.2.6	14	
	9.1.3.4	8	
6 D	8.4.3.1	15	29
	9.1.1.2	8	
	9.1.5.3	6	
	9.1.5.3	6	
7	8.8.2.1	19	22
	9.8.5.1	3	
	9.8.5.1	3	
8 C	7.5.5.3	15	32
	9.4.3.2	5	
	9.1.2.6	12	
	9.1.2.6	12	
9 E	1.3.2.1	18	35
	9.4.2.2	7	
	9.1.2.4	10	
10	2.2.5.1	22	22
Total K = 320 (max K = 320)			

Graton Pilot
EX330SC F-HODV
A/C

Pilot ID

Flight #

CIVA Advanced Free Known

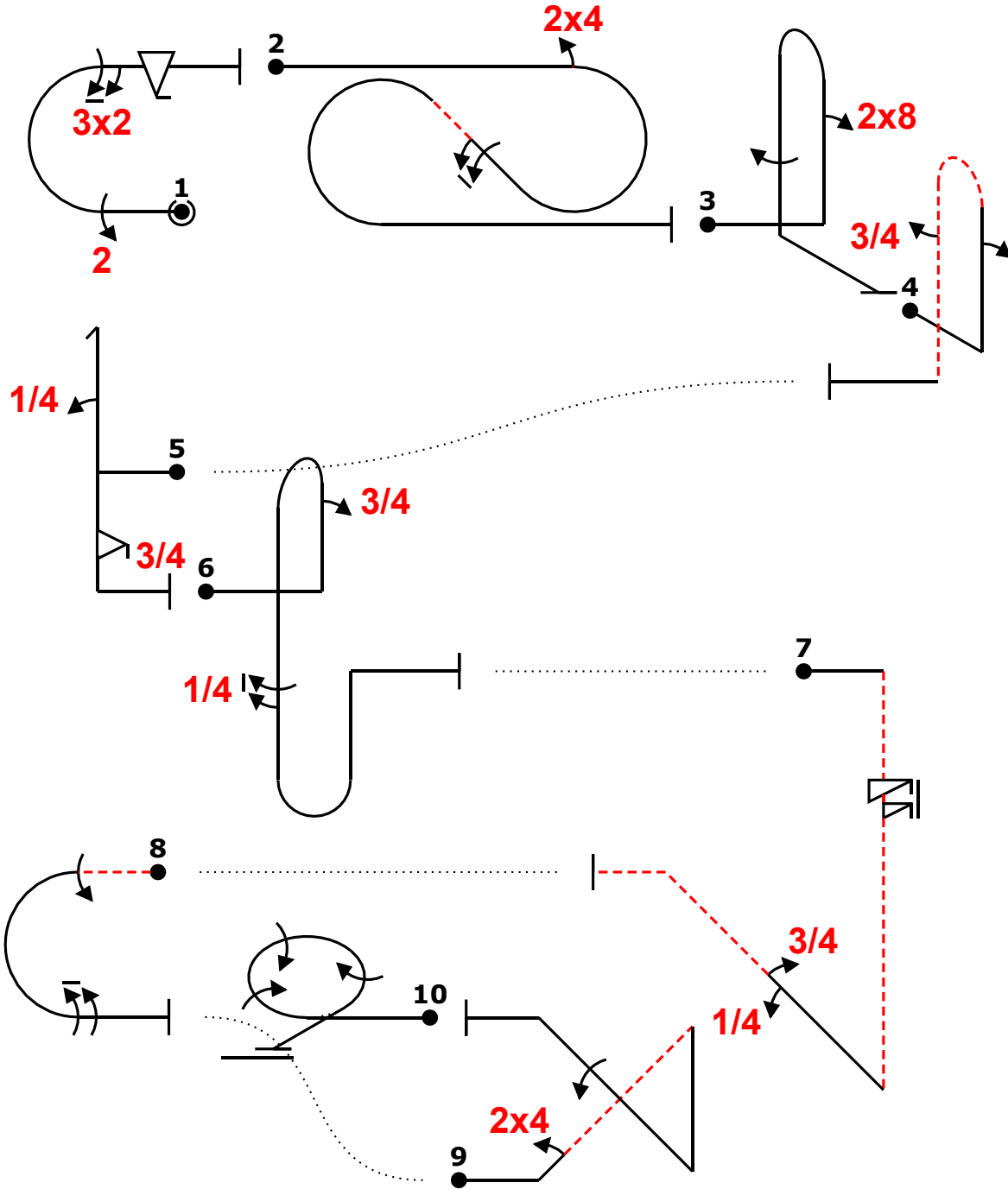
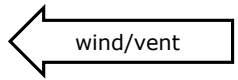

Power			
Fig	Aresti	K	
1	7.2.2.1	6	38
	9.2.3.4	9	
	9.2.3.6	12	
	9.9.3.4	11	
2 C	7.5.5.3	15	32
	9.4.3.2	5	
	9.1.2.6	12	
3	8.4.1.1	13	28
	9.8.1.1	7	
	9.1.5.4	8	
4 D	8.4.3.1	15	29
	9.1.1.2	8	
	9.1.5.3	6	
5 A	5.2.1.1	17	34
	9.1.1.1	6	
	9.9.5.3	11	
6	8.8.2.1	19	38
	9.1.1.3	10	
	9.1.5.5	9	
7 B	1.2.8.3	15	30
	9.11.1.6	3	
	9.1.2.1	4	
	9.1.2.3	8	
8	7.2.1.4	6	26
	9.1.3.4	8	
	9.1.3.8	12	
9 E	1.3.2.1	18	35
	9.4.2.2	7	
	9.1.2.4	10	
10	2.3.4.1	30	30
Total K = 320 (max K = 320)			

CYS Pilot
EXTRA 330SC F-HLAS
A/C

Pilot ID

Flight #

CIVA Advanced Free Known

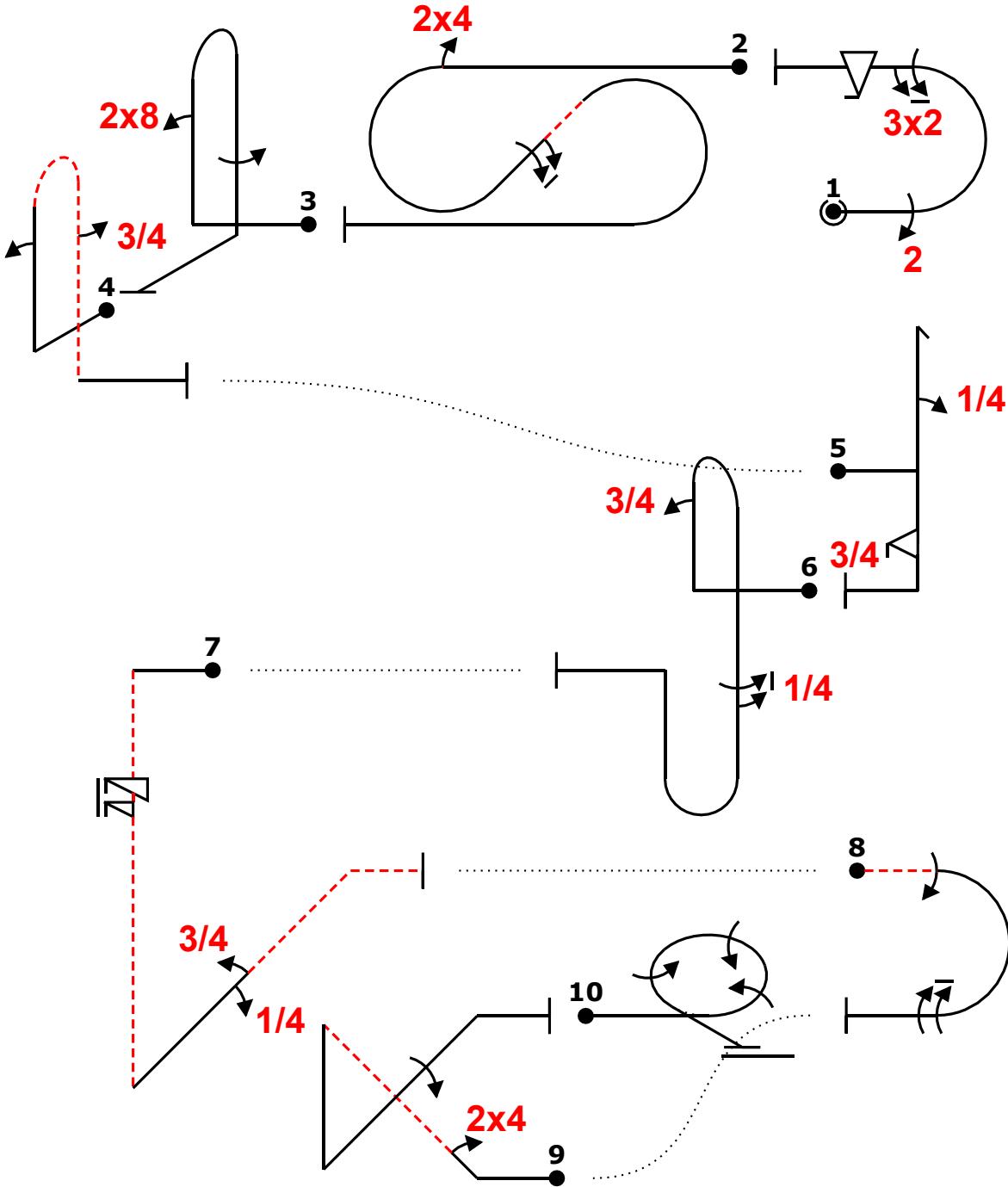
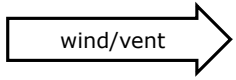

Power			
Fig	Aresti	K	
1	7.2.2.1	6	38
	9.2.3.4	9	
	9.2.3.6	12	
	9.9.3.4	11	
2 C	7.5.5.3	15	32
	9.4.3.2	5	
	9.1.2.6	12	
3	8.4.1.1	13	28
	9.8.1.1	7	
	9.1.5.4	8	
4 D	8.4.3.1	15	29
	9.1.1.2	8	
	9.1.5.3	6	
5 A	5.2.1.1	17	34
	9.1.1.1	6	
	9.9.5.3	11	
6	8.8.2.1	19	38
	9.1.1.3	10	
	9.1.5.5	9	
7 B	1.2.8.3	15	30
	9.11.1.6	3	
	9.1.2.1	4	
	9.1.2.3	8	
8	7.2.1.4	6	26
	9.1.3.4	8	
	9.1.3.8	12	
9 E	1.3.2.1	18	35
	9.4.2.2	7	
	9.1.2.4	10	
10	2.3.4.1	30	30
Total K = 320 (max K = 320)			

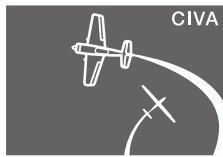

CIVA

FAI

AEROBATICS
COMMISSION

Pilot ID

CIVA Advanced Programme1

Form B

Flight #

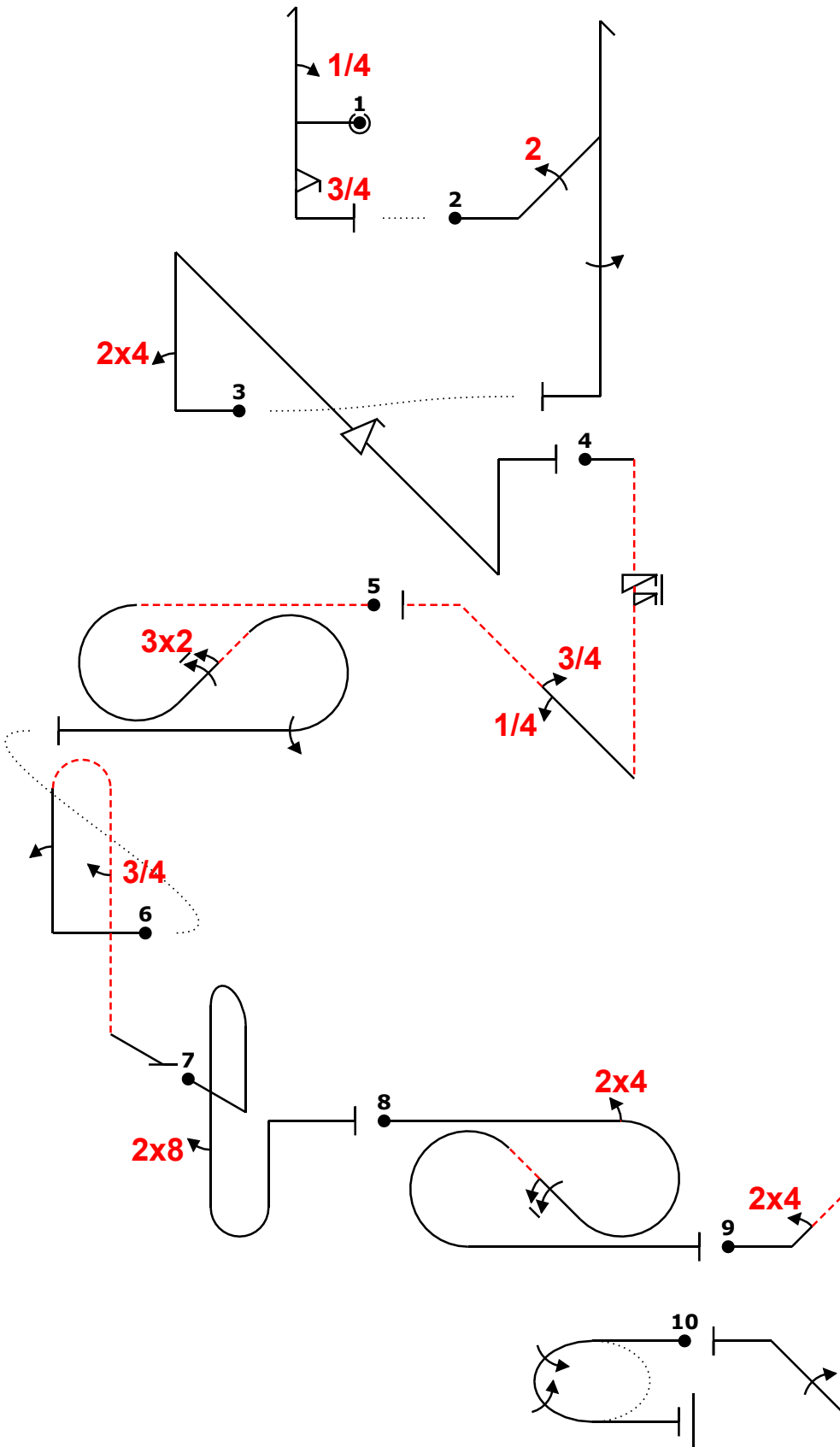
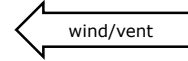

Power			
Fig	Aresti	K	
1 A	5.2.1.1	17	34
	9.1.1.1	6	
	9.9.5.3	11	
2	5.3.1.1	18	37
	9.2.2.4	11	
	9.1.5.4	8	
3	1.3.13.1	22	42
	9.4.1.2	9	
	9.9.4.4	11	
4 B	1.2.8.3	15	30
	9.11.1.6	3	
	9.1.2.1	4	
	9.1.2.3	8	
5	7.5.2.4	15	37
	9.2.2.6	14	
	9.1.3.4	8	
6 D	8.4.3.1	15	29
	9.1.1.2	8	
	9.1.5.3	6	
7	8.8.2.1	19	22
	9.8.5.1	3	
8 C	7.5.5.3	15	32
	9.4.3.2	5	
	9.1.2.6	12	
9 E	1.3.2.1	18	35
	9.4.2.2	7	
	9.1.2.4	10	
10	2.2.5.1	22	22
Total K = 320 (max K = 320)			

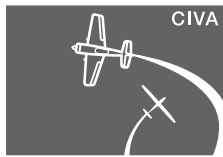

FAI

AEROBATICS
COMMISSION

Pilot ID

CIVA Advanced Programme1

Form C

Flight #

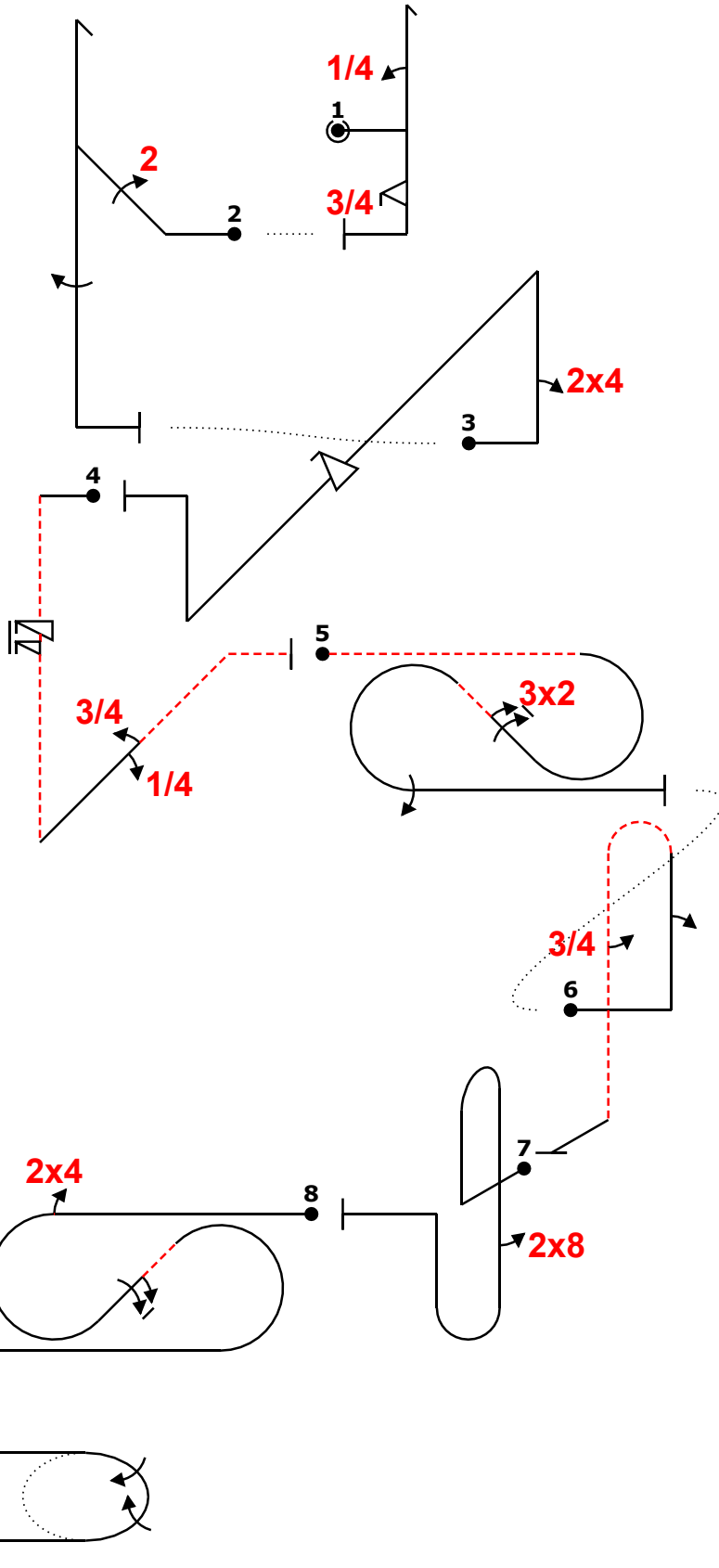
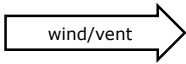

Power			
Fig	Aresti	K	
1 A	5.2.1.1	17	34
	9.1.1.1	6	
	9.9.5.3	11	
2	5.3.1.1	18	37
	9.2.2.4	11	
	9.1.5.4	8	
3	1.3.13.1	22	42
	9.4.1.2	9	
	9.9.4.4	11	
4 B	1.2.8.3	15	30
	9.11.1.6	3	
	9.1.2.1	4	
	9.1.2.3	8	
5	7.5.2.4	15	37
	9.2.2.6	14	
	9.1.3.4	8	
6 D	8.4.3.1	15	29
	9.1.1.2	8	
	9.1.5.3	6	
7	8.8.2.1	19	22
8 C	7.5.5.3	15	32
	9.4.3.2	5	
	9.1.2.6	12	
9 E	1.3.2.1	18	35
	9.4.2.2	7	
	9.1.2.4	10	
10	2.2.5.1	22	22
Total K = 320 (max K = 320)			

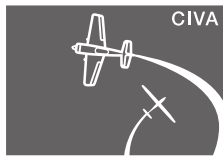

CIVA

FAI

AEROBATICS
COMMISSION

Pilot ID

CIVA Advanced Programme1

Form B

Flight #

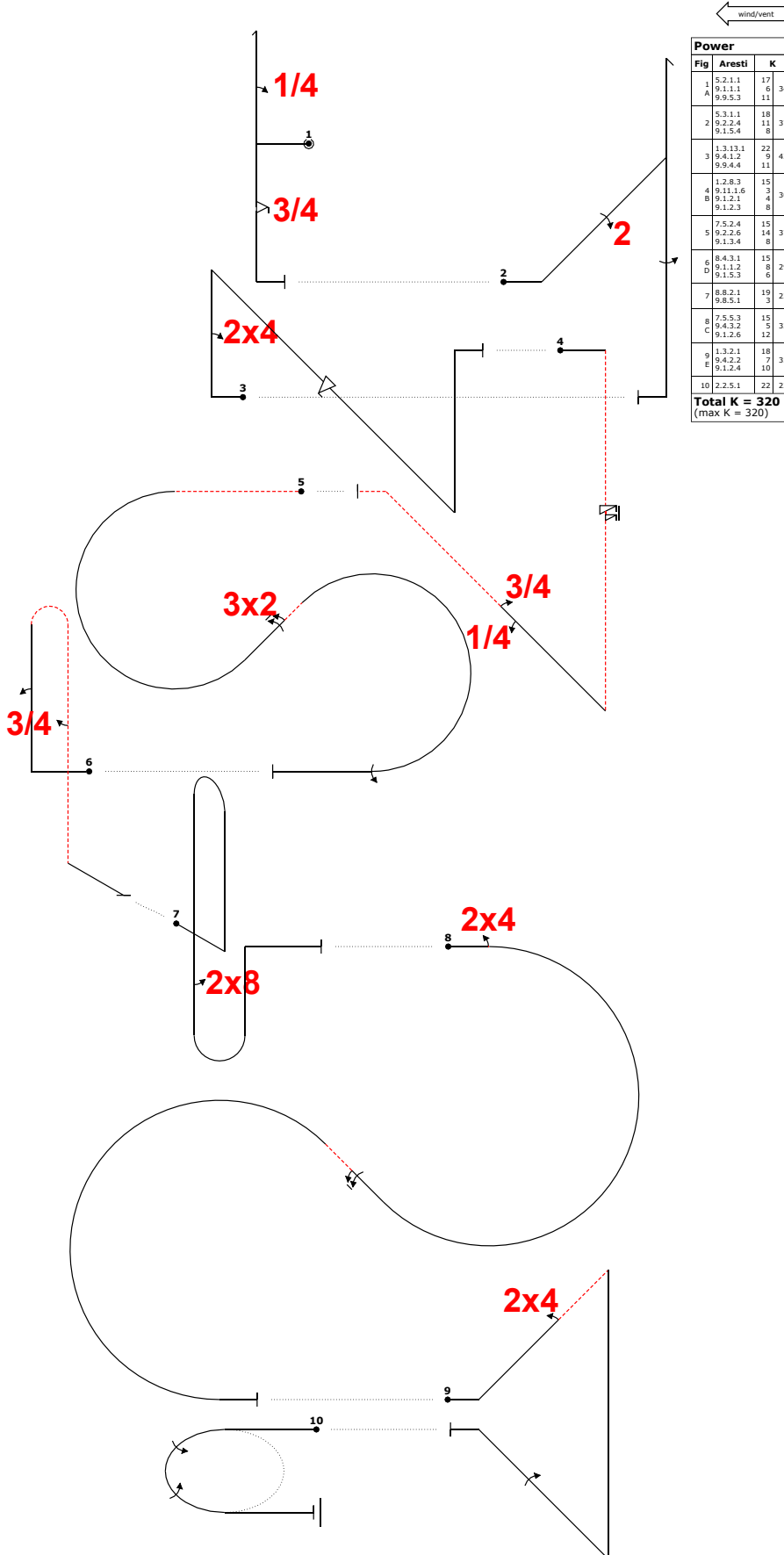

Check: 17-9-2020 1:03 OpenAero 2020.1.9 2020 civa advanced programme1 Sequence is correct

GREGORY FROMONT
Pilot
CAP 232 F-HKIF
A/C

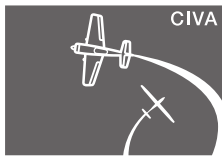

CIVA

FAI

AEROBATICS
COMMISSION

Pilot ID

CIVA Advanced Programme1

Form C

Flight #

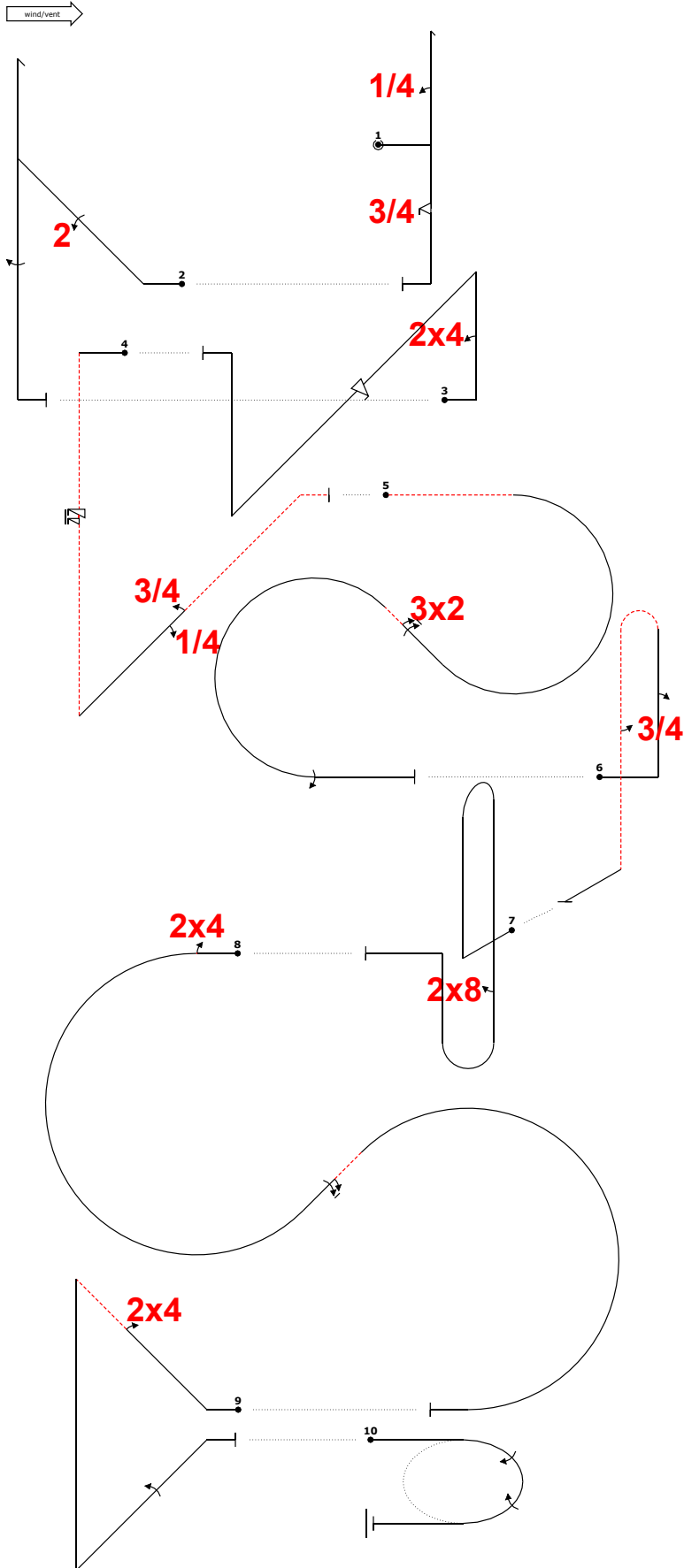

Power		
Fig	Aresti	K
1 A	5.2.1.1	17
	9.1.1.1	6
	9.9.5.3	11
2	5.3.1.1	18
	9.2.2.4	13
	9.1.5.4	8
3	1.3.13.1	22
	9.4.1.2	9
	9.9.4.4	11
4 B	1.2.8.3	15
	9.1.1.6	3
	9.1.2.1	4
5	9.1.2.3	8
	7.5.2.4	15
	9.2.2.6	14
6 D	9.1.3.4	8
	8.4.3.1	15
	9.1.1.2	8
7	9.1.5.3	6
	8.8.2.1	19
	9.8.5.1	3
8 C	7.5.5.3	15
	9.4.3.2	5
	9.1.2.6	12
9 E	1.3.2.1	16
	9.4.2.2	7
	9.1.2.4	10
10	2.2.5.1	22
Total K = 320		22
(max K = 320)		

Check: 17-9-2020 1:03 OpenAero 2020.1.9 2020 civa advanced programme1 Sequence is correct

GREGORY FROMONT
Pilot
CAP 232 F-HKIF
A/C

		Form B
Pilot ID	France Advanced connu-libre	
	Flight #	

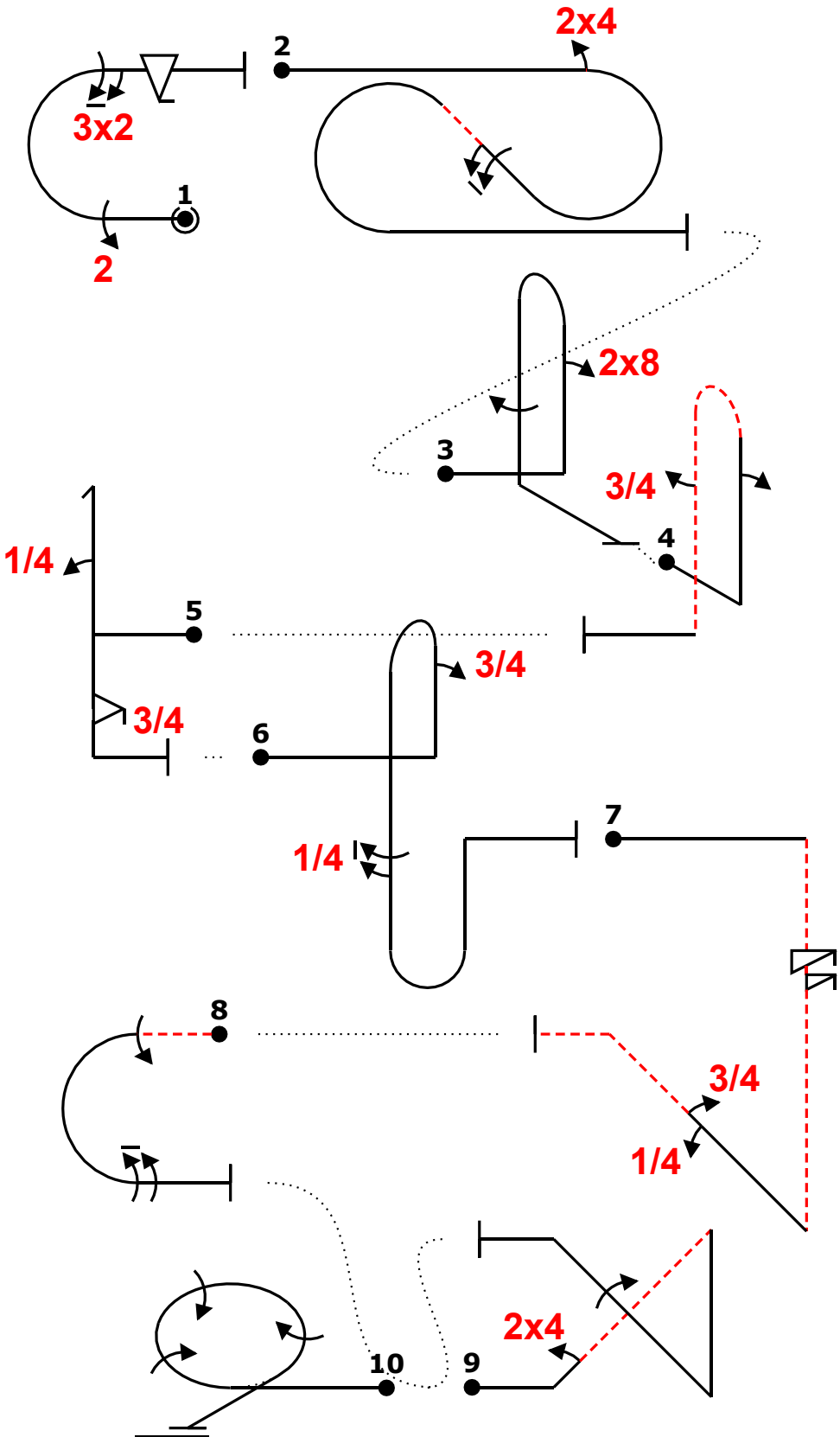
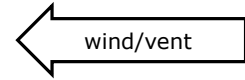

Power			
Fig	Aresti	K	
1	7.2.2.1	6	38
	9.2.3.4	9	
	9.2.3.6	12	
	9.9.3.4	11	
2 C	7.5.5.3	15	32
	9.4.3.2	5	
	9.1.2.6	12	
3	8.4.1.1	13	28
	9.8.1.1	7	
	9.1.5.4	8	
4 D	8.4.3.1	15	29
	9.1.1.2	8	
	9.1.5.3	6	
5 A	5.2.1.1	17	34
	9.1.1.1	6	
	9.9.5.3	11	
6	8.8.2.1	19	38
	9.1.1.3	10	
	9.1.5.5	9	
7 B	1.2.8.3	15	30
	9.11.1.6	3	
	9.1.2.1	4	
	9.1.2.3	8	
8	7.2.1.4	6	26
	9.1.3.4	8	
	9.1.3.8	12	
9 E	1.3.2.1	18	35
	9.4.2.2	7	
	9.1.2.4	10	
10	2.3.4.1	30	30
Total K = 320 (max K = 320)			

Pilot ID		Form C
France Advanced connu-libre		Flight #

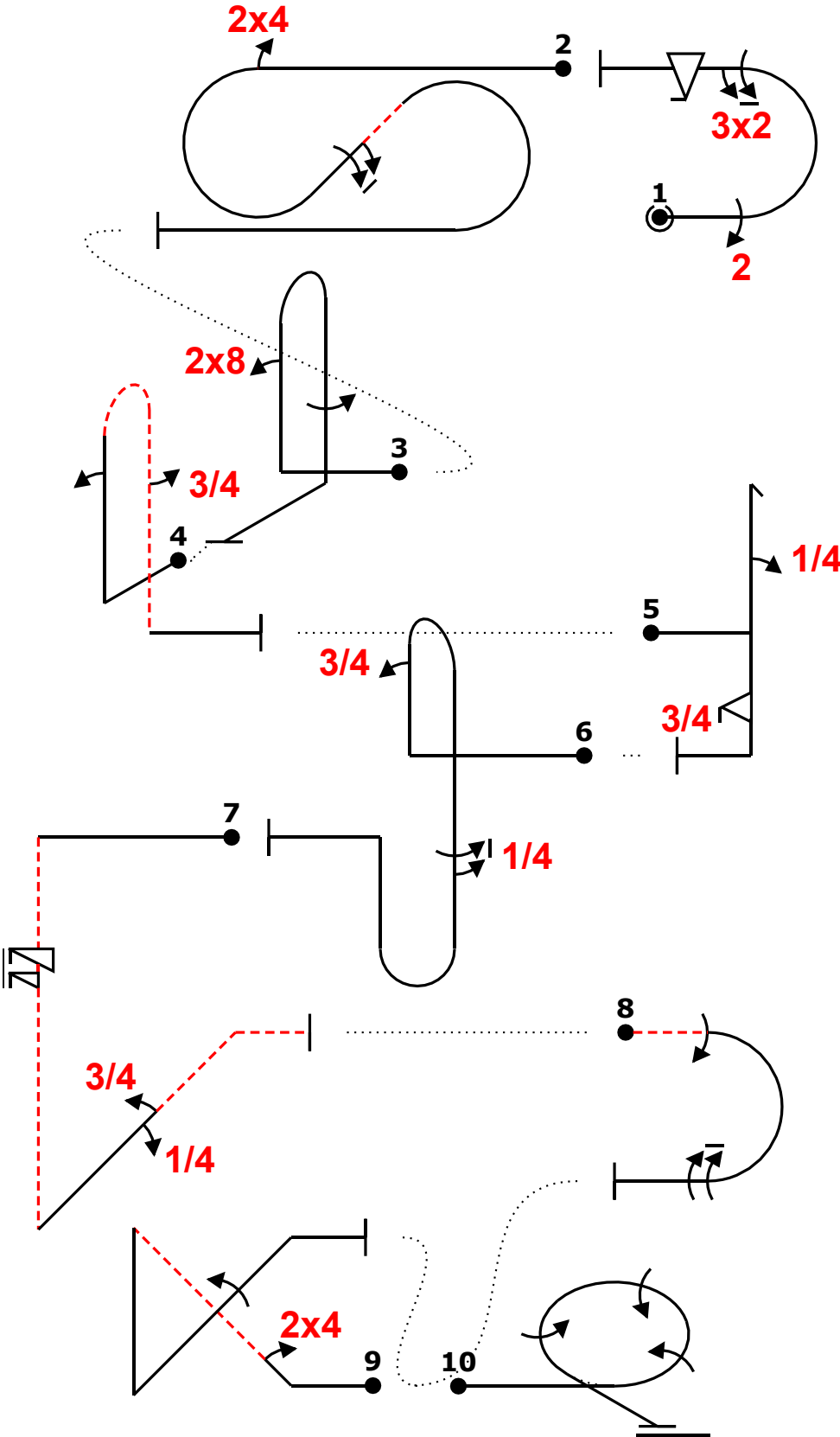
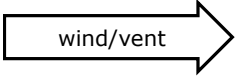

Power			
Fig	Aresti	K	
1	7.2.2.1	6	38
	9.2.3.4	9	
	9.2.3.6	12	
	9.9.3.4	11	
2 C	7.5.5.3	15	32
	9.4.3.2	5	
	9.1.2.6	12	
3	8.4.1.1	13	28
	9.8.1.1	7	
	9.1.5.4	8	
4 D	8.4.3.1	15	29
	9.1.1.2	8	
	9.1.5.3	6	
5 A	5.2.1.1	17	34
	9.1.1.1	6	
	9.9.5.3	11	
6	8.8.2.1	19	38
	9.1.1.3	10	
	9.1.5.5	9	
7 B	1.2.8.3	15	30
	9.11.1.6	3	
	9.1.2.1	4	
	9.1.2.3	8	
8	7.2.1.4	6	26
	9.1.3.4	8	
	9.1.3.8	12	
9 E	1.3.2.1	18	35
	9.4.2.2	7	
	9.1.2.4	10	
10	2.3.4.1	30	30
Total K = 320		(max K = 320)	

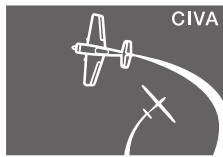

FAI

AEROBATICS
COMMISSION

CF1/CHATEAUROUX SEPTEMBRE 2020

Form B

Pilot ID

Flight #

CIVA Advanced Free Known

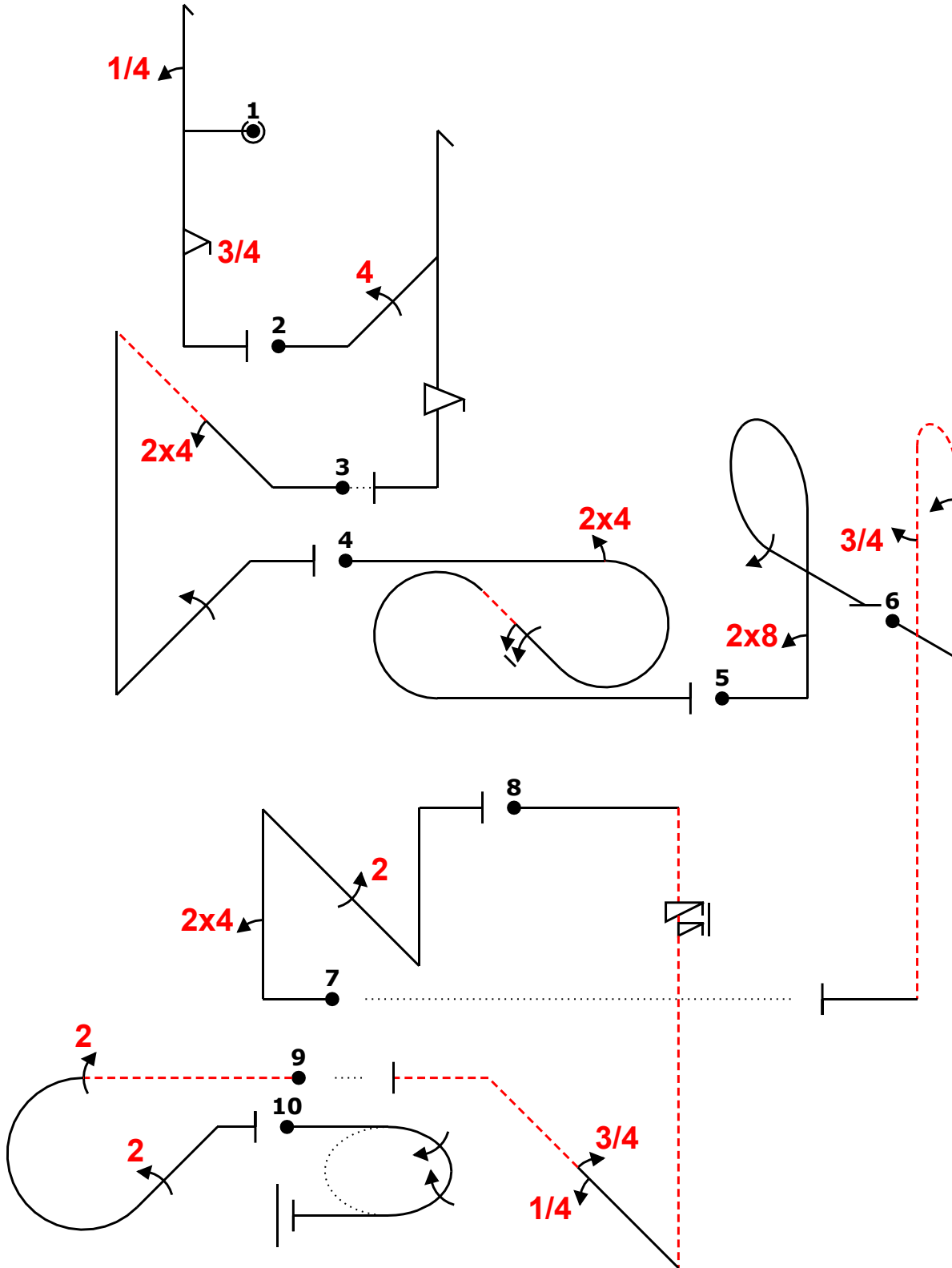
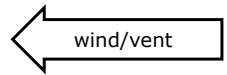

Power			
Fig	Aresti	K	
1 A	5.2.1.1	17	34
	9.1.1.1	6	
	9.9.5.3	11	
2	5.3.1.1	18	42
	9.4.2.4	13	
	9.9.5.4	11	
3 E	1.3.2.1	18	35
	9.4.2.2	7	
	9.1.2.4	10	
4 C	7.5.5.3	15	32
	9.4.3.2	5	
	9.1.2.6	12	
5	8.6.1.1	11	26
	9.8.1.1	7	
	9.1.3.4	8	
6 D	8.4.3.1	15	29
	9.1.1.2	8	
	9.1.5.3	6	
7	1.3.13.1	22	40
	9.4.1.2	9	
	9.2.4.4	9	
8 B	1.2.8.3	15	30
	9.11.1.6	3	
	9.1.2.1	4	
	9.1.2.3	8	
9	8.5.5.4	10	30
	9.2.3.4	9	
	9.2.2.4	11	
10	2.2.5.1	22	22
Total K = 320 (max K = 320)			

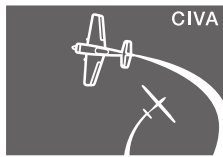

FAI AEROBATICS COMMISSION

CF1/CHATEAUROUX SEPTEMBRE 2020		Form C
Pilot ID	CIVA Advanced Free Known	
	Flight #	

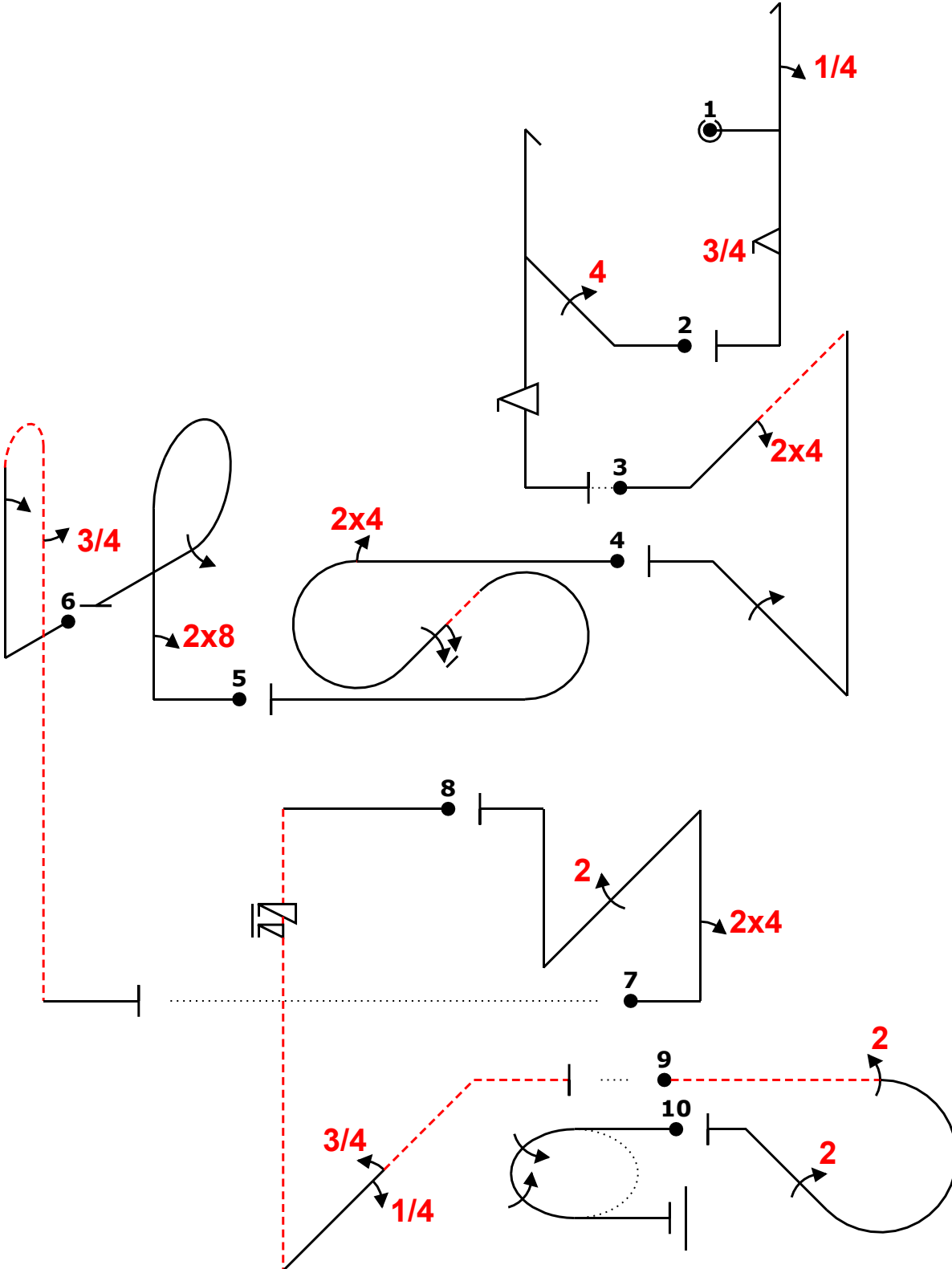
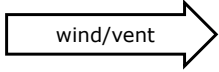

Power			
Fig	Aresti	K	
1 A	5.2.1.1	17	34
	9.1.1.1	6	
	9.9.5.3	11	
2	5.3.1.1	18	42
	9.4.2.4	13	
	9.9.5.4	11	
3 E	1.3.2.1	18	35
	9.4.2.2	7	
	9.1.2.4	10	
4 C	7.5.5.3	15	32
	9.4.3.2	5	
	9.1.2.6	12	
5	8.6.1.1	11	26
	9.8.1.1	7	
	9.1.3.4	8	
6 D	8.4.3.1	15	29
	9.1.1.2	8	
	9.1.5.3	6	
7	1.3.13.1	22	40
	9.4.1.2	9	
	9.2.4.4	9	
8 B	1.2.8.3	15	30
	9.11.1.6	3	
	9.1.2.1	4	
	9.1.2.3	8	
9	8.5.5.4	10	30
	9.2.3.4	9	
	9.2.2.4	11	
10	2.2.5.1	22	22
Total K = 320 (max K = 320)			

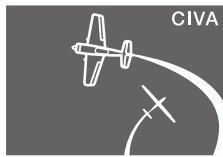

CIVA

FAI

AEROBATICS
COMMISSION

CF1 Septembre 2020

Form B

Pilot ID

CIVA Advanced Programme1

Flight #

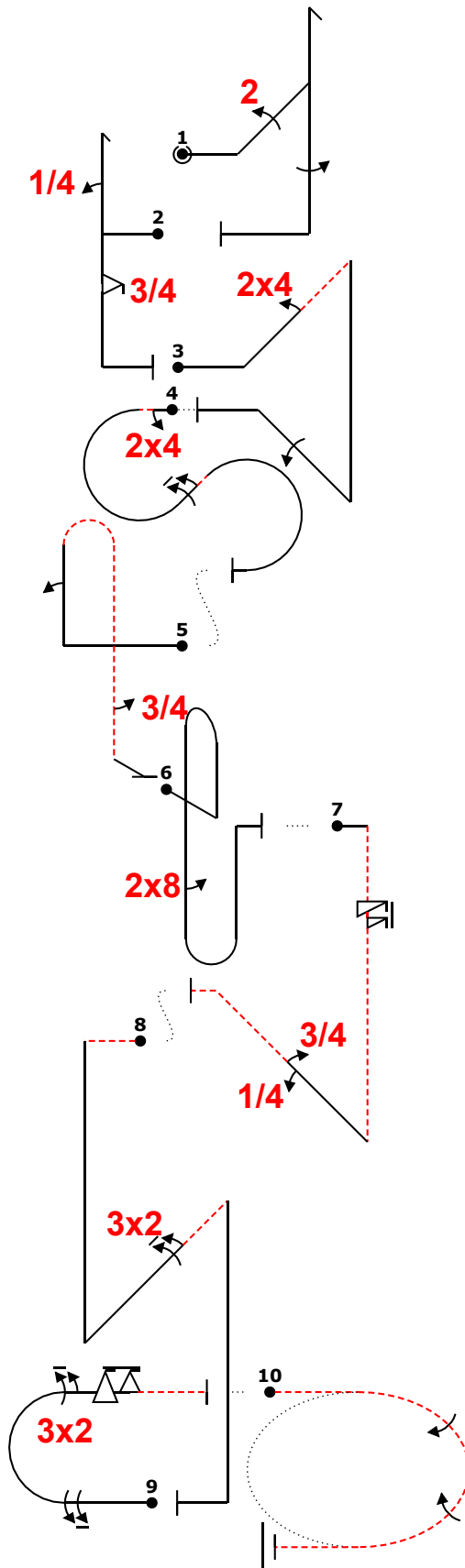
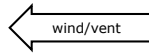

Power			
Fig	Aresti	K	
1	5.3.1.1	18	37
	9.2.2.4	11	
	9.1.5.4	8	
2 A	5.2.1.1	17	34
	9.1.1.1	6	
	9.9.5.3	11	
3 E	1.3.2.1	18	35
	9.4.2.2	7	
	9.1.2.4	10	
4 C	7.5.5.3	15	32
	9.4.3.2	5	
	9.1.2.6	12	
5 D	8.4.3.1	15	29
	9.1.1.2	8	
	9.1.5.3	6	
6	8.8.2.1	19	22
	9.8.5.1	3	
7 B	1.2.8.3	15	30
	9.11.1.6	3	
	9.1.2.1	4	
	9.1.2.3	8	
8	1.3.11.4	20	34
	9.2.2.6	14	
9	7.2.1.1	6	44
	9.1.3.8	12	
	9.2.3.6	12	
	9.9.3.6	14	
10	2.2.5.2	23	23
Total K = 320 (max K = 320)			

Audrey Pilot
Extra F HDBV A/C

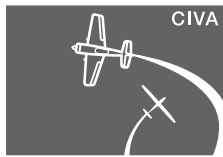

FAI

AEROBATICS
COMMISSION

CF1 Septembre 2020

Form C

Pilot ID

CIVA Advanced Programme1

Flight #

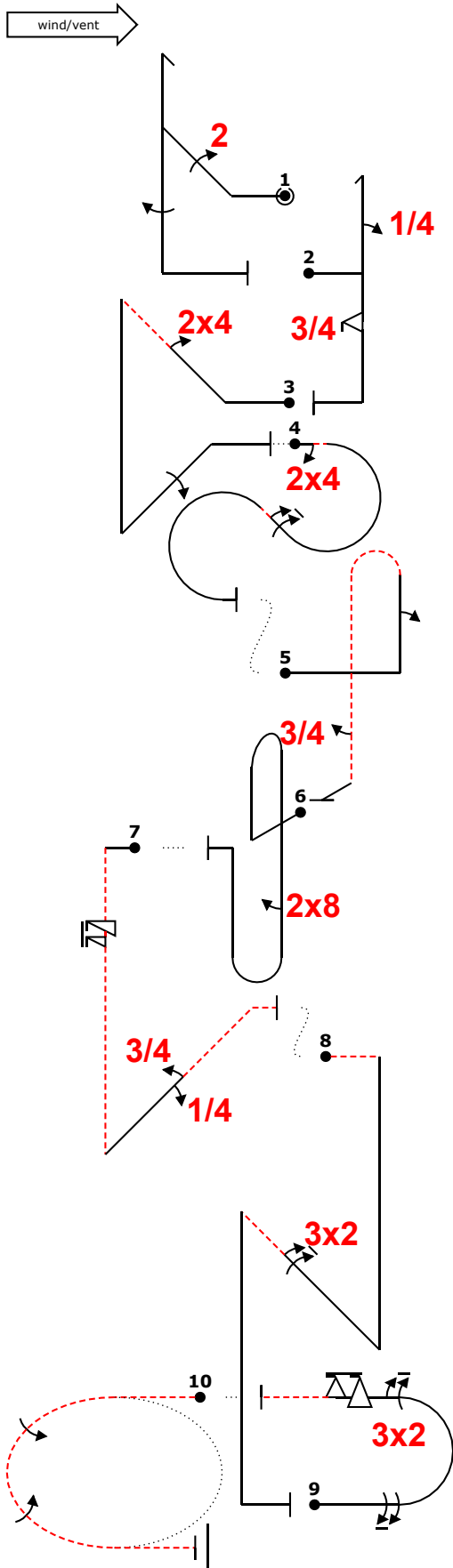

Power		
Fig	Aresti	K
1	5.3.1.1	18
	9.2.2.4	11
	9.1.5.4	8
2 A	5.2.1.1	17
	9.1.1.1	6
	9.9.5.3	11
3 E	1.3.2.1	18
	9.4.2.2	7
	9.1.2.4	10
4 C	7.5.5.3	15
	9.4.3.2	5
	9.1.2.6	12
5 D	8.4.3.1	15
	9.1.1.2	8
	9.1.5.3	6
6	8.8.2.1	19
	9.8.5.1	3
7 B	1.2.8.3	15
	9.11.1.6	3
	9.1.2.1	4
	9.1.2.3	8
8	1.3.11.4	20
	9.2.2.6	14
9	7.2.1.1	6
	9.1.3.8	12
	9.2.3.6	12
	9.9.3.6	14
10	2.2.5.2	23
	23	23
Total K = 320		
(max K = 320)		

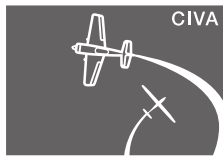

CIVA

FAI

AEROBATICS
COMMISSION

Form B

Pilot ID

CIVA Advanced Programme1

Flight #

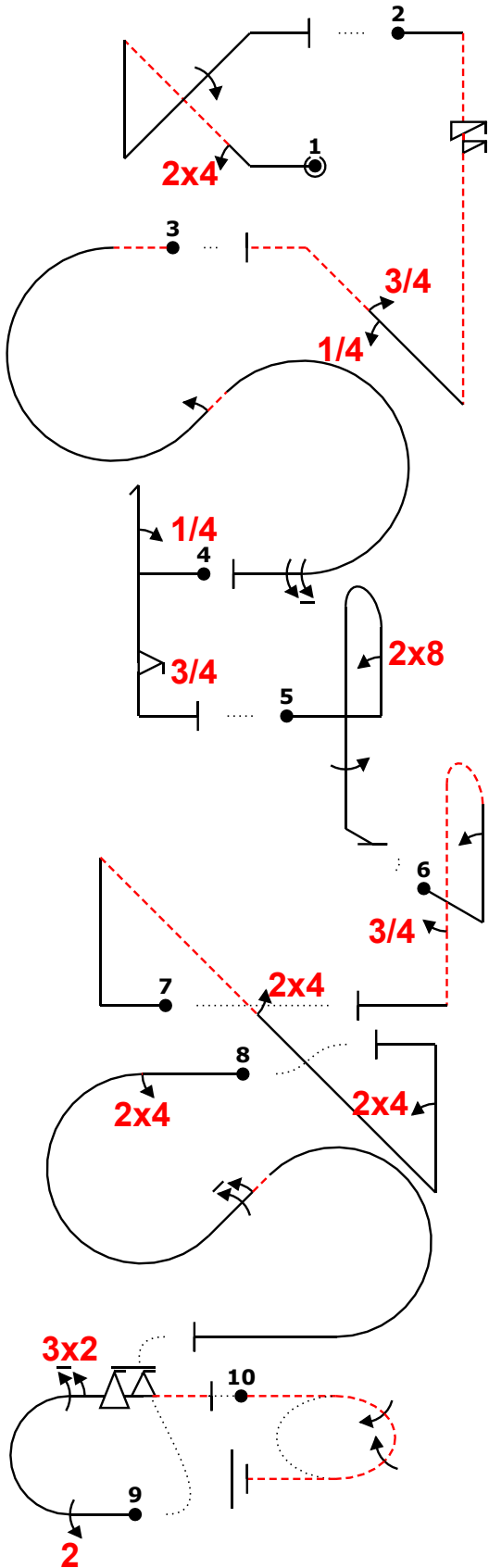
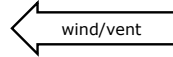

Power			
Fig	Aresti	K	
1 E	1.3.2.1	18	35
	9.4.2.2	7	
	9.1.2.4	10	
2 B	1.2.8.3	15	30
	9.11.1.6	3	
	9.1.2.1	4	
3	7.5.2.4	15	33
	9.1.2.2	6	
	9.1.3.8	12	
4 A	5.2.1.1	17	34
	9.1.1.1	6	
	9.9.5.3	11	
5	8.4.1.1	13	28
	9.8.1.1	7	
	9.1.5.4	8	
6 D	8.4.3.1	15	29
	9.1.1.2	8	
	9.1.5.3	6	
7	1.3.12.1	21	35
	9.4.4.2	5	
	9.4.1.2	9	
8 C	7.5.5.3	15	32
	9.4.3.2	5	
	9.1.2.6	12	
9	7.2.1.1	6	41
	9.2.3.4	9	
	9.2.3.6	12	
	9.9.3.6	14	
10	2.2.5.2	23	23
Total K = 320		(max K = 320)	

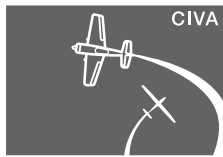

FAI

AEROBATICS
COMMISSION

Pilot ID

CIVA Advanced Programme1

Form C

Flight #

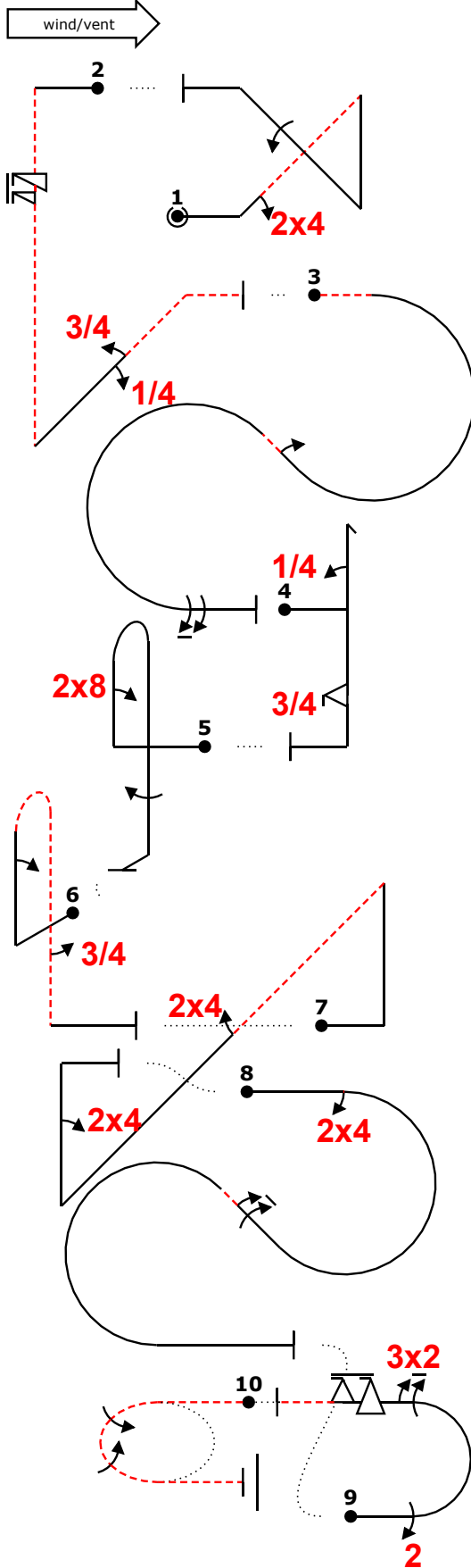

Power			
Fig	Aresti	K	
1 E	1.3.2.1	18	35
	9.4.2.2	7	
	9.1.2.4	10	
2 B	1.2.8.3	15	30
	9.11.1.6	3	
	9.1.2.1	4	
3	7.5.2.4	15	33
	9.1.2.2	6	
	9.1.3.8	12	
4 A	5.2.1.1	17	34
	9.1.1.1	6	
	9.9.5.3	11	
5	8.4.1.1	13	28
	9.8.1.1	7	
	9.1.5.4	8	
6 D	8.4.3.1	15	29
	9.1.1.2	8	
	9.1.5.3	6	
7	1.3.12.1	21	35
	9.4.4.2	5	
	9.4.1.2	9	
8 C	7.5.5.3	15	32
	9.4.3.2	5	
	9.1.2.6	12	
9	7.2.1.1	6	41
	9.2.3.4	9	
	9.2.3.6	12	
	9.9.3.6	14	
10	2.2.5.2	23	23
Total K = 320 (max K = 320)			

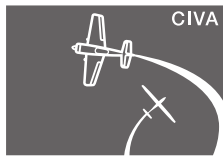

CIVA

FAI

AEROBATICS
COMMISSION

Form B

Pilot ID

CIVA Advanced Programme1

Flight #

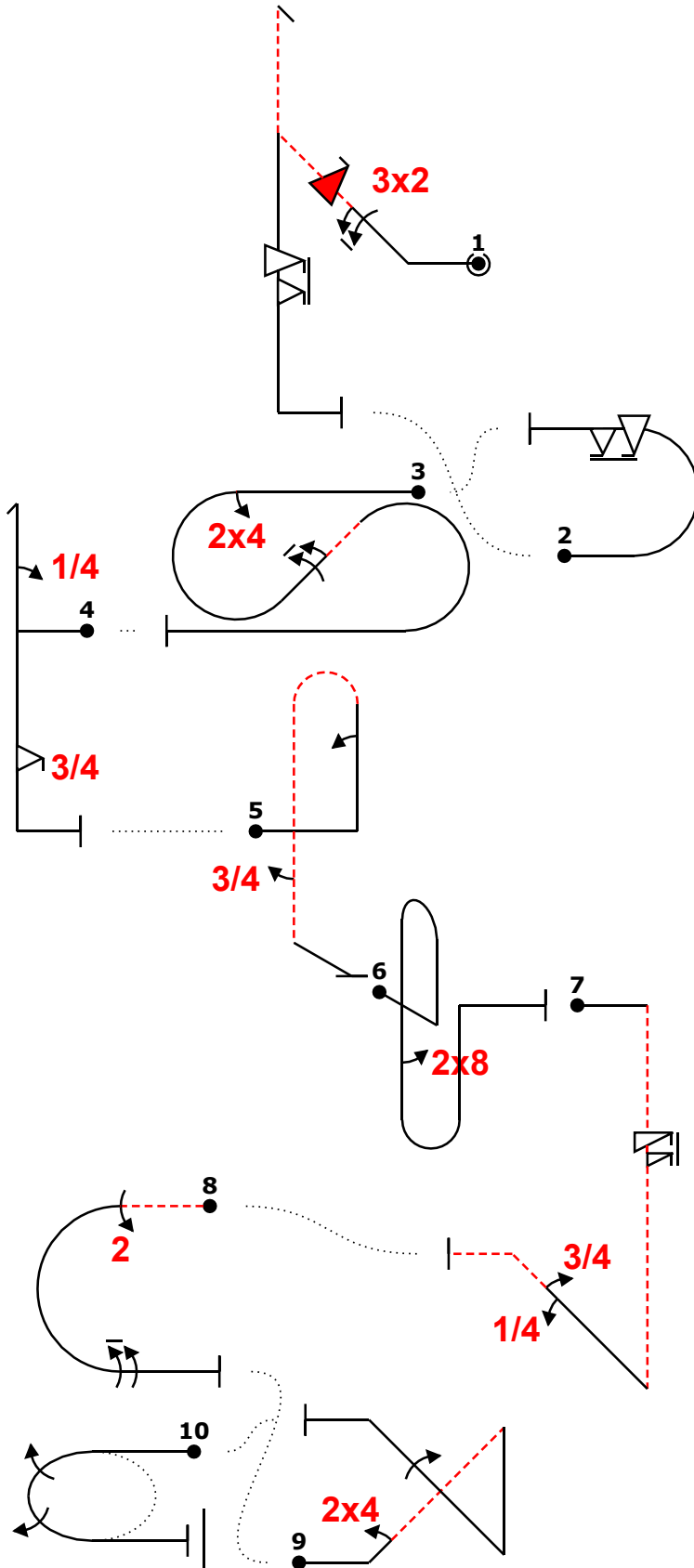
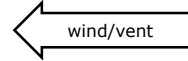

Power			
Fig	Aresti	K	
1	5.3.2.1	24	67
	9.2.2.6	14	
	9.10.2.4	15	
	9.9.5.6	14	
2	7.2.2.1	6	20
	9.9.3.6	14	
3 C	7.5.5.3	15	32
	9.4.3.2	5	
	9.1.2.6	12	
4 A	5.2.1.1	17	34
	9.1.1.1	6	
	9.9.5.3	11	
5 D	8.4.3.1	15	29
	9.1.1.2	8	
	9.1.5.3	6	
6	8.8.2.1	19	22
	9.8.5.1	3	
7 B	1.2.8.3	15	30
	9.11.1.6	3	
	9.1.2.1	4	
	9.1.2.3	8	
8	7.2.1.4	6	27
	9.2.3.4	9	
	9.1.3.8	12	
9 E	1.3.2.1	18	35
	9.4.2.2	7	
	9.1.2.4	10	
10	2.2.5.3	24	24
Total K = 320 (max K = 320)			

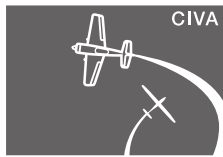

FAI

AEROBATICS
COMMISSION

Pilot ID

CIVA Advanced Programme1

Form C

Flight #

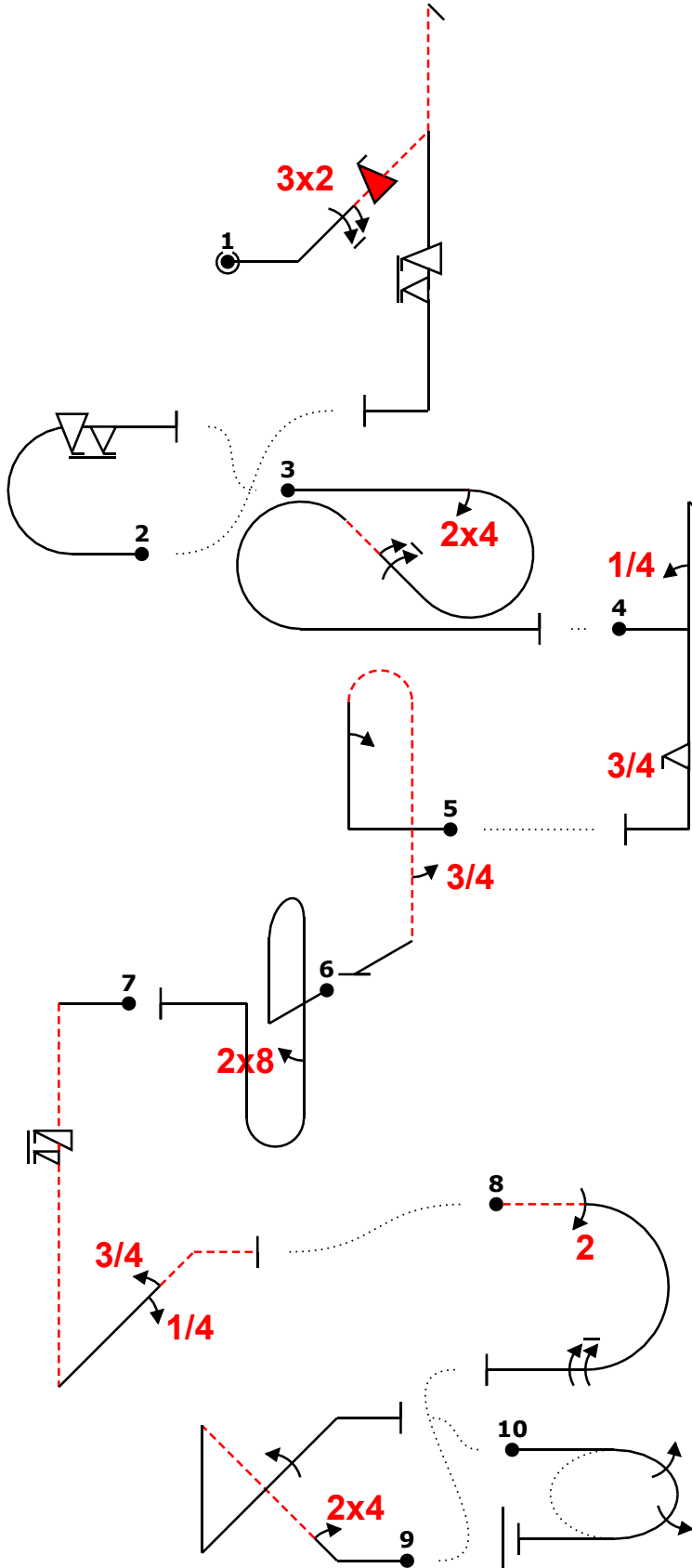
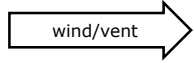

Power			
Fig	Aresti	K	
1	5.3.2.1	24	67
	9.2.2.6	14	
	9.10.2.4	15	
	9.9.5.6	14	
2	7.2.2.1	6	20
	9.9.3.6	14	
3 C	7.5.5.3	15	32
	9.4.3.2	5	
	9.1.2.6	12	
4 A	5.2.1.1	17	34
	9.1.1.1	6	
	9.9.5.3	11	
5 D	8.4.3.1	15	29
	9.1.1.2	8	
	9.1.5.3	6	
6	8.8.2.1	19	22
	9.8.5.1	3	
7 B	1.2.8.3	15	30
	9.11.1.6	3	
	9.1.2.1	4	
	9.1.2.3	8	
8	7.2.1.4	6	27
	9.2.3.4	9	
	9.1.3.8	12	
9 E	1.3.2.1	18	35
	9.4.2.2	7	
	9.1.2.4	10	
10	2.2.5.3	24	24
Total K = 320 (max K = 320)			

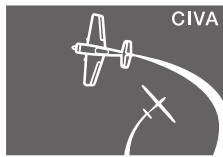

FAI

AEROBATICS
COMMISSION

AMBERIEU 2019

Form B

Pilot ID

Flight #

CIVA Advanced Free Known

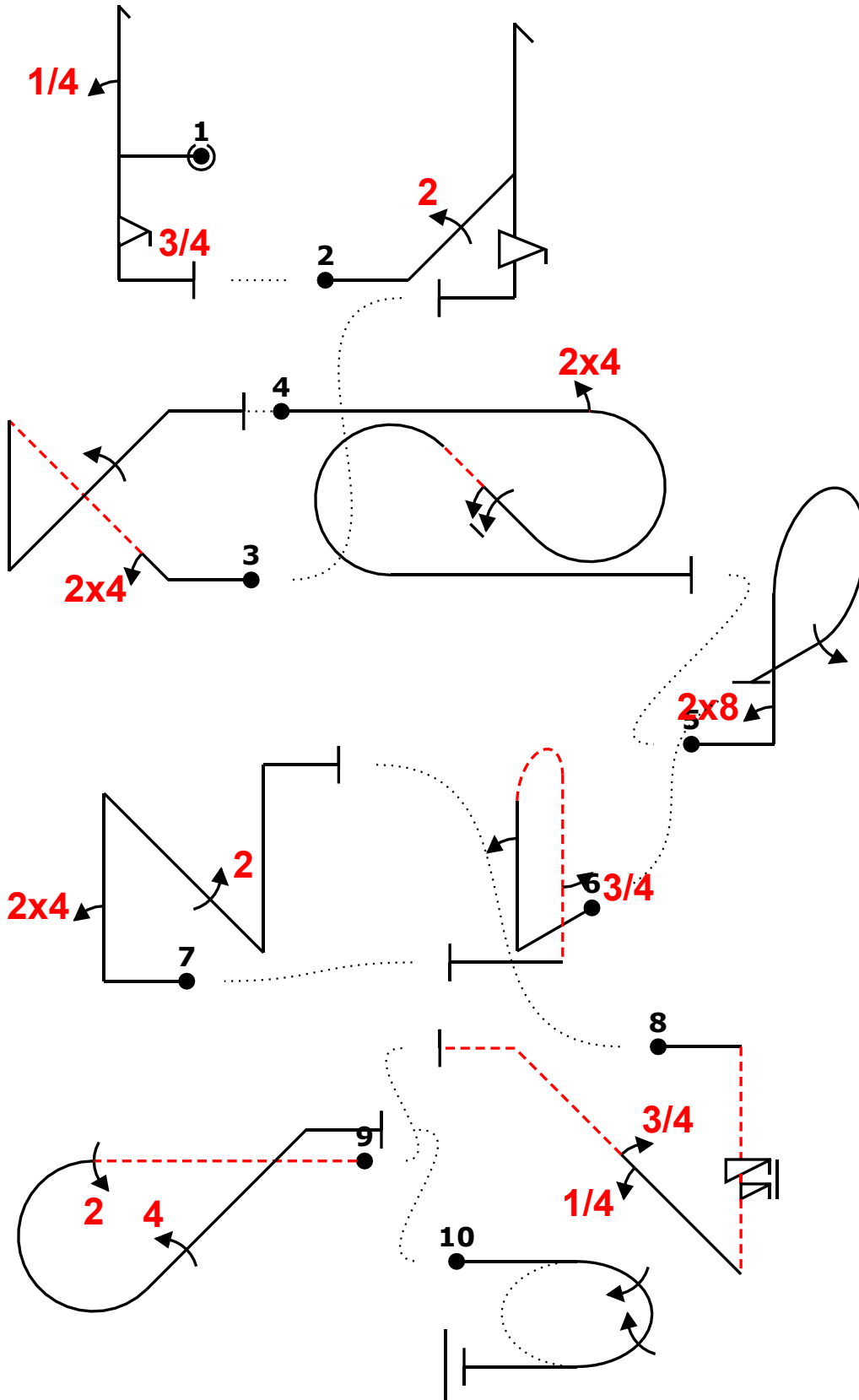
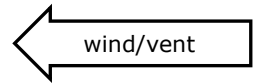

Power			
Fig	Aresti	K	
1 A	5.2.1.1	17	34
	9.1.1.1	6	
	9.9.5.3	11	
2	5.3.1.1	18	40
	9.2.2.4	11	
	9.9.5.4	11	
3 E	1.3.2.1	18	35
	9.4.2.2	7	
	9.1.2.4	10	
4 C	7.5.5.3	15	32
	9.4.3.2	5	
	9.1.2.6	12	
5	8.6.1.1	11	26
	9.8.1.1	7	
	9.1.3.4	8	
6 D	8.4.3.1	15	29
	9.1.1.2	8	
	9.1.5.3	6	
7	1.3.13.1	22	40
	9.4.1.2	9	
	9.2.4.4	9	
8 B	1.2.8.3	15	30
	9.11.1.6	3	
	9.1.2.1	4	
9	8.5.5.4	10	32
	9.2.3.4	9	
	9.4.2.4	13	
10	2.2.5.1	22	22
Total K = 320 (max K = 320)			

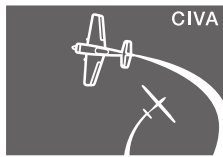

FAI

AEROBATICS
COMMISSION

AMBERIEU 2019

Form C

Pilot ID

CIVA Advanced Free Known

Flight #

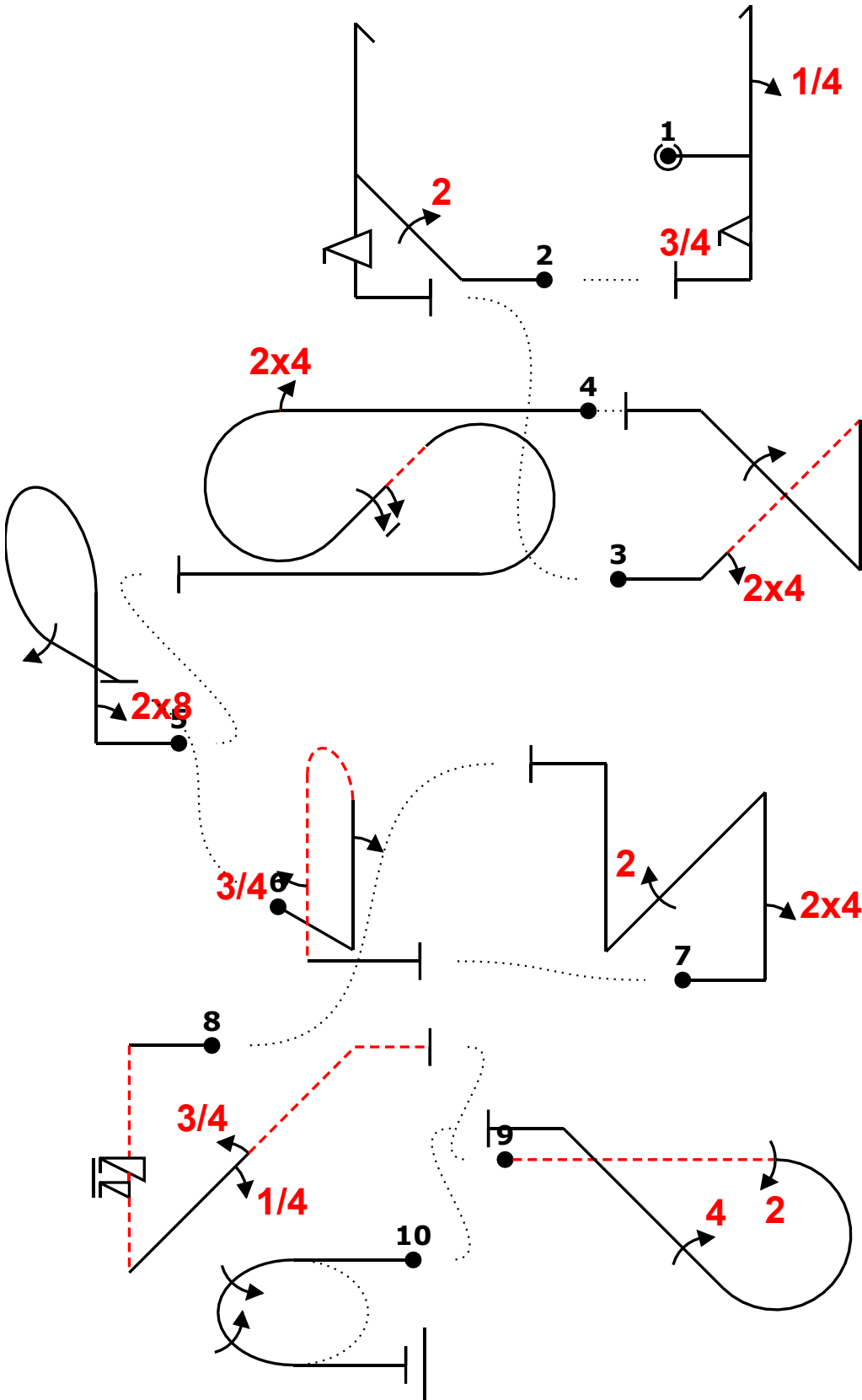
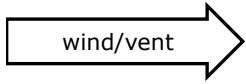

Power			
Fig	Aresti	K	
1 A	5.2.1.1	17	34
	9.1.1.1	6	
	9.9.5.3	11	
2	5.3.1.1	18	40
	9.2.2.4	11	
	9.9.5.4	11	
3 E	1.3.2.1	18	35
	9.4.2.2	7	
	9.1.2.4	10	
4 C	7.5.5.3	15	32
	9.4.3.2	5	
	9.1.2.6	12	
5	8.6.1.1	11	26
	9.8.1.1	7	
	9.1.3.4	8	
6 D	8.4.3.1	15	29
	9.1.1.2	8	
	9.1.5.3	6	
7	1.3.13.1	22	40
	9.4.1.2	9	
	9.2.4.4	9	
8 B	1.2.8.3	15	30
	9.11.1.6	3	
	9.1.2.1	4	
	9.1.2.3	8	
9	8.5.5.4	10	32
	9.2.3.4	9	
	9.4.2.4	13	
10	2.2.5.1	22	22
Total K = 320 (max K = 320)			

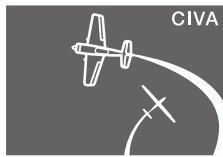

FAI

AEROBATICS
COMMISSION

Form B

Pilot ID

CIVA Advanced Programme1

Flight #

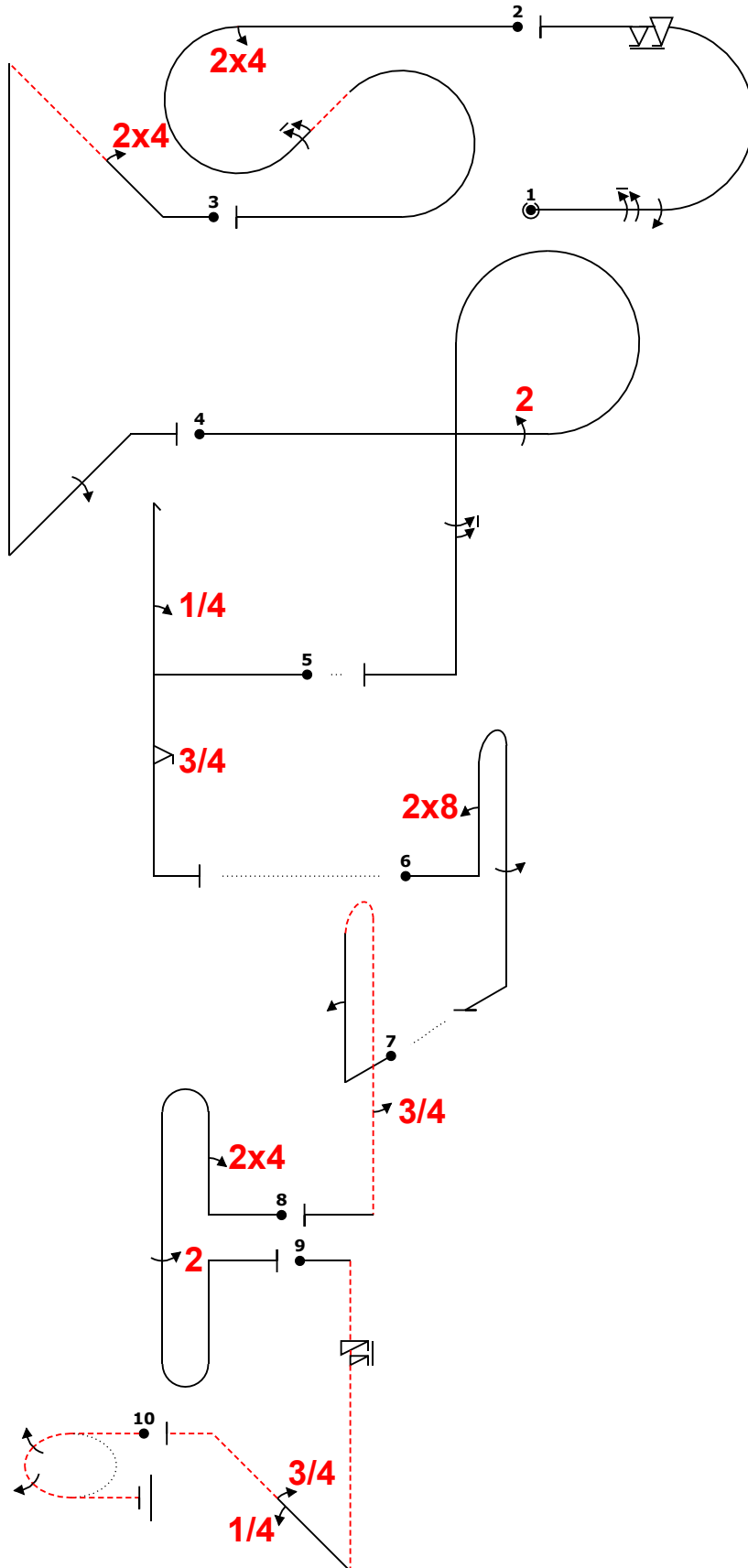
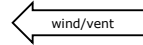

Power			
Fig	Aresti	K	
1	7.2.2.1	6	40
	9.1.3.8	12	
	9.1.3.4	8	
	9.9.3.6	14	
2 C	7.5.5.3	15	32
	9.4.3.2	5	
	9.1.2.6	12	
3 E	1.3.2.1	18	35
	9.4.2.2	7	
	9.1.2.4	10	
4	8.6.5.1	11	30
	9.2.3.4	9	
	9.1.5.6	10	
5 A	5.2.1.1	17	34
	9.1.1.1	6	
	9.9.5.3	11	
6	8.4.1.1	13	28
	9.8.1.1	7	
	9.1.5.4	8	
7 D	8.4.3.1	15	29
	9.1.1.2	8	
	9.1.5.3	6	
8	8.8.2.1	19	37
	9.4.1.2	9	
	9.2.5.4	9	
9 B	1.2.8.3	15	30
	9.11.1.6	3	
	9.1.2.1	4	
	9.1.2.3	8	
10	2.2.5.4	25	25
Total K = 320		(max K = 320)	

Robyn Picard Pilot
XA42 F-HPAR A/C

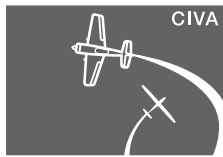

FAI

AEROBATICS
COMMISSION

Pilot ID

CIVA Advanced Programme1

Form C

Flight #

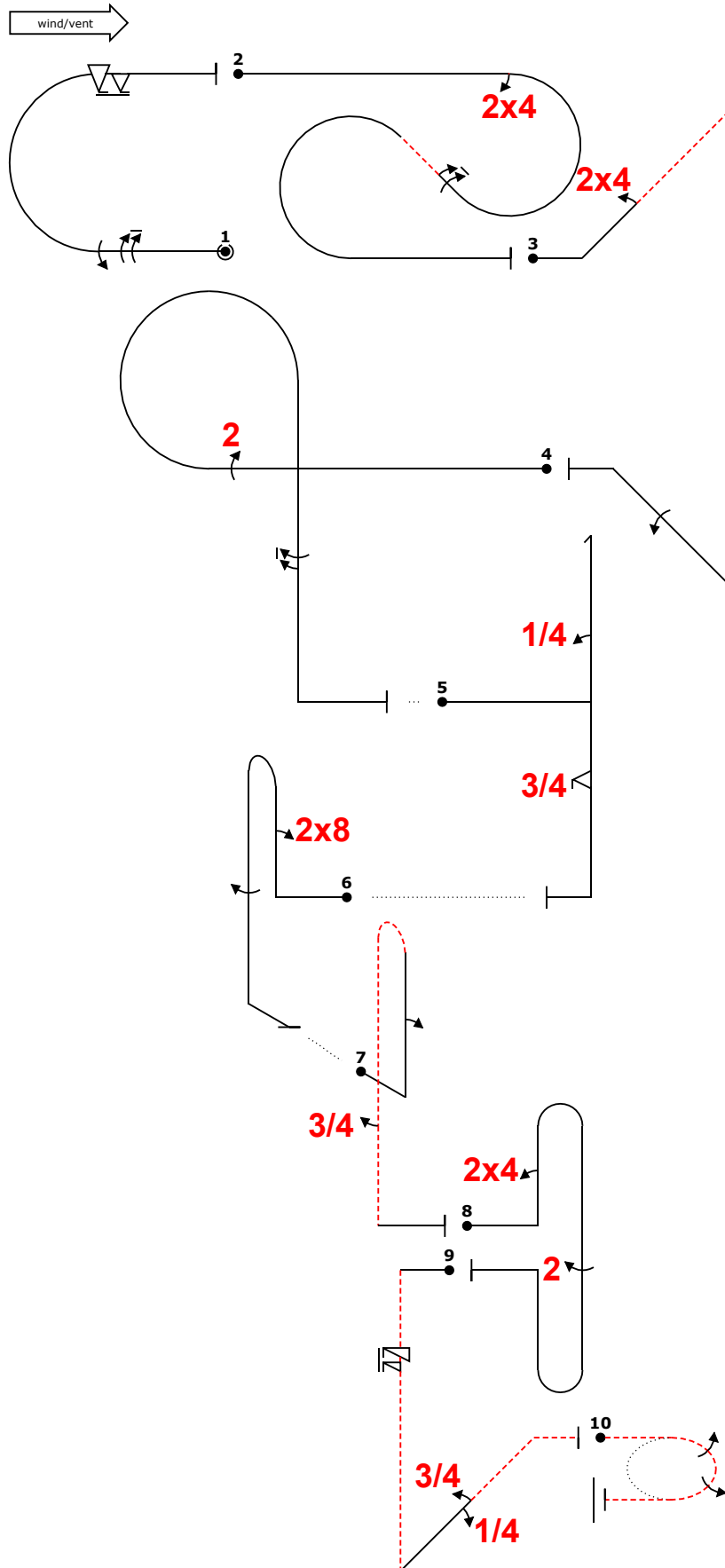

Power		
Fig	Aresti	K
1	7.2.2.1	6
	9.1.3.8	12
	9.1.3.4	8
	9.9.3.6	14
2 C	7.5.5.3	15
	9.4.3.2	5
	9.1.2.6	12
3 E	1.3.2.1	18
	9.4.2.2	7
	9.1.2.4	10
4	8.6.5.1	11
	9.2.3.4	9
	9.1.5.6	10
5 A	5.2.1.1	17
	9.1.1.1	6
	9.9.5.3	11
6	8.4.1.1	13
	9.8.1.1	7
	9.1.5.4	8
7 D	8.4.3.1	15
	9.1.1.2	8
	9.1.5.3	6
8	8.8.2.1	19
	9.4.1.2	9
	9.2.5.4	9
9 B	1.2.8.3	15
	9.11.1.6	3
	9.1.2.1	4
	9.1.2.3	8
10	2.2.5.4	25
	25	25
Total K = 320		
(max K = 320)		

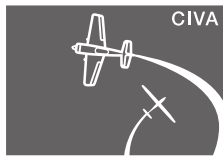

CIVA

FAI

AEROBATICS
COMMISSION

Pilot ID

CIVA Advanced Free Known

Form B

Flight #

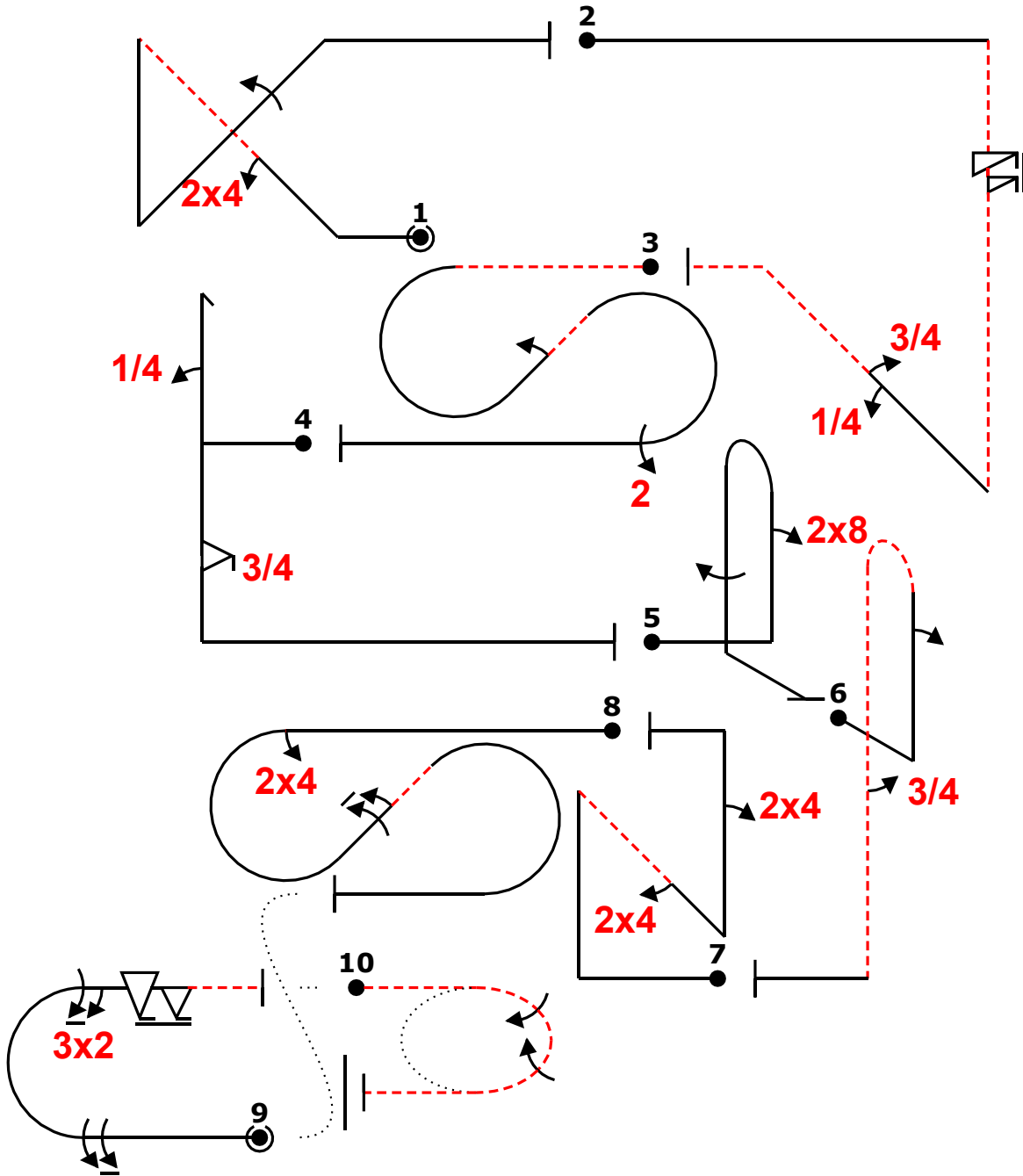
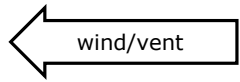

Power			
Fig	Aresti	K	
1 E	1.3.2.1	18	35
	9.4.2.2	7	
	9.1.2.4	10	
2 B	1.2.8.3	15	30
	9.1.1.1.6	3	
	9.1.2.1	4	
3	7.5.2.4	15	30
	9.1.2.2	6	
	9.2.3.4	9	
4 A	5.2.1.1	17	34
	9.1.1.1	6	
	9.9.5.3	11	
5	8.4.1.1	13	28
	9.8.1.1	7	
	9.1.5.4	8	
6 D	8.4.3.1	15	29
	9.1.1.2	8	
	9.1.5.3	6	
7	1.3.12.1	21	35
	9.4.4.2	5	
	9.4.1.2	9	
8 C	7.5.5.3	15	32
	9.4.3.2	5	
	9.1.2.6	12	
9	7.2.1.1	6	44
	9.1.3.8	12	
	9.2.3.6	12	
	9.9.3.6	14	
10	2.2.5.2	23	23
Total K = 320		(max K = 320)	

Salome GILLES Pilot
EXTRA 330 SC F-HLA A/C

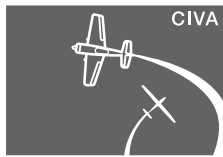

FAI

AEROBATICS
COMMISSION

Pilot ID

CIVA Advanced Free Known

Form C

Flight #

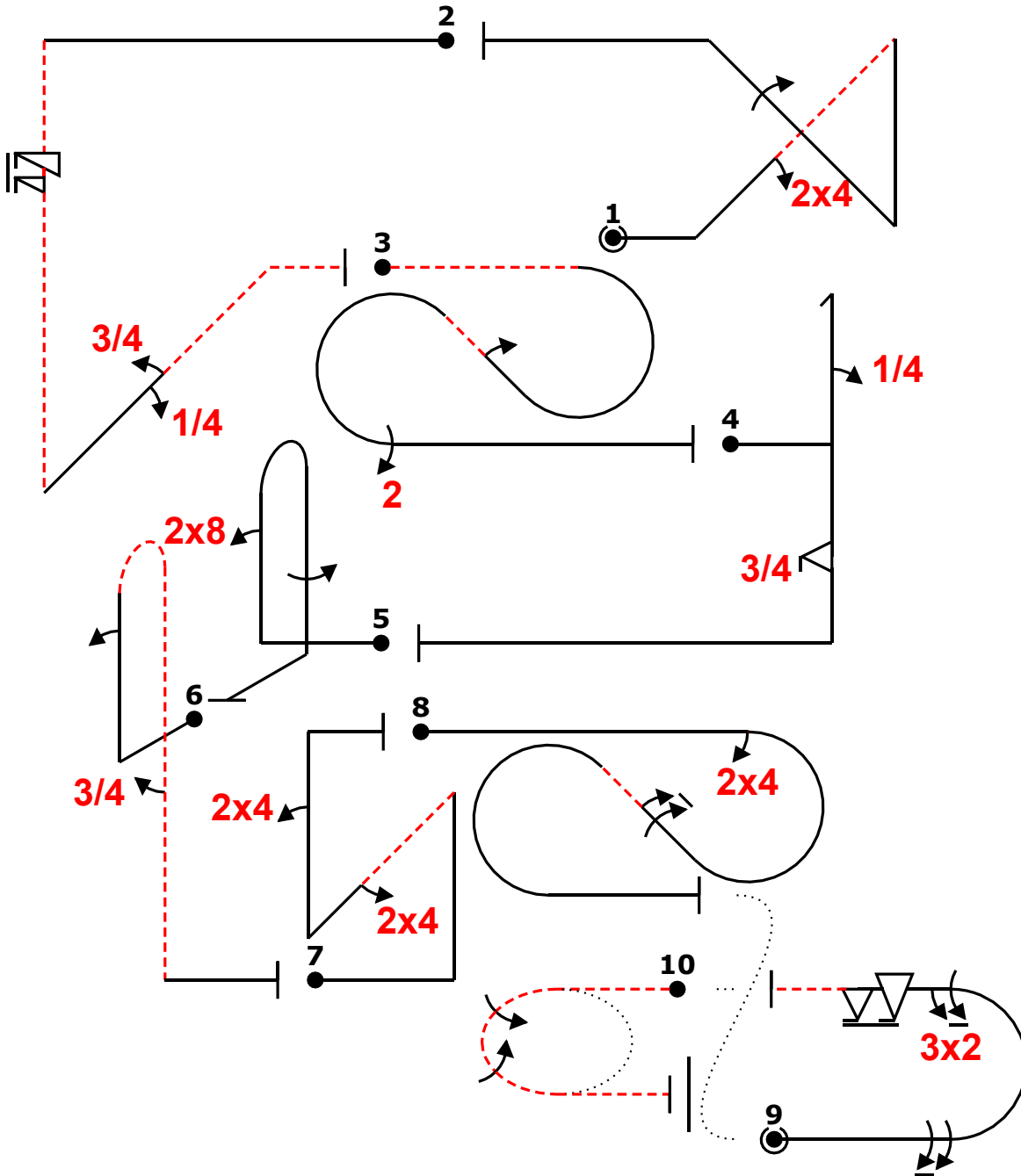
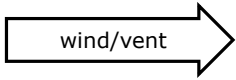

Power			
Fig	Aresti	K	
1 E	1.3.2.1	18	35
	9.4.2.2	7	
	9.1.2.4	10	
2 B	1.2.8.3	15	30
	9.11.1.6	3	
	9.1.2.1	4	
	9.1.2.3	8	
3	7.5.2.4	15	30
	9.1.2.2	6	
	9.2.3.4	9	
4 A	5.2.1.1	17	34
	9.1.1.1	6	
	9.9.5.3	11	
5	8.4.1.1	13	28
	9.8.1.1	7	
	9.1.5.4	8	
6 D	8.4.3.1	15	29
	9.1.1.2	8	
	9.1.5.3	6	
7	1.3.12.1	21	35
	9.4.4.2	5	
	9.4.1.2	9	
8 C	7.5.5.3	15	32
	9.4.3.2	5	
	9.1.2.6	12	
9	7.2.1.1	6	44
	9.1.3.8	12	
	9.2.3.6	12	
	9.9.3.6	14	
10	2.2.5.2	23	23
Total K = 320		(max K = 320)	

Salome GILLES Pilot
EXTRA 330 SC F-HLAf A/C

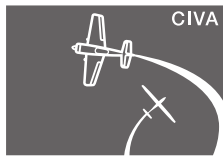

CIVA

FAI

AEROBATICS
COMMISSION

Form B

Pilot ID

CIVA Advanced Free Known

Flight #

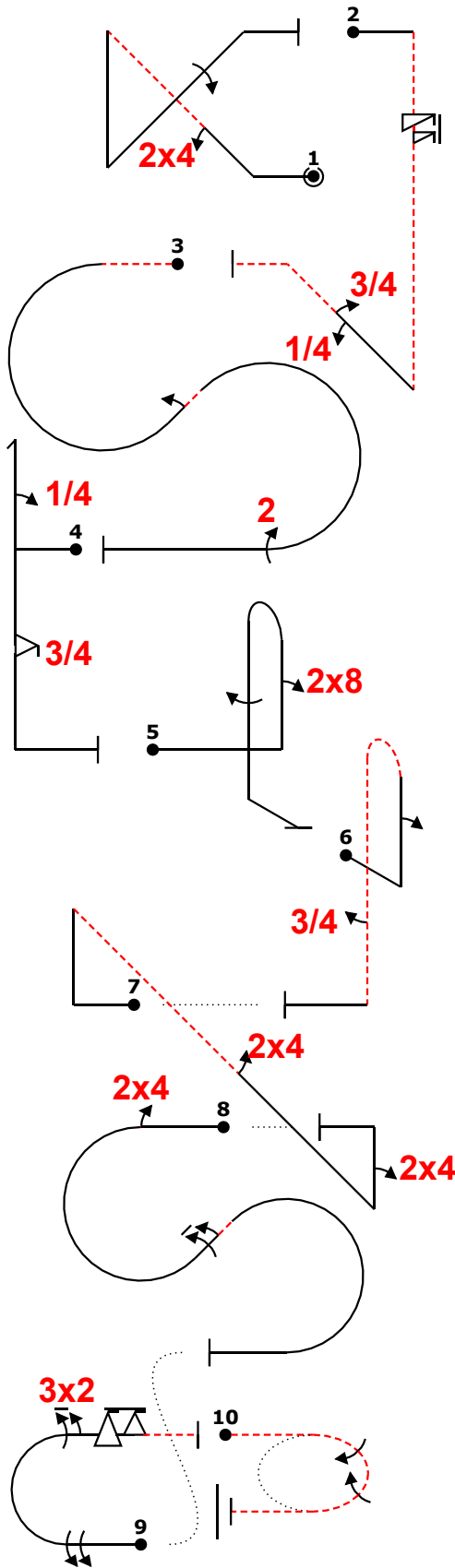
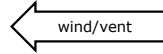

Power			
Fig	Aresti	K	
1 E	1.3.2.1	18	35
	9.4.2.2	7	
	9.1.2.4	10	
2 B	1.2.8.3	15	30
	9.11.1.6	3	
	9.1.2.1	4	
	9.1.2.3	8	
3	7.5.2.4	15	30
	9.1.2.2	6	
	9.2.3.4	9	
4 A	5.2.1.1	17	34
	9.1.1.1	6	
	9.9.5.3	11	
5	8.4.1.1	13	28
	9.8.1.1	7	
	9.1.5.4	8	
6 D	8.4.3.1	15	29
	9.1.1.2	8	
	9.1.5.3	6	
7	1.3.12.1	21	35
	9.4.4.2	5	
	9.4.1.2	9	
8 C	7.5.5.3	15	32
	9.4.3.2	5	
	9.1.2.6	12	
9	7.2.1.1	6	44
	9.1.3.8	12	
	9.2.3.6	12	
	9.9.3.6	14	
10	2.2.5.2	23	23
Total K = 320 (max K = 320)			

Tommy Douillard
Pilot
E330SC
A/C

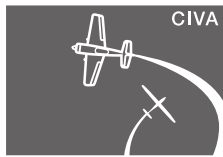

FAI

AEROBATICS
COMMISSION

Pilot ID

CIVA Advanced Free Known

Form C

Flight #

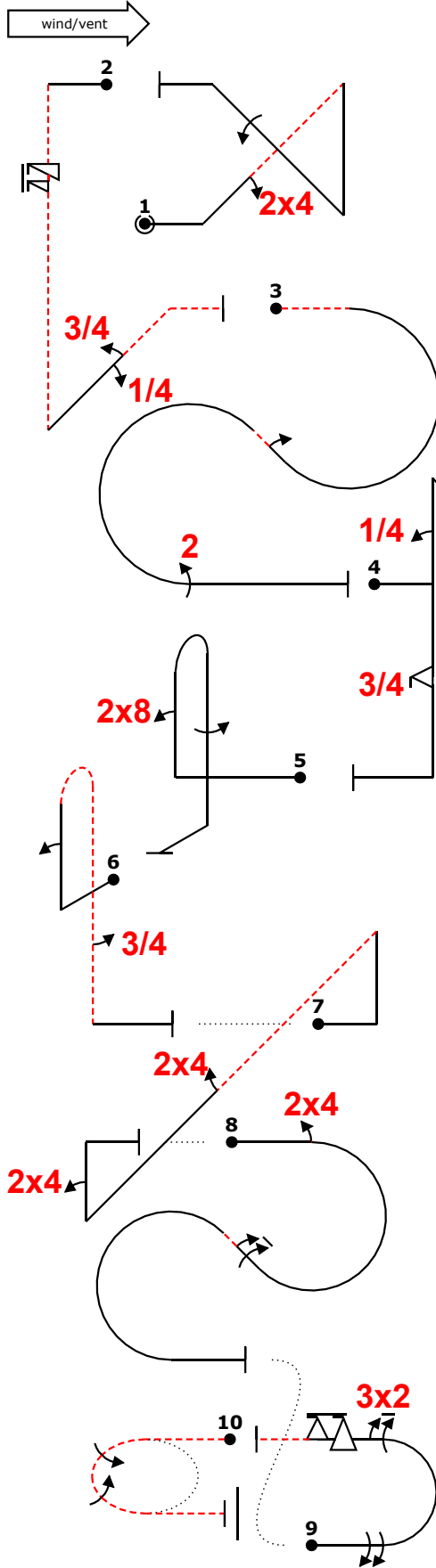

Power			
Fig	Aresti	K	
1 E	1.3.2.1	18	35
	9.4.2.2	7	
	9.1.2.4	10	
2 B	1.2.8.3	15	30
	9.11.1.6	3	
	9.1.2.1	4	
	9.1.2.3	8	
3	7.5.2.4	15	30
	9.1.2.2	6	
	9.2.3.4	9	
4 A	5.2.1.1	17	34
	9.1.1.1	6	
	9.9.5.3	11	
5	8.4.1.1	13	28
	9.8.1.1	7	
	9.1.5.4	8	
6 D	8.4.3.1	15	29
	9.1.1.2	8	
	9.1.5.3	6	
7	1.3.12.1	21	35
	9.4.4.2	5	
	9.4.1.2	9	
8 C	7.5.5.3	15	32
	9.4.3.2	5	
	9.1.2.6	12	
9	7.2.1.1	6	44
	9.1.3.8	12	
	9.2.3.6	12	
	9.9.3.6	14	
10	2.2.5.2	23	23
Total K = 320 (max K = 320)			

Tommy Douillard
E330SC
Pilot
A/C

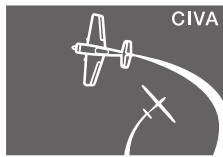

CIVA

FAI

AEROBATICS
COMMISSION

CF1 2020

Form B

Pilot ID

CIVA Advanced Programme1

Flight #

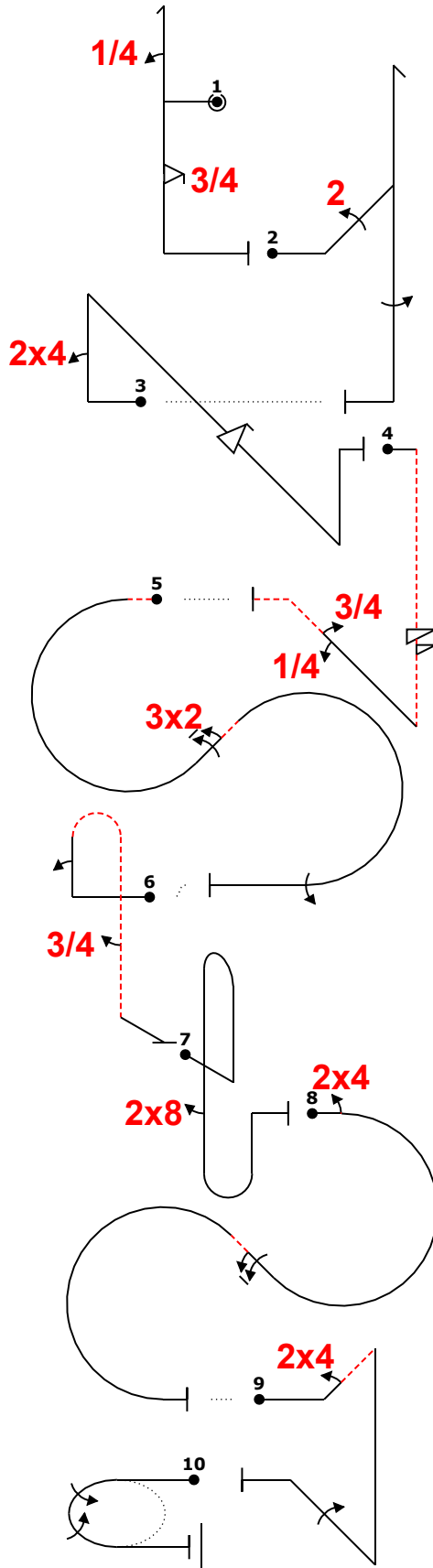
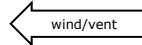

Power			
Fig	Aresti	K	
1 A	5.2.1.1	17	34
	9.1.1.1	6	
	9.9.5.3	11	
2	5.3.1.1	18	37
	9.2.2.4	11	
	9.1.5.4	8	
3	1.3.13.1	22	42
	9.4.1.2	9	
	9.9.4.4	11	
4 B	1.2.8.3	15	30
	9.11.1.6	3	
	9.1.2.1	4	
	9.1.2.3	8	
5	7.5.2.4	15	37
	9.2.2.6	14	
	9.1.3.4	8	
6 D	8.4.3.1	15	29
	9.1.1.2	8	
	9.1.5.3	6	
	9.1.2.3	6	
7	8.8.2.1	19	22
	9.8.5.1	3	
	9.8.5.1	3	
8 C	7.5.5.3	15	32
	9.4.3.2	5	
	9.1.2.6	12	
	9.1.2.6	12	
9 E	1.3.2.1	18	35
	9.4.2.2	7	
	9.1.2.4	10	
10	2.2.5.1	22	22
Total K = 320		(max K = 320)	

Graton Pilot
EX330SC F-HODV
A/C

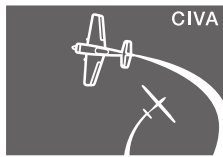

CIVA

FAI

AEROBATICS
COMMISSION

CF1 2020

Form C

Pilot ID

CIVA Advanced Programme1

Flight #

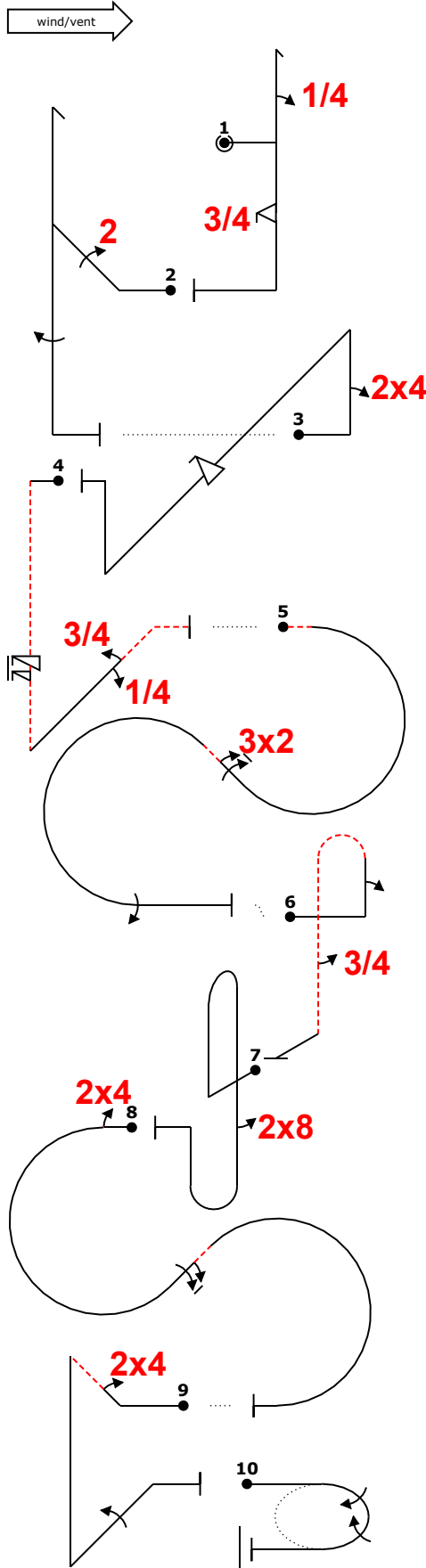

Power			
Fig	Aresti	K	
1 A	5.2.1.1	17	34
	9.1.1.1	6	
	9.9.5.3	11	
2	5.3.1.1	18	37
	9.2.2.4	11	
	9.1.5.4	8	
3	1.3.13.1	22	42
	9.4.1.2	9	
	9.9.4.4	11	
4 B	1.2.8.3	15	30
	9.11.1.6	3	
	9.1.2.1	4	
	9.1.2.3	8	
5	7.5.2.4	15	37
	9.2.2.6	14	
	9.1.3.4	8	
6 D	8.4.3.1	15	29
	9.1.1.2	8	
	9.1.5.3	6	
7	8.8.2.1	19	22
	9.8.5.1	3	
8 C	7.5.5.3	15	32
	9.4.3.2	5	
	9.1.2.6	12	
9 E	1.3.2.1	18	35
	9.4.2.2	7	
	9.1.2.4	10	
10	2.2.5.1	22	22
Total K = 320 (max K = 320)			

Graton Pilot
EX330SC F-HODV
A/C

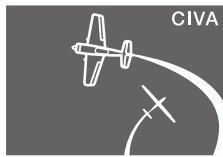

FAI

AEROBATICS
COMMISSION

Form B

Pilot ID

CIVA Advanced Programme1

Flight #

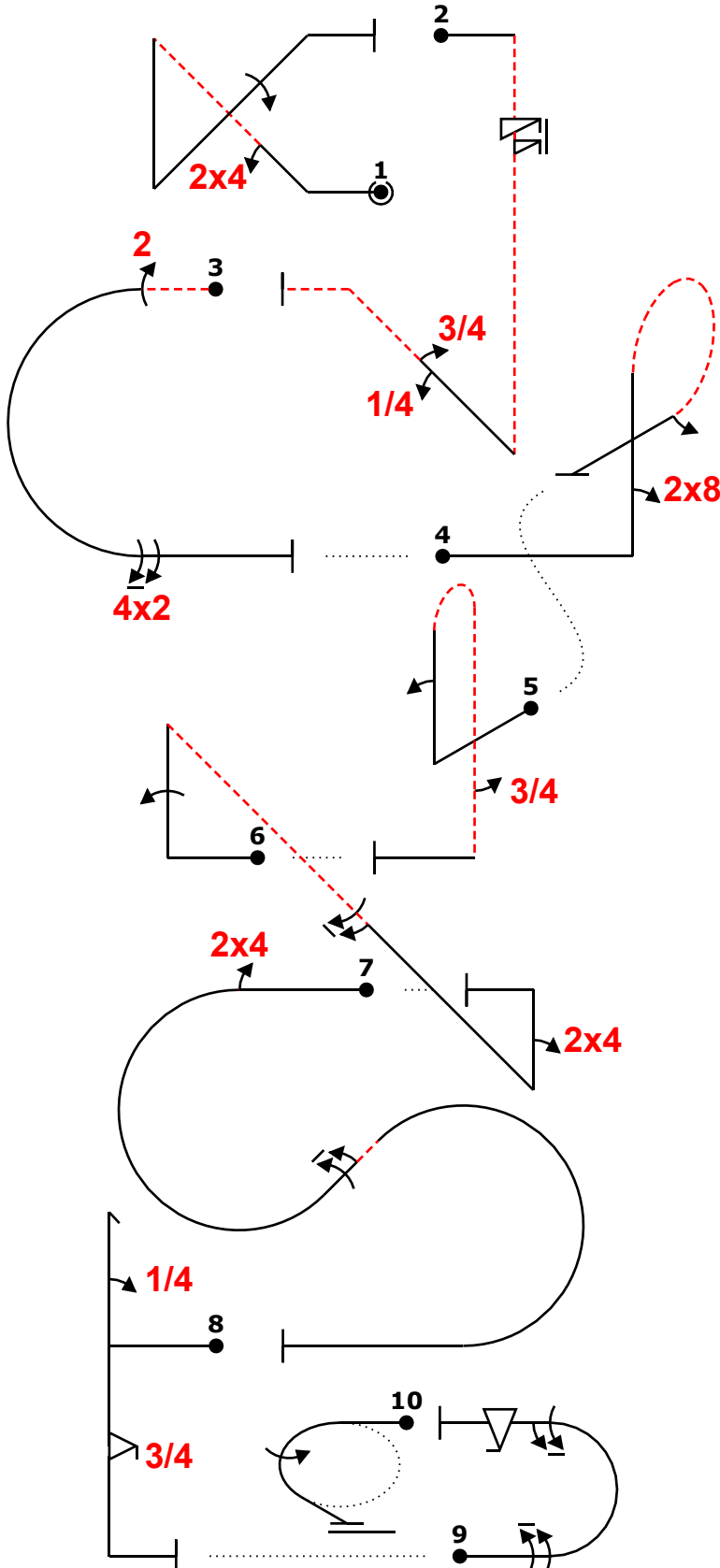
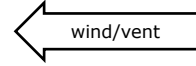

Power			
Fig	Aresti	K	
1 E	1.3.2.1	18	35
	9.4.2.2	7	
	9.1.2.4	10	
2 B	1.2.8.3	15	30
	9.11.1.6	3	
	9.1.2.1	4	
3	9.1.2.3	8	30
	7.2.1.4	6	
	9.2.3.4	9	
4	9.2.3.8	15	25
	8.6.4.1	14	
	9.8.1.1	7	
5 D	9.1.3.2	4	29
	8.4.3.1	15	
	9.1.1.2	8	
6	9.1.5.3	6	52
	1.3.12.1	21	
	9.1.1.4	12	
7 C	9.1.4.6	10	32
	9.4.1.2	9	
	7.5.5.3	15	
8 A	9.4.3.2	5	34
	9.1.2.6	12	
	5.2.1.1	17	
9	9.1.1.1	6	39
	9.9.5.3	11	
	7.2.2.1	6	
	9.1.3.8	12	
10	9.1.3.6	10	14
	9.9.3.4	11	
	2.1.3.1	14	
Total K = 320 (max K = 320)			

Pilot
A/C

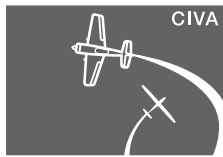

FAI

AEROBATICS
COMMISSION

Pilot ID

CIVA Advanced Programme1

Form C

Flight #

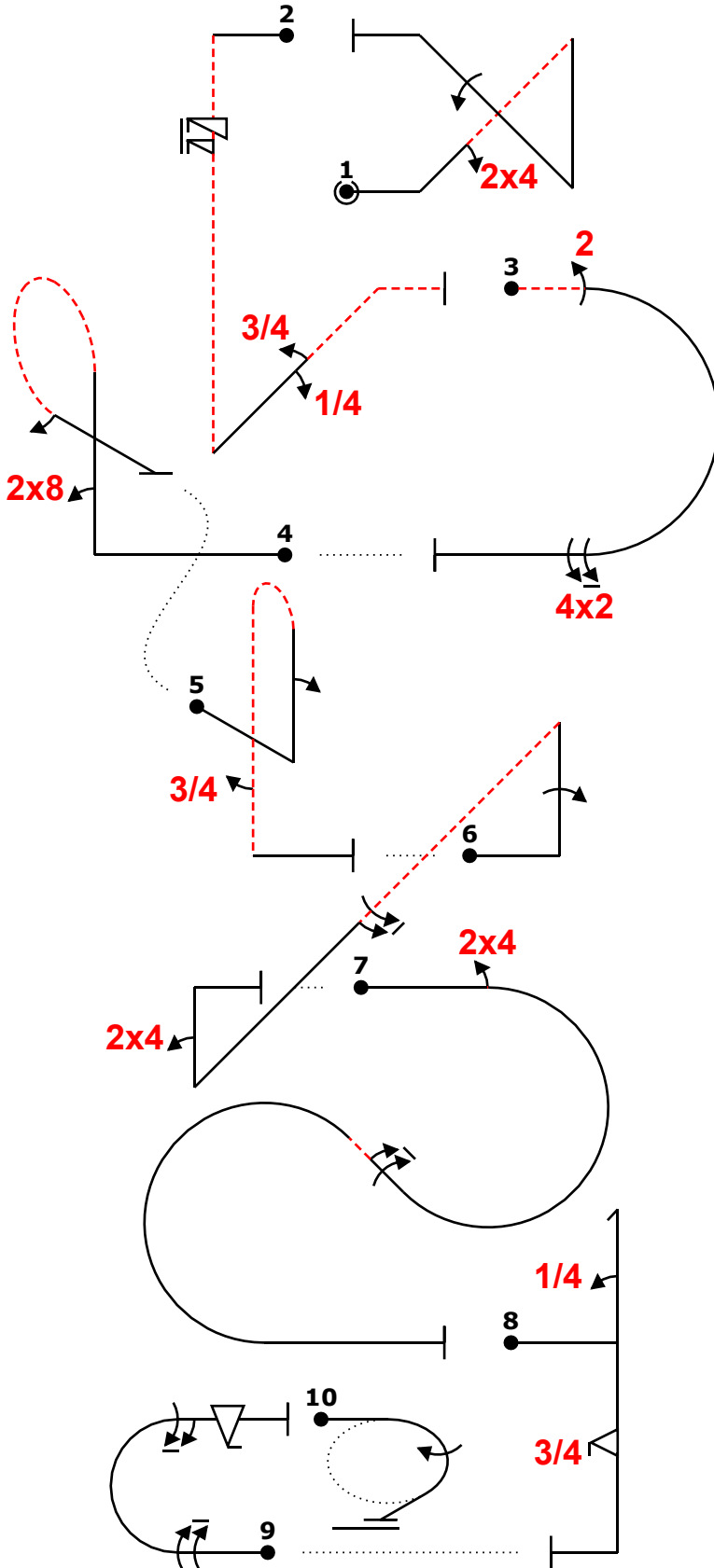
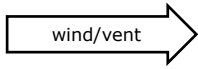

Power			
Fig	Aresti	K	
1 E	1.3.2.1	18	35
	9.4.2.2	7	
	9.1.2.4	10	
2 B	1.2.8.3	15	30
	9.11.1.6	3	
	9.1.2.1	4	
	9.1.2.3	8	
3	7.2.1.4	6	30
	9.2.3.4	9	
	9.2.3.8	15	
4	8.6.4.1	14	25
	9.8.1.1	7	
	9.1.3.2	4	
5 D	8.4.3.1	15	29
	9.1.1.2	8	
	9.1.5.3	6	
6	1.3.12.1	21	52
	9.1.1.4	12	
	9.1.4.6	10	
	9.4.1.2	9	
7 C	7.5.5.3	15	32
	9.4.3.2	5	
	9.1.2.6	12	
8 A	5.2.1.1	17	34
	9.1.1.1	6	
	9.9.5.3	11	
9	7.2.2.1	6	39
	9.1.3.8	12	
	9.1.3.6	10	
	9.9.3.4	11	
10	2.1.3.1	14	14
Total K = 320		(max K = 320)	

 Pilot
 A/C

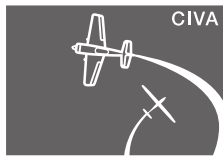

CIVA

FAI

AEROBATICS
COMMISSION

Pilot ID

CIVA Advanced Free Known

Form B

Flight #

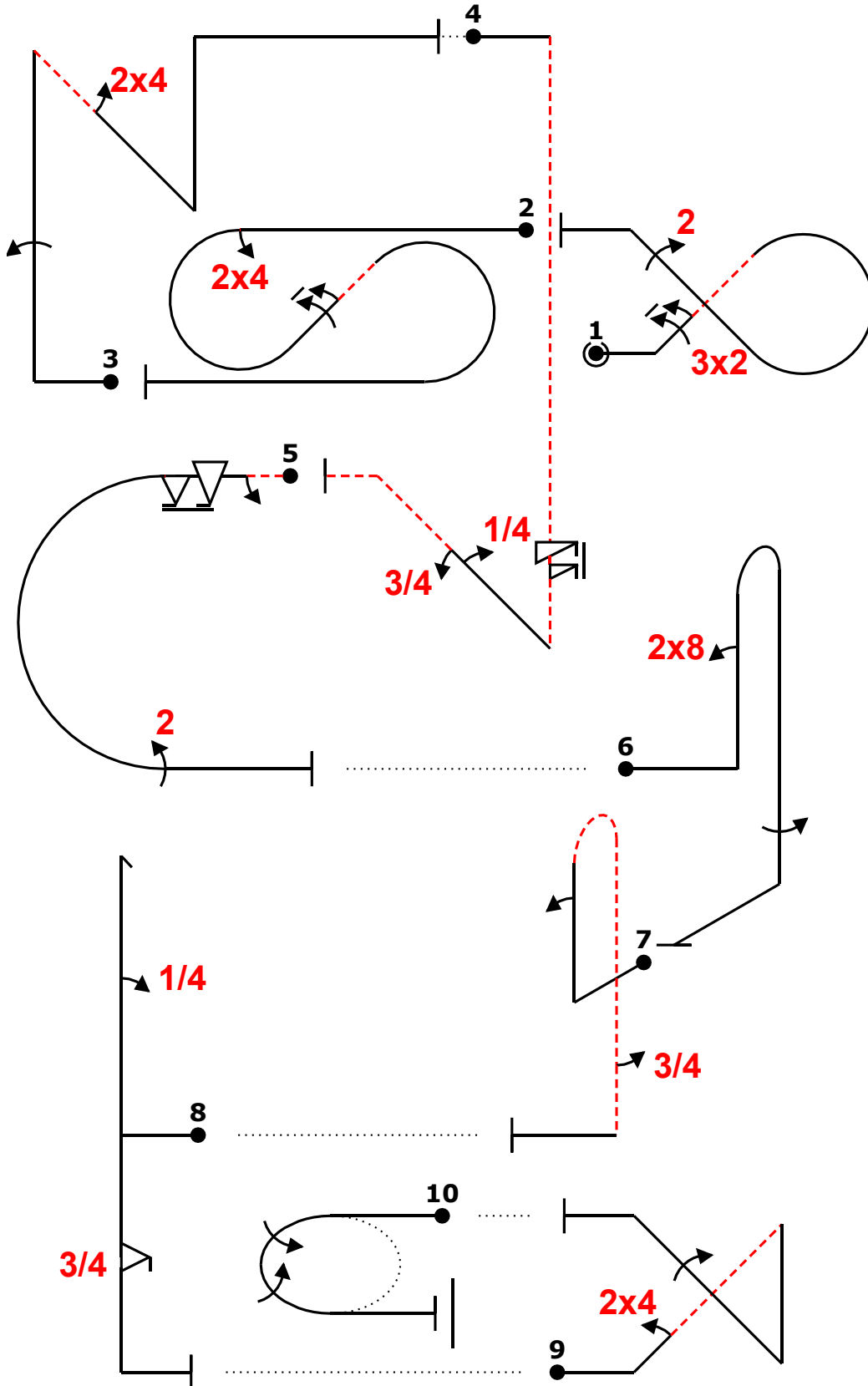
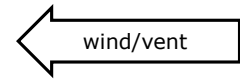

Power			
Fig	Aresti	K	
1	7.3.2.1	14	39
	9.2.2.6	14	
	9.2.2.4	11	
2 C	7.5.5.3	15	32
	9.4.3.2	5	
	9.1.2.6	12	
3	1.3.12.1	21	38
	9.1.1.4	12	
	9.4.4.2	5	
4 B	1.2.8.3	15	30
	9.11.1.6	3	
	9.1.2.1	4	
	9.1.2.3	8	
5	7.2.1.4	6	33
	9.1.3.2	4	
	9.9.3.6	14	
	9.2.3.4	9	
6	8.4.1.1	13	28
	9.8.1.1	7	
	9.1.5.4	8	
7 D	8.4.3.1	15	29
	9.1.1.2	8	
	9.1.5.3	6	
8 A	5.2.1.1	17	34
	9.1.1.1	6	
	9.9.5.3	11	
9 E	1.3.2.1	18	35
	9.4.2.2	7	
	9.1.2.4	10	
10	2.2.5.1	22	22
Total K = 320 (max K = 320)			

Jeremy Renard Pilot
CAP32SC F-HERA A/C

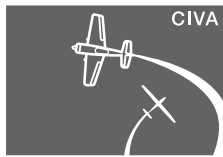

FAI

AEROBATICS
COMMISSION

Pilot ID

CIVA Advanced Free Known

Form C

Flight #

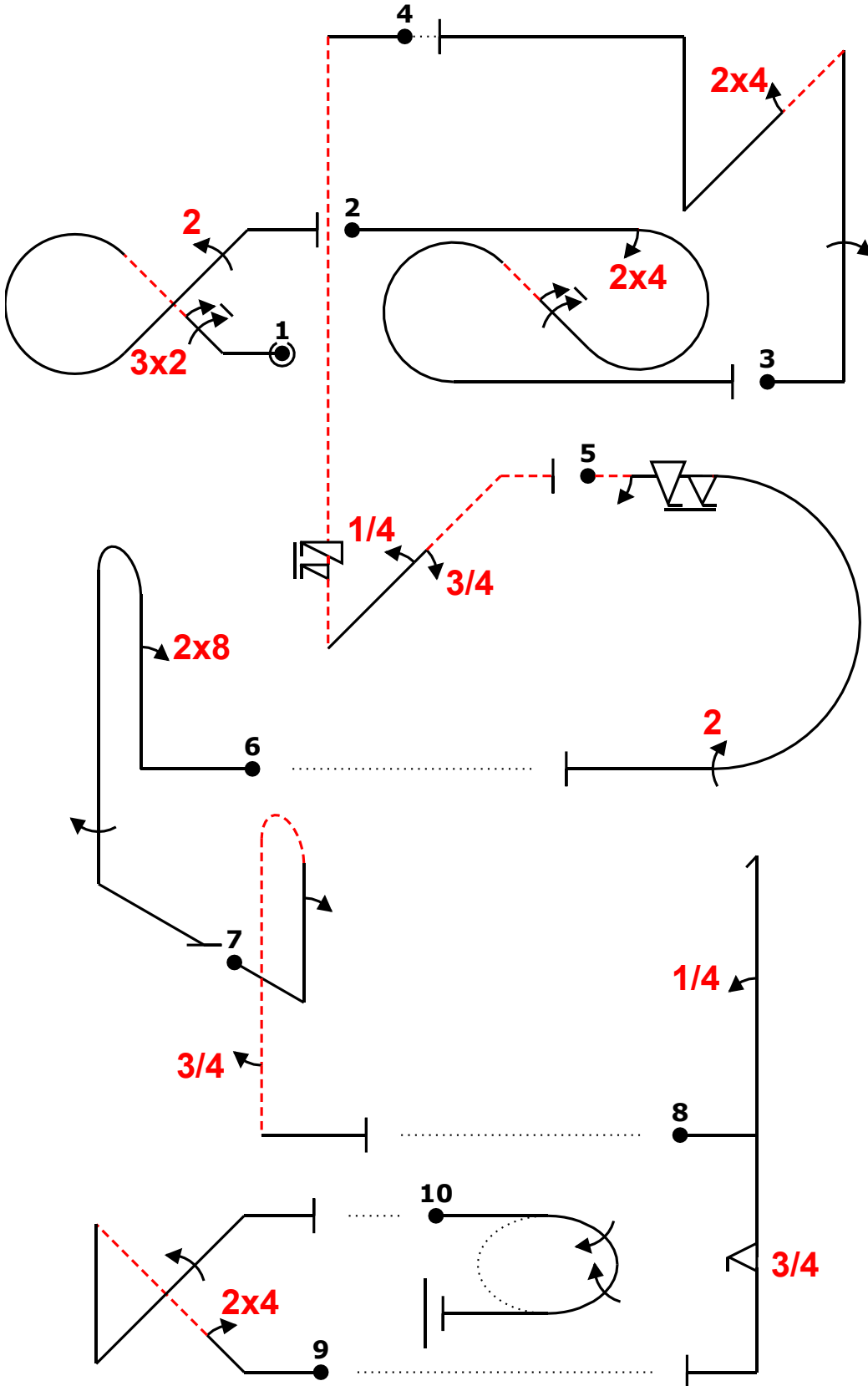
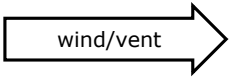

Power			
Fig	Aresti	K	
1	7.3.2.1	14	39
	9.2.2.6	14	
	9.2.2.4	11	
2 C	7.5.5.3	15	32
	9.4.3.2	5	
	9.1.2.6	12	
3	1.3.12.1	21	38
	9.1.1.4	12	
	9.4.4.2	5	
4 B	1.2.8.3	15	30
	9.11.1.6	3	
	9.1.2.1	4	
	9.1.2.3	8	
5	7.2.1.4	6	33
	9.1.3.2	4	
	9.9.3.6	14	
	9.2.3.4	9	
6	8.4.1.1	13	28
	9.8.1.1	7	
	9.1.5.4	8	
7 D	8.4.3.1	15	29
	9.1.1.2	8	
	9.1.5.3	6	
8 A	5.2.1.1	17	34
	9.1.1.1	6	
	9.9.5.3	11	
9 E	1.3.2.1	18	35
	9.4.2.2	7	
	9.1.2.4	10	
10	2.2.5.1	22	22
Total K = 320		(max K = 320)	

Jeremy Renard Pilot
CAP32SC F-HERA
A/C

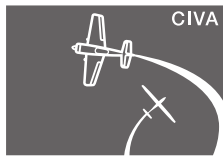

CIVA

FAI

AEROBATICS
COMMISSION

Form B

Pilot ID

CIVA Advanced Programme1

Flight #

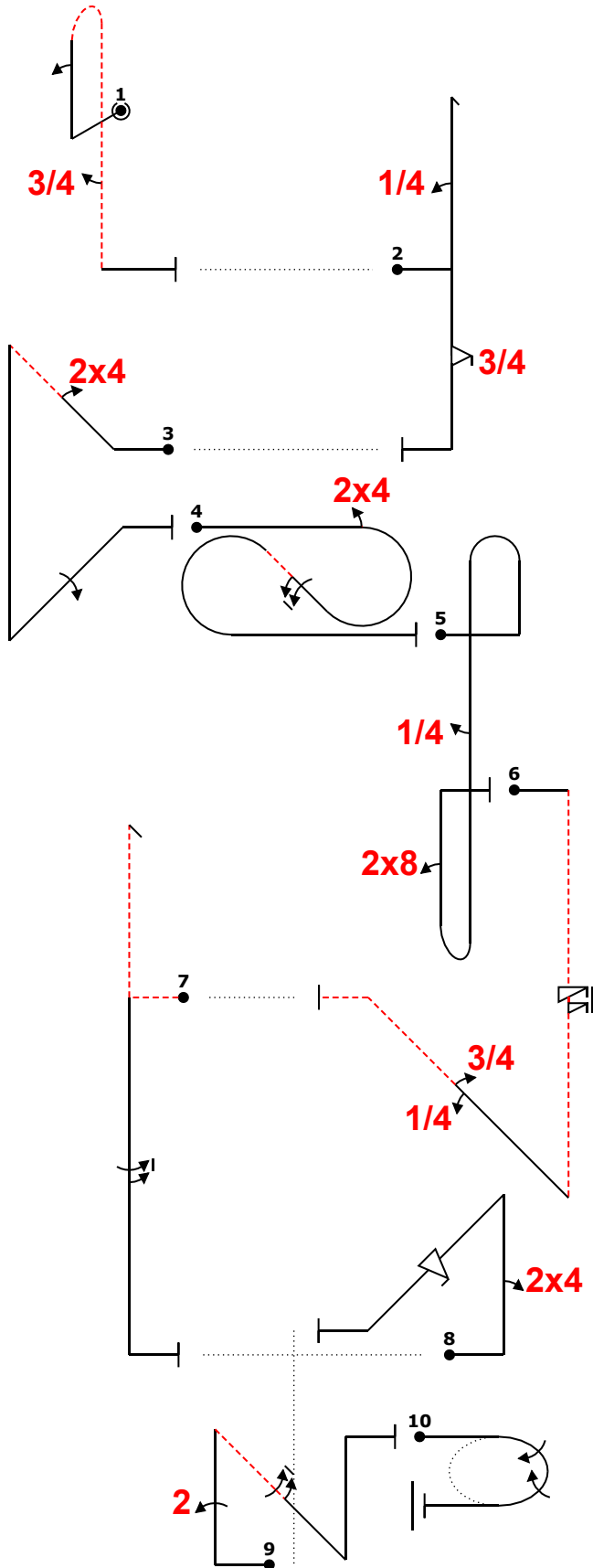
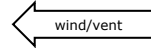

Power			
Fig	Aresti	K	
1 D	8.4.3.1	15	29
	9.1.1.2	8	
	9.1.5.3	6	
2 A	5.2.1.1	17	34
	9.1.1.1	6	
	9.9.5.3	11	
3 E	1.3.2.1	18	35
	9.4.2.2	7	
	9.1.2.4	10	
4 C	7.5.5.3	15	32
	9.4.3.2	5	
	9.1.2.6	12	
5	8.8.2.1	19	28
	9.1.5.1	2	
	9.8.1.1	7	
6 B	1.2.8.3	15	30
	9.11.1.6	3	
	9.1.2.1	4	
	9.1.2.3	8	
7	5.2.1.4	22	32
	9.1.5.6	10	
8	1.2.6.1	14	34
	9.4.1.2	9	
	9.9.4.4	11	
9	1.3.12.1	21	44
	9.2.1.4	13	
	9.1.4.6	10	
10	2.2.5.1	22	22
Total K = 320			
(max K = 320)			

Matthieu Vaillant
Pilot
ARS300 FPDCF
A/C

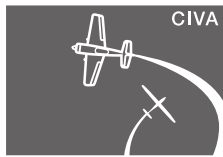

CIVA

FAI

AEROBATICS
COMMISSION

Pilot ID

CIVA Advanced Programme1

Form C

Flight #

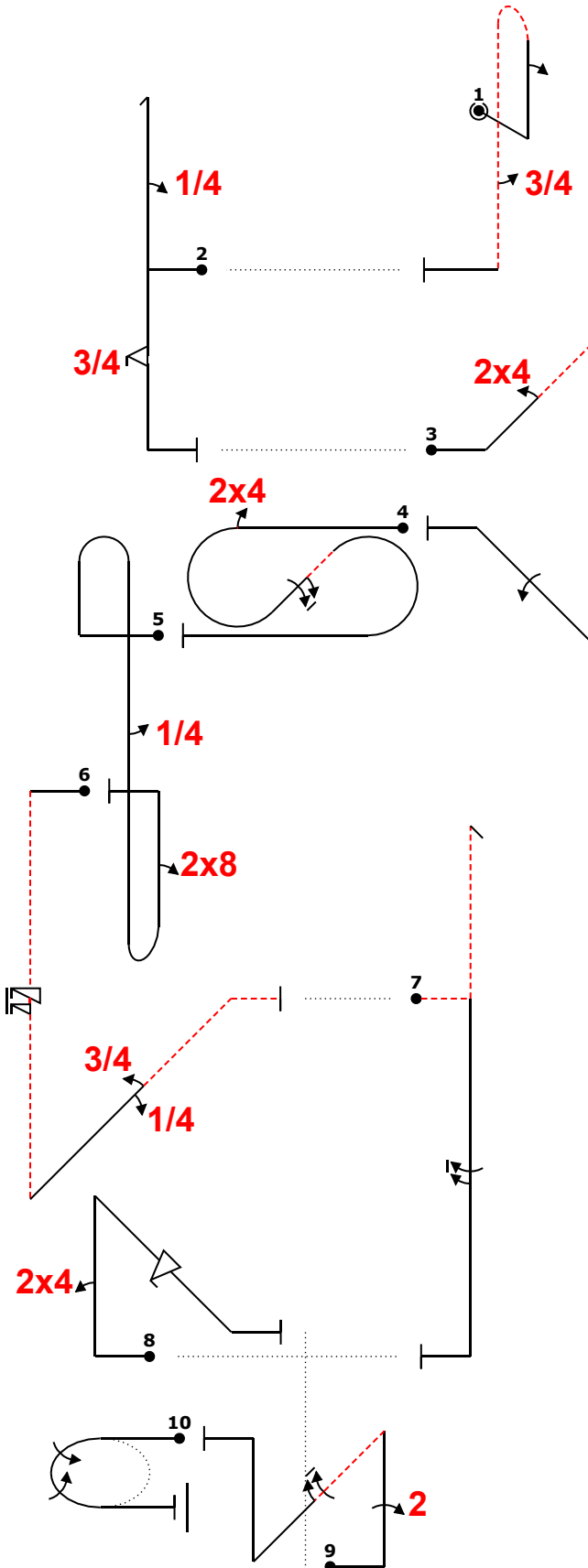

Power			
Fig	Aresti	K	
1 D	8.4.3.1	15	29
	9.1.1.2	8	
	9.1.5.3	6	
2 A	5.2.1.1	17	34
	9.1.1.1	6	
	9.9.5.3	11	
3 E	1.3.2.1	18	35
	9.4.2.2	7	
	9.1.2.4	10	
4 C	7.5.5.3	15	32
	9.4.3.2	5	
	9.1.2.6	12	
5	8.8.2.1	19	28
	9.1.5.1	2	
	9.8.1.1	7	
6 B	1.2.8.3	15	30
	9.11.1.6	3	
	9.1.2.1	4	
	9.1.2.3	8	
7	5.2.1.4	22	32
	9.1.5.6	10	
8	1.2.6.1	14	34
	9.4.1.2	9	
	9.9.4.4	11	
9	1.3.12.1	21	44
	9.2.1.4	13	
	9.1.4.6	10	
10	2.2.5.1	22	22
Total K = 320		(max K = 320)	

Matthieu Vaillant
Pilot
ARS300 FPDCF
A/C

Pilot ID		France Advanced connu-libre	Form B
			Flight #

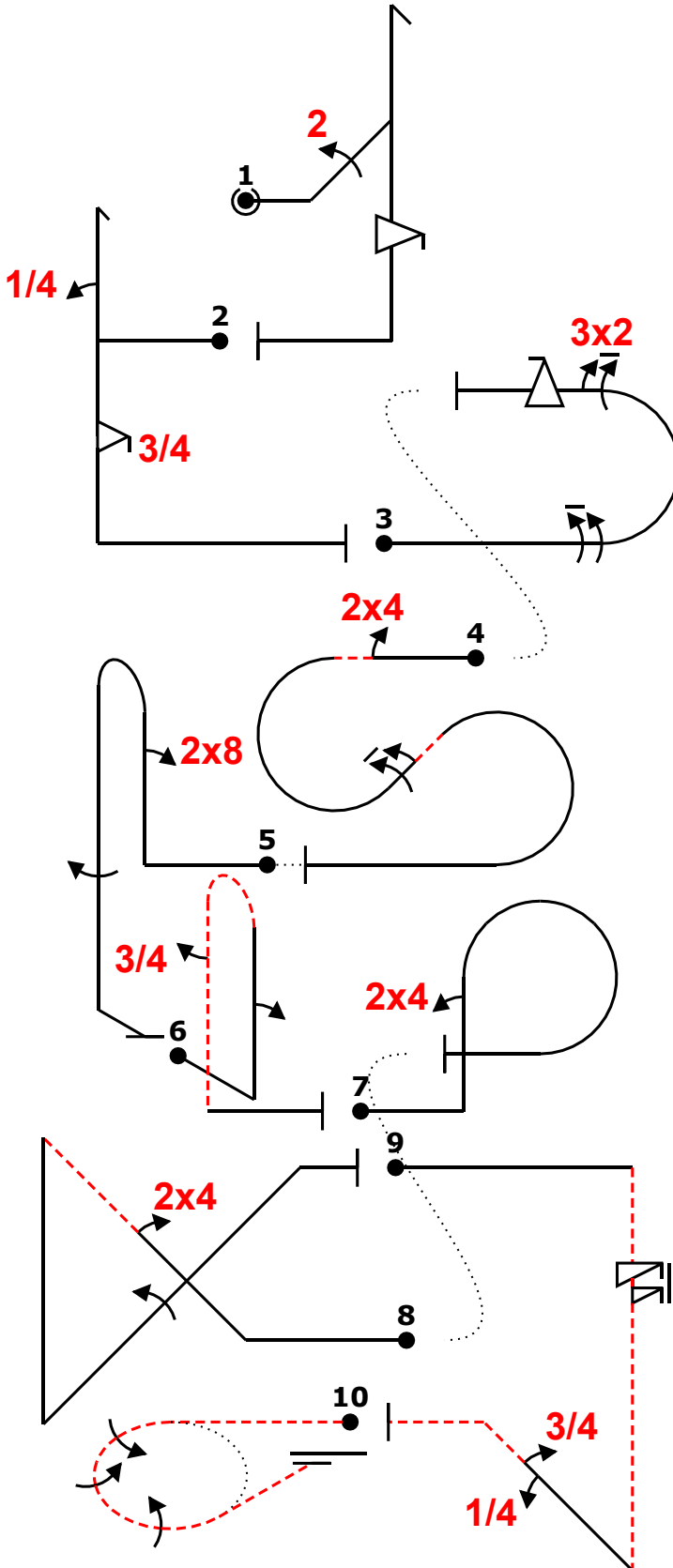
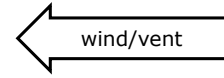

Power			
Fig	Aresti	K	
1	5.3.1.1	18	40
	9.2.2.4	11	
	9.9.5.4	11	
2 A	5.2.1.1	17	34
	9.1.1.1	6	
	9.9.5.3	11	
3	7.2.2.1	6	41
	9.1.3.8	12	
	9.2.3.6	12	
	9.9.3.4	11	
4 C	7.5.5.3	15	32
	9.4.3.2	5	
	9.1.2.6	12	
5	8.4.1.1	13	28
	9.8.1.1	7	
	9.1.5.4	8	
6 D	8.4.3.1	15	29
	9.1.1.2	8	
	9.1.5.3	6	
7	8.6.1.1	11	20
	9.4.1.2	9	
8 E	1.3.2.1	18	35
	9.4.2.2	7	
	9.1.2.4	10	
9 B	1.2.8.3	15	30
	9.11.1.6	3	
	9.1.2.1	4	
	9.1.2.3	8	
10	2.3.4.2	31	31
Total K = 320 (max K = 320)			

		Form C
Pilot ID	France Advanced connu-libre	
	Flight #	

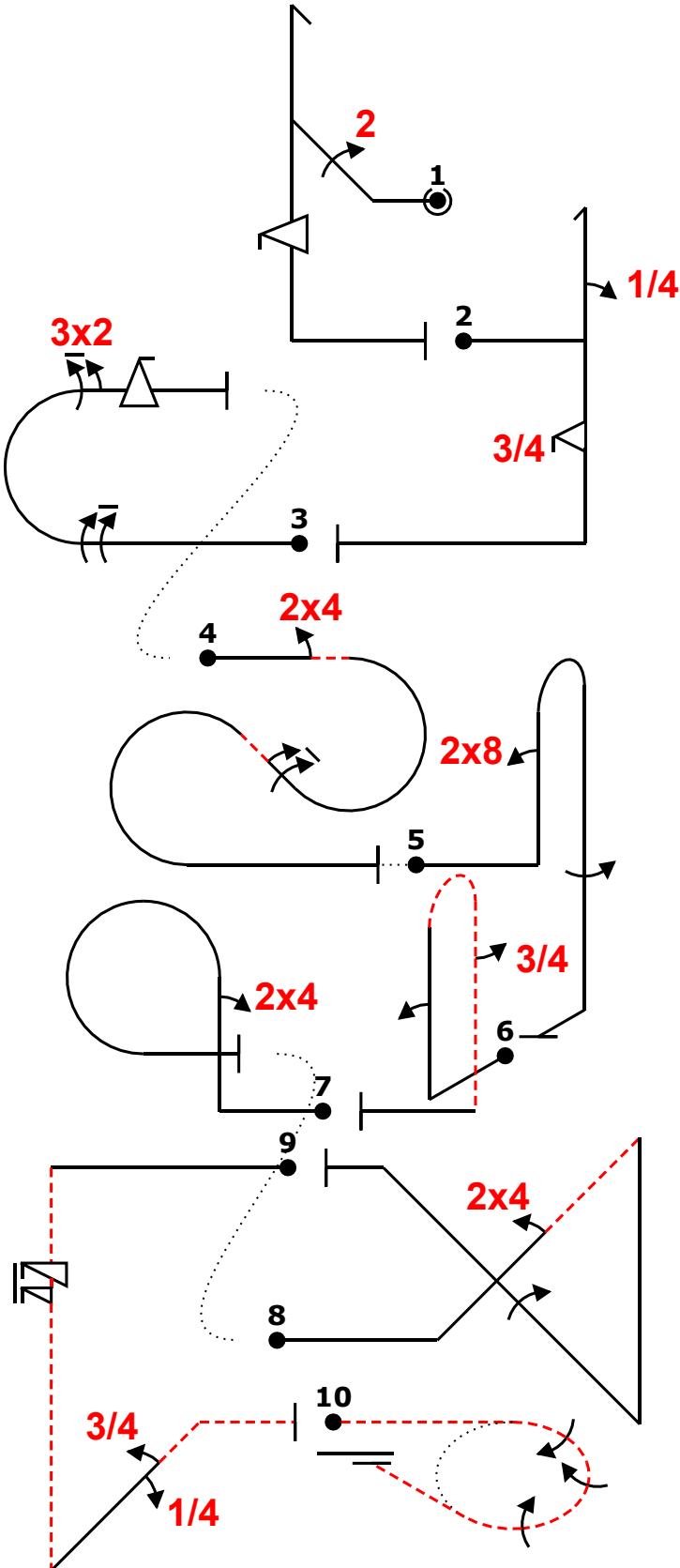
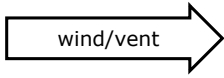

Power			
Fig	Aresti	K	
1	5.3.1.1	18	40
	9.2.2.4	11	
	9.9.5.4	11	
2 A	5.2.1.1	17	34
	9.1.1.1	6	
	9.9.5.3	11	
3	7.2.2.1	6	41
	9.1.3.8	12	
	9.2.3.6	12	
	9.9.3.4	11	
4 C	7.5.5.3	15	32
	9.4.3.2	5	
	9.1.2.6	12	
5	8.4.1.1	13	28
	9.8.1.1	7	
	9.1.5.4	8	
6 D	8.4.3.1	15	29
	9.1.1.2	8	
	9.1.5.3	6	
7	8.6.1.1	11	20
	9.4.1.2	9	
8 E	1.3.2.1	18	35
	9.4.2.2	7	
	9.1.2.4	10	
9 B	1.2.8.3	15	30
	9.11.1.6	3	
	9.1.2.1	4	
	9.1.2.3	8	
10	2.3.4.2	31	31
Total K = 320 (max K = 320)			

		Form B
Pilot ID	France Advanced connu-libre	
	Flight #	

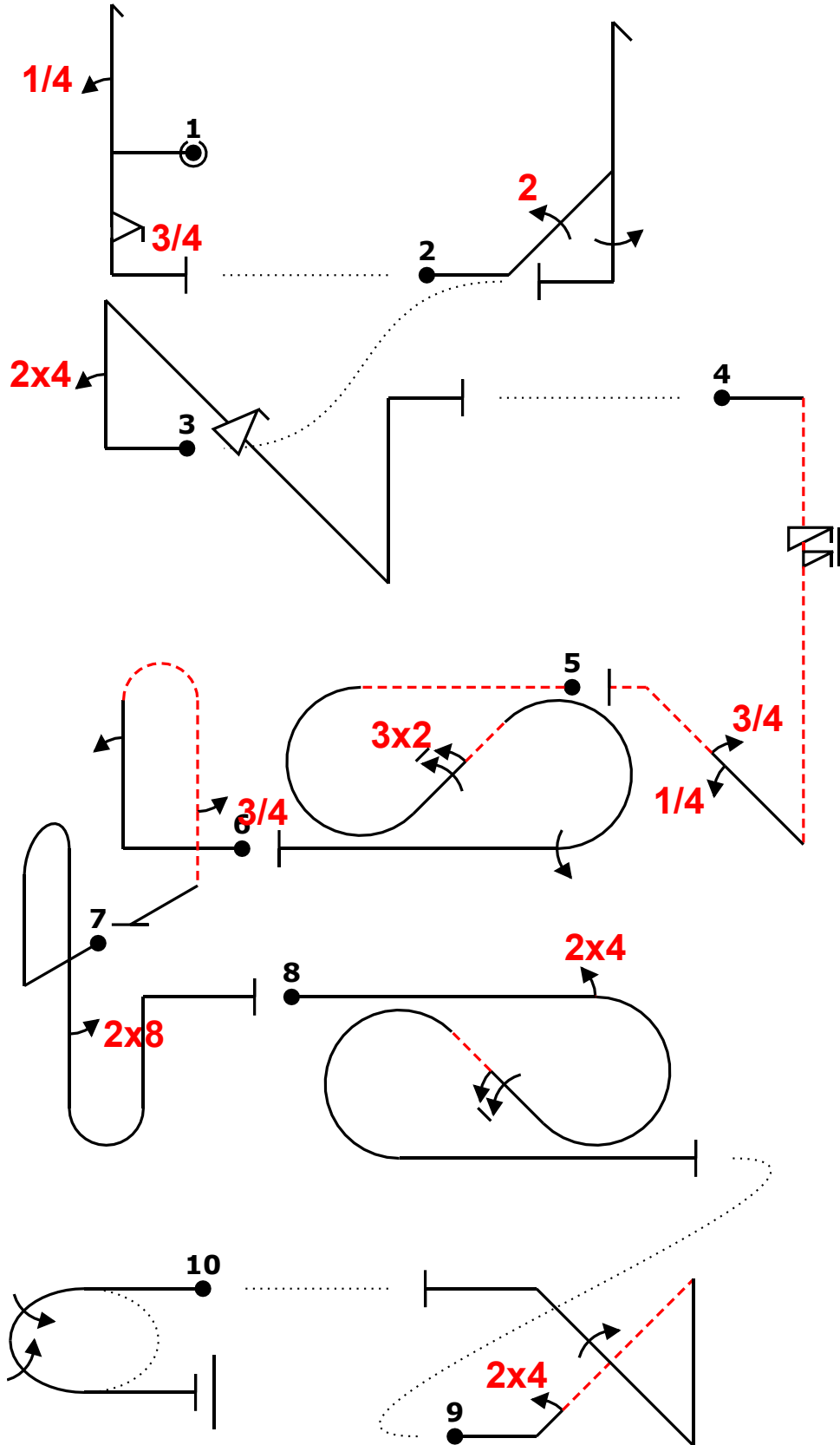
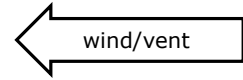

Power			
Fig	Aresti	K	
1 A	5.2.1.1	17	34
	9.1.1.1	6	
	9.9.5.3	11	
2	5.3.1.1	18	37
	9.2.2.4	11	
	9.1.5.4	8	
3	1.3.13.1	22	42
	9.4.1.2	9	
	9.9.4.4	11	
4 B	1.2.8.3	15	30
	9.11.1.6	3	
	9.1.2.1	4	
	9.1.2.3	8	
5	7.5.2.4	15	37
	9.2.2.6	14	
	9.1.3.4	8	
6 D	8.4.3.1	15	29
	9.1.1.2	8	
	9.1.5.3	6	
7	8.8.2.1	19	22
	9.8.5.1	3	
8 C	7.5.5.3	15	32
	9.4.3.2	5	
	9.1.2.6	12	
9 E	1.3.2.1	18	35
	9.4.2.2	7	
	9.1.2.4	10	
10	2.2.5.1	22	22
Total K = 320 (max K = 320)			

Marcille Pilot
A/C

		Form C
Pilot ID	France Advanced connu-libre	
	Flight #	

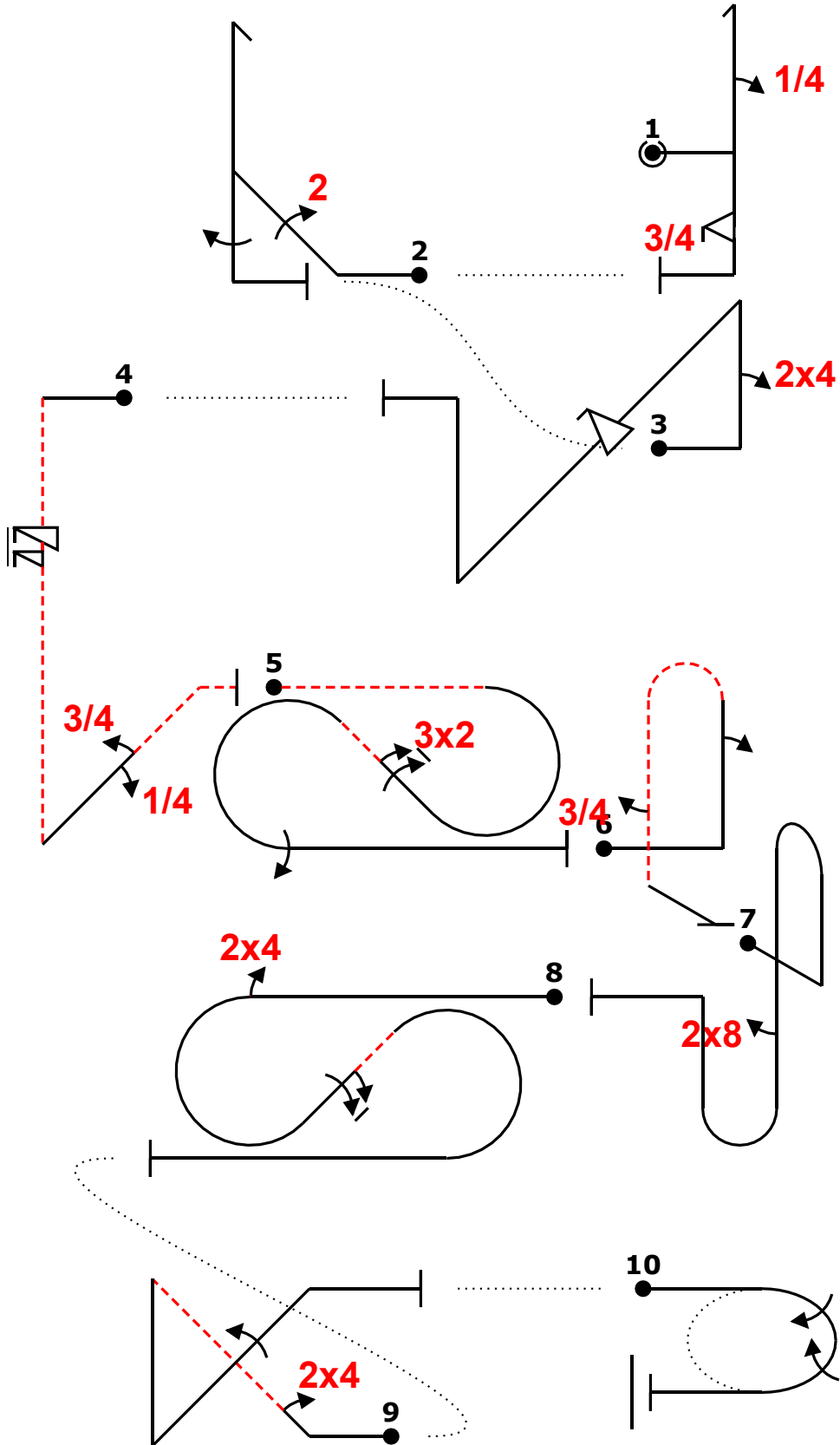
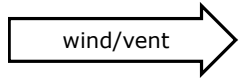

Power			
Fig	Aresti	K	
1 A	5.2.1.1	17	34
	9.1.1.1	6	
	9.9.5.3	11	
2	5.3.1.1	18	37
	9.2.2.4	11	
	9.1.5.4	8	
3	1.3.13.1	22	42
	9.4.1.2	9	
	9.9.4.4	11	
4 B	1.2.8.3	15	30
	9.11.1.6	3	
	9.1.2.1	4	
	9.1.2.3	8	
5	7.5.2.4	15	37
	9.2.2.6	14	
	9.1.3.4	8	
6 D	8.4.3.1	15	29
	9.1.1.2	8	
	9.1.5.3	6	
7	8.8.2.1	19	22
	9.8.5.1	3	
8 C	7.5.5.3	15	32
	9.4.3.2	5	
	9.1.2.6	12	
9 E	1.3.2.1	18	35
	9.4.2.2	7	
	9.1.2.4	10	
10	2.2.5.1	22	22
Total K = 320		(max K = 320)	

Marcille Pilot
A/C

		Form B
Pilot ID	France Advanced connu-libre	Flight #

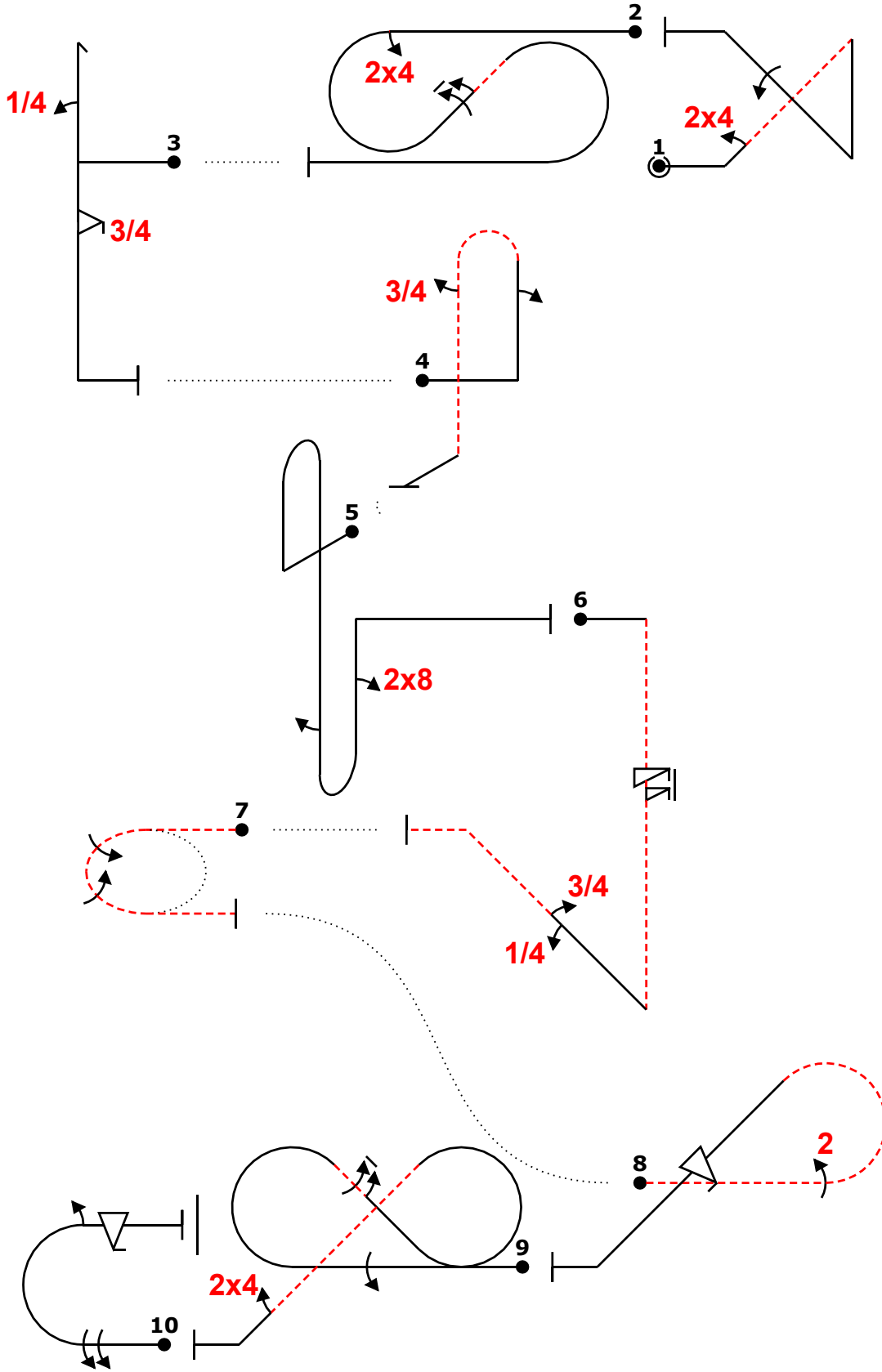
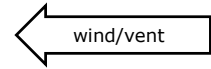

Power			
Fig	Aresti	K	
1 E	1.3.2.1	18	35
	9.4.2.2	7	
	9.1.2.4	10	
2 C	7.5.5.3	15	32
	9.4.3.2	5	
	9.1.2.6	12	
3 A	5.2.1.1	17	34
	9.1.1.1	6	
	9.9.5.3	11	
4 D	8.4.3.1	15	29
	9.1.1.2	8	
	9.1.5.3	6	
5	8.8.2.1	19	30
	9.1.5.2	4	
	9.8.1.1	7	
6 B	1.2.8.3	15	30
	9.11.1.6	3	
	9.1.2.1	4	
	9.1.2.3	8	
7	2.2.5.2	23	23
8	8.5.5.2	12	32
	9.2.3.4	9	
	9.9.4.4	11	
9	7.8.4.1	19	42
	9.1.3.4	8	
	9.1.4.6	10	
	9.4.4.2	5	
10	7.2.2.1	6	33
	9.1.3.8	12	
	9.1.3.2	4	
	9.9.3.4	11	
Total K = 320		(max K = 320)	

		Form C
Pilot ID	France Advanced connu-libre	
	Flight #	

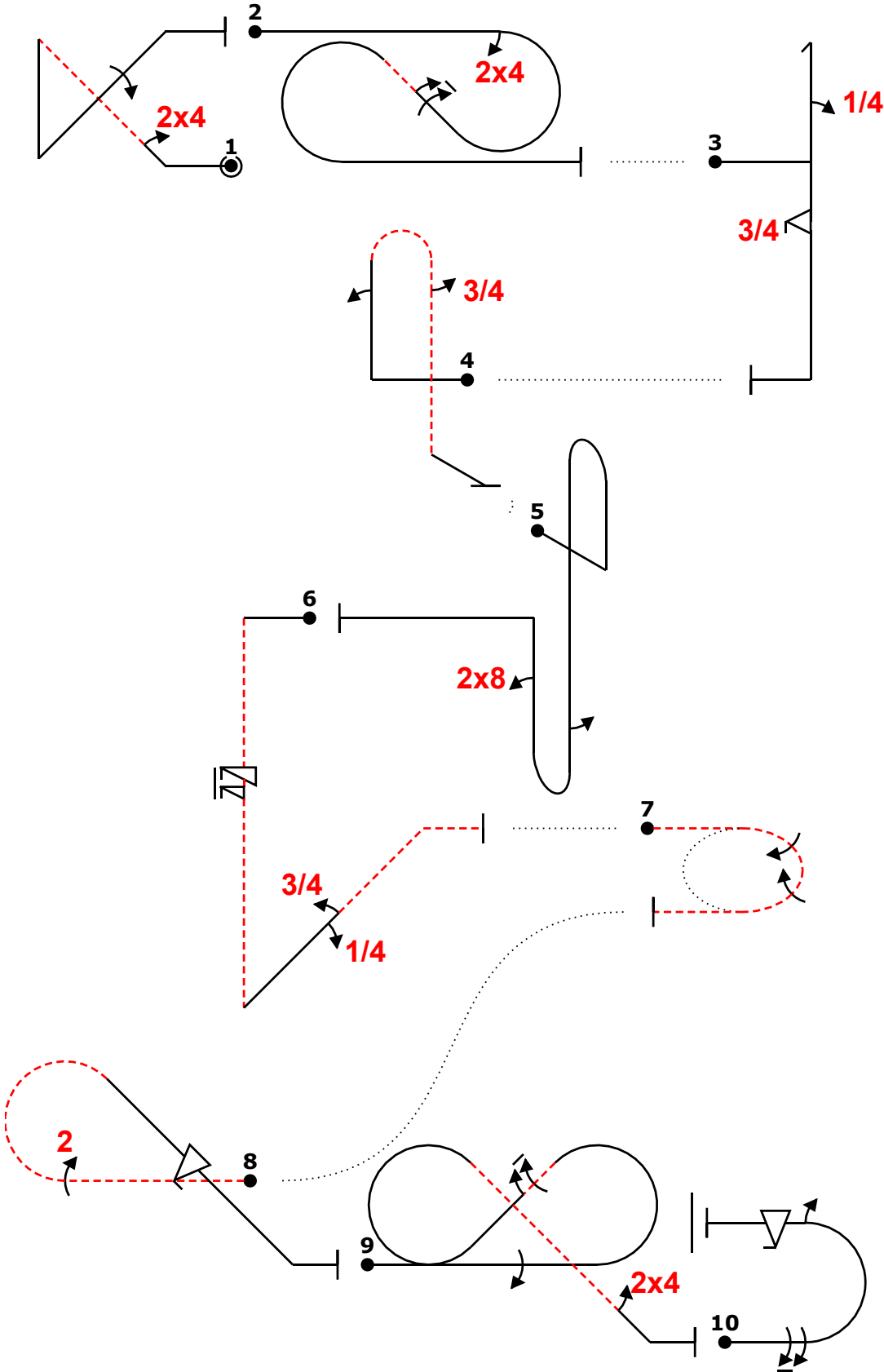
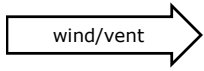

Power			
Fig	Aresti	K	
1 E	1.3.2.1	18	35
	9.4.2.2	7	
	9.1.2.4	10	
2 C	7.5.5.3	15	32
	9.4.3.2	5	
	9.1.2.6	12	
3 A	5.2.1.1	17	34
	9.1.1.1	6	
	9.9.5.3	11	
4 D	8.4.3.1	15	29
	9.1.1.2	8	
	9.1.5.3	6	
5	8.8.2.1	19	30
	9.1.5.2	4	
	9.8.1.1	7	
6 B	1.2.8.3	15	30
	9.11.1.6	3	
	9.1.2.1	4	
	9.1.2.3	8	
7	2.2.5.2	23	23
8	8.5.5.2	12	32
	9.2.3.4	9	
	9.9.4.4	11	
9	7.8.4.1	19	42
	9.1.3.4	8	
	9.1.4.6	10	
	9.4.4.2	5	
10	7.2.2.1	6	33
	9.1.3.8	12	
	9.1.3.2	4	
	9.9.3.4	11	
Total K = 320 (max K = 320)			

GARREAU Pilot
 Extra 300 LT FHUSE
 A/C

Chateauroux Villers		Form B
Pilot ID	France Advanced connu-libre	
	Flight #	

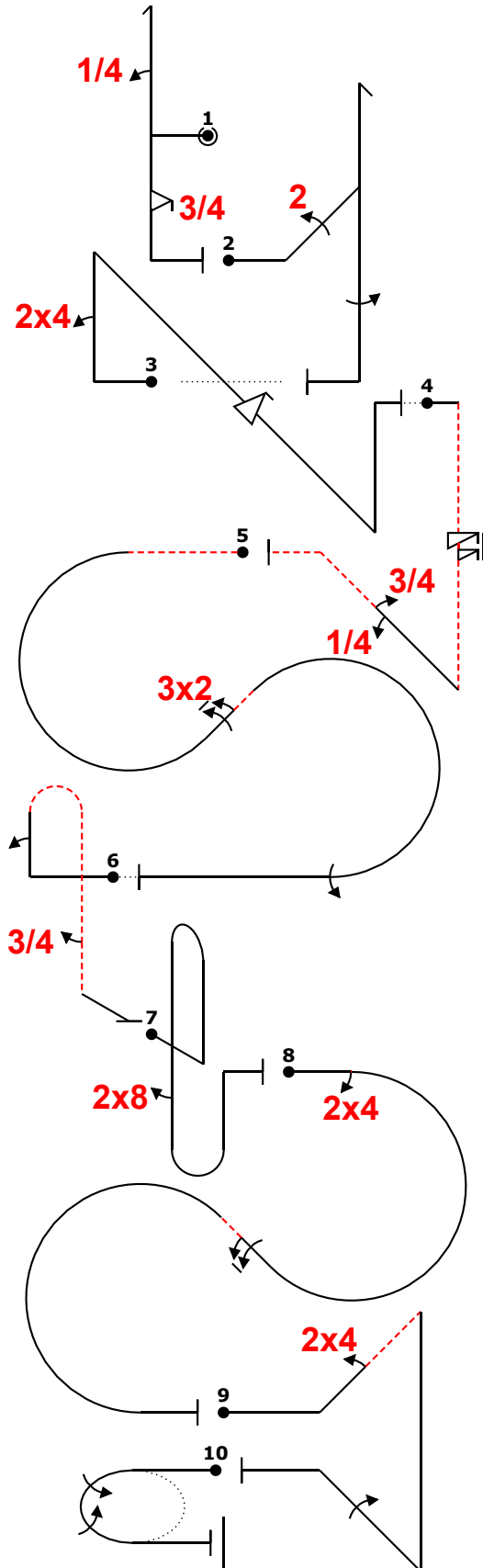
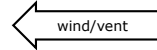

Power			
Fig	Aresti	K	
1 A	5.2.1.1	17	34
	9.1.1.1	6	
	9.9.5.3	11	
2	5.3.1.1	18	37
	9.2.2.4	11	
	9.1.5.4	8	
3	1.3.13.1	22	42
	9.4.1.2	9	
	9.9.4.4	11	
4 B	1.2.8.3	15	30
	9.11.1.6	3	
	9.1.2.1	4	
	9.1.2.3	8	
5	7.5.2.4	15	37
	9.2.2.6	14	
	9.1.3.4	8	
6 D	8.4.3.1	15	29
	9.1.1.2	8	
	9.1.5.3	6	
7	8.8.2.1	19	22
	9.8.5.1	3	
8 C	7.5.5.3	15	32
	9.4.3.2	5	
	9.1.2.6	12	
9 E	1.3.2.1	18	35
	9.4.2.2	7	
	9.1.2.4	10	
10	2.2.5.1	22	22
Total K = 320 (max K = 320)			

Chateauroux Villers		Form C
Pilot ID	France Advanced connu-libre	Flight #

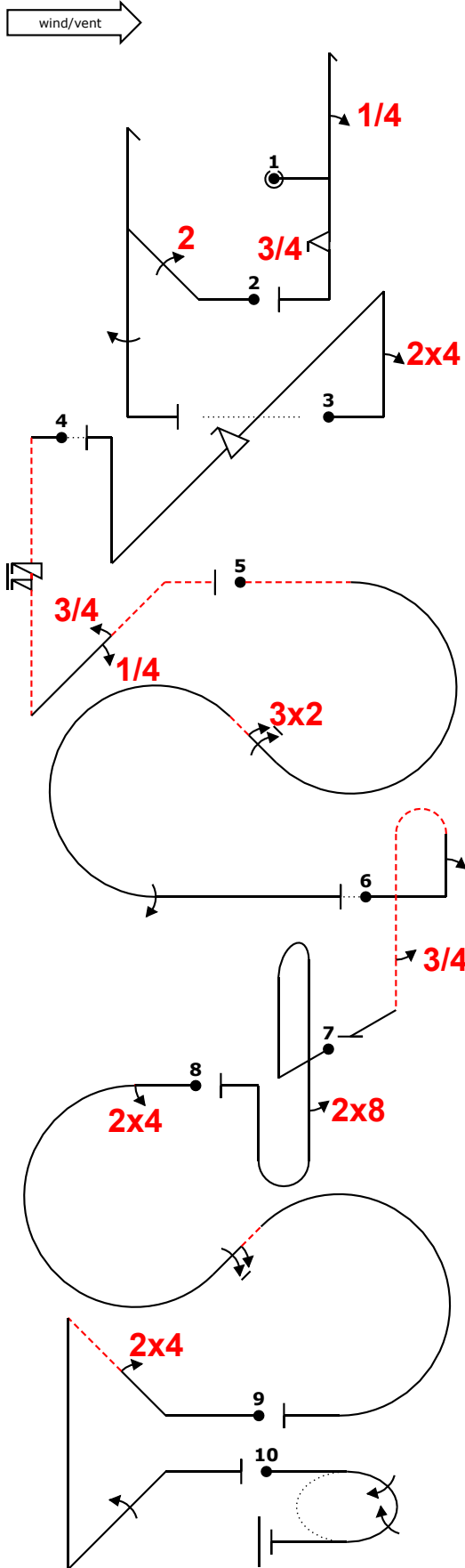

Power			
Fig	Aresti	K	
1 A	5.2.1.1	17	34
	9.1.1.1	6	
	9.9.5.3	11	
2	5.3.1.1	18	37
	9.2.2.4	11	
	9.1.5.4	8	
3	1.3.13.1	22	42
	9.4.1.2	9	
	9.9.4.4	11	
4 B	1.2.8.3	15	30
	9.11.1.6	3	
	9.1.2.1	4	
	9.1.2.3	8	
5	7.5.2.4	15	37
	9.2.2.6	14	
	9.1.3.4	8	
6 D	8.4.3.1	15	29
	9.1.1.2	8	
	9.1.5.3	6	
7	8.8.2.1	19	22
	9.8.5.1	3	
8 C	7.5.5.3	15	32
	9.4.3.2	5	
	9.1.2.6	12	
9 E	1.3.2.1	18	35
	9.4.2.2	7	
	9.1.2.4	10	
10	2.2.5.1	22	22
Total K = 320 (max K = 320)			

Vincent ANDRE Pilot
 Extra 330 SC F-HODY A/C